

Permit # 31278
RECEIVED

MAR 25 2010

BUREAU OF WATER

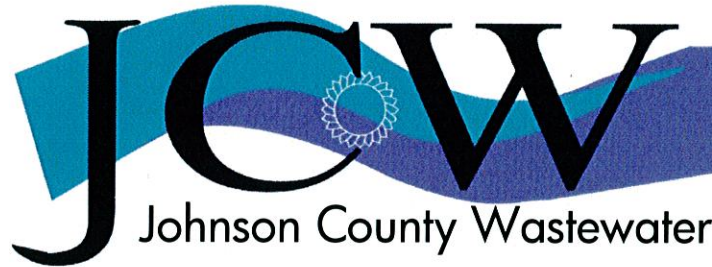

**STATE OF KANSAS
APPROVED
DIVISION OF ENVIRONMENT**

MAR 25 2010

[Signature]
**ENGR
TOPEKA, KANSAS**

Construction and Material Specifications for Sanitary Sewers

Approved on February, 24, 2010

Approved By:
State of Kansas Department of Health & Environment

Engineer

Date

Approved By:
Johnson County Wastewater

[Signature]

John Metzler, PE
JCW Chief Engineer

March 22, 2010

Date

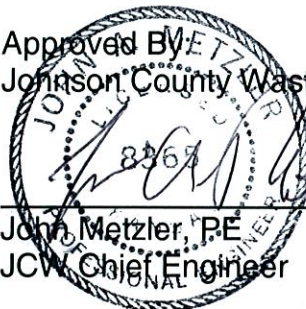

TABLE OF CONTENTS

SECTION 10 - REVISION LOG	10-1
SECTION 1000 - GENERAL REQUIREMENTS.....	1000-1
SECTION 1310 - PROJECT SURFACE VIDEO RECORDING	1310-1
SECTION 1400 - PROJECT INTERNAL TELEVISION INSPECTION.....	1400-1
SECTION 2230 - SITE PREPARATION AND EXCAVATION.....	2230-1
SECTION 2315 - TRENCHING AND BACKFILLING.....	2315-1
SECTION 2410 - TUNNELING	2410-1
SECTION 2445 - BORING	2445-1
SECTION 2530 - MANHOLES AND SPECIAL STRUCTURES.....	2530-1
SECTION 2531 - JCW MANHOLE RING AND COVER DETAILS	2531-1
SECTION 2532 - MANHOLE AND STRUCTURE INTERIOR COATINGS	2532-1
SECTION 2534 - SANITARY SEWER PIPE	2534-1
SECTION 2536 - SEWER PIPE INSTALLATION.....	2536-1
SECTION 2537 - CURED-IN-PLACE PIPE (CIPP)	2537-1
SECTION 2538 - PIPE BURSTING/REAMING	2538-1
SECTION 2539 - TESTING LABORATORY SERVICES.....	2539-1
SECTION 2920 - RESTORATION	2920-1
SECTION 2930 - NATIVE SEEDING AND RESTORATION PLANTINGS	2930-1
SECTION 2956 - SLOPE AND STREAM BANK/BED STABILIZATION	2956-1
SECTION 3000 - CAST-IN-PLACE CONCRETE	3000-1
SECTION 6650 - PLASTIC LINER FOR PROTECTION OF CONCRETE.....	6650-1

SECTION 1000 - GENERAL REQUIREMENTS

(Section 1000 is for use on Privately Financed Gravity Sewer Main Extension projects)

PART 1 GENERAL

1.01. DEFINITIONS

- A. Owner: Owner means the individual or entity with whom the Contractor has entered in an agreement to perform the Work.
- B. Johnson County Wastewater (JCW): JCW means the wastewater authority that governs the design, acceptance, operation, and maintenance of sanitary sewers, pump stations, and wastewater treatment facilities, constructed within the Consolidated Main Sewer District boundaries. JCW shall mean the Board of County Commissioners of Johnson County, Kansas, and their authorized agents.

1.02. WORK INCLUDED IN THIS SECTION

This Section governs general requirements for Privately Financed Gravity Sewer Main Extension projects.

1.03. SPECIFICATION MODIFICATIONS

It is understood that throughout these Specifications, modifications may be made by appropriate items in the Modifications to Detailed Specifications or notes on the Contract Drawings.

1.04. REVISIONS OF STANDARDS

When reference is made to a Standard Specification i.e. ASTM, ANSI, AWWA, MCIB, the Specification referred to shall be understood to mean the latest revision of said specification as amended at the time of the Notice to Bidders, except as noted on the Drawings or in the Modifications to Detailed Specifications.

1.05. WORKING HOURS

Normal working hours shall be from 7:00 am to 6:00 pm for the days Monday through Friday. Requests to work on a Saturday shall be received no later than 12:00 pm the Thursday prior to the Saturday in question. No work shall be done on Sundays or legal holidays. However, emergency work may be done without prior approval.

1.06. SUBMITTALS

Prior to beginning construction activities that incorporate materials addressed by these specifications or as shown on the Drawings, one (1) set of approved shop drawings and certifications shall be provided to JCW for all materials furnished.

1.07. SEWAGE BYPASS PUMPING

- A. General: If required to complete the construction of the project, the Contractor shall provide bypass pumping system to prevent flooding upstream of the project or the spill of sewage from the existing collection system.

- B. Submittals: Submit a detailed bypass pumping plan with sufficient information to allow the Engineer to determine the acceptability of the pumping system, including the following:
1. Bypass pumping phasing plan with exhibits and descriptions for each phase, including a schedule for installation and maintenance of bypass pumping system, and staging areas for pumps
 2. Bypass pump sizes, capacity, number of each size to be onsite and power requirements
 3. Size, length, material, location, and method of installation for suction and discharge piping
 4. Standby power generator size and location
 5. Road crossing details, if necessary
 6. Method of noise control for each pump and/or generator
 7. Flow and head calculations including friction loss for the length and type of pipe and static head
 8. Bypass pump curve(s) showing pump operating range
 9. Daily operations of the pump(s) and the maintenance of the pump(s) during the non-working hours
 10. Calculation of available time between pump failure and flooding, backups, etc.
- C. Temporary Bypass Pumping System: All bypass pumping system materials shall be suitable for contact with domestic sanitary sewage. The bypass pumping system shall include the following components:
1. Bypass pump(s) with sufficient capacity to pump the peak daily flow rates
 2. Backup pump(s) on site to provide 100% redundancy; backup pumps shall be isolated from the primary system by a valve
 3. Bypass pumping control system
 4. Bypass pumping system failure alarm(s)
 5. Discharge piping with leak-free joints
- D. Temporary Pumps: Pumps utilized in the bypass pumping system shall be self-priming and non-clog type capable of passing a non-compressible four-inch (4") sphere, designed for pumping domestic sewage containing solids and stringy materials. Engine exhaust shall be invisible, without objectionable fumes, smoke, oil mist, or carbon particles.

- E. Noise Control: Bypass pumping system components shall not have excessive noise levels and shall be restricted to a maximum of seventy decibels (70 dB) at a distance of 50 feet. If pumping is required on a 24-hour basis, engines shall be equipped in a manner to keep noise to a minimum.
- F. Sewage Spills: Violations of any state or federal laws caused by sewage spills shall be the sole responsibility of the Contractor. Should any liquid or solid matter from the sewer collection system be spilled, discharged, leaked or otherwise deposited to the open environment as a result of the bypass operations, Contractor shall be responsible for all cleanup and disinfection of the affected area and all associated costs. The Contractor shall also be responsible for notifying the Owner, sewer system operating personnel, and appropriate regulatory agencies and performing all required cleanup operations at no additional cost to the Owner.
- G. Wet Weather Conditions: The Contractor shall not perform bypass pumping of sewage if rain events are eminent. JCW shall have the ultimate authority with respect to delaying bypass pumping and associated sewer work due to weather conditions. The Contractor shall comply with any decisions made by JCW which delay bypass pumping and associated sewer work due to weather with no additional cost to the Owner. If wet weather or peak sewage flows exceed the bypass pumping capacity, pumping shall be suspended and all sewage flow shall be returned to the existing or new sewer pipe.

1.08. CONTROL AND CONSTRUCTION STAKING

Competent survey personnel under the direct supervision of a Professional Land Surveyor licensed in the State of Kansas and paid for by the Contractor shall perform all detailed construction staking including the staking of control points required for construction of the work. Offset grade stakes shall be placed at 25 feet, 50 feet, 100 feet and every 100 feet thereafter from each manhole. A temporary benchmark shall be placed every 400 feet along the alignment. All work performed shall conform to the lines, grades, elevations, and any tolerances shown on the Drawings and with any tolerances which may be set forth in these specifications.

1.09. PERMITS

The Contractor shall obtain all permits necessary to complete the Work and pay all fees, bonds, insurance, inspections, etc. associated with such permits. Permits to be obtained include but are not limited to: burning permits; blasting/explosives permits; permits/agreements for crossings of roads, highways, and railroads; utility crossing permits/agreements; NPDES permits; land disturbance permits; building permits; business licenses; etc. Contractor shall furnish copies of all permits to the Owner.

1.10. OBSERVATION OF THE WORK

A. General:

- 1. All materials and workmanship shall be subject to observation and examination by JCW at any and all times during construction and at any and all places where such construction is carried on. JCW shall have the authority to reject defective material and workmanship or require its correction. Unacceptable workmanship shall be satisfactorily corrected.

Rejected material shall be promptly segregated and removed from the project area and replaced with material of the specified quality to the satisfaction of JCW and at no additional cost to the Owner. JCW will not accept the project until such defects have been remedied or rejected materials removed from the project area.

2. The Contractor shall have available on the work site at all times the following documents: one copy of the plans; a coversheet signed by the required regulatory authorities including JCW, Kansas Department of Health and Environment (KDHE), and municipalities; and JCW's Standard Specifications with modifications approved by JCW specifically for this project (herein referred to as "these specifications").
3. The Contractor shall give the work the constant attention necessary to facilitate the progress thereof and shall cooperate with JCW inspectors in every way possible. The Contractor shall designate and have on the work site at all times, as his agent, a competent superintendent capable of reading and thoroughly understanding the plans and these specifications, who shall receive instructions from JCW. The superintendent shall have full authority to execute the orders or directions of JCW without delay and to supply promptly such materials, tools, plant equipment, and labor as may be required. Such superintendent shall be furnished irrespective of the amount of work sublet.
4. The Contractor shall at all times employ sufficient labor and equipment for prosecuting the classes of work to full completion in the manner and time, as applicable, required by these specifications. All workmen shall have sufficient skill and experience to perform properly the work assigned to them. Workmen engaged in special work or skilled work shall have sufficient experience in such work and in the operation of the equipment required to perform all work properly and satisfactorily.
5. Any person employed by the Contractor or by any sub-contractor who, in the opinion of JCW, does not perform his work in a proper and skillful manner or is intemperate or disorderly shall, at the written request of JCW, be removed forthwith by the Contractor or sub-contractor employing such person, and shall not be employed again in any portion of the work without the approval of JCW.
6. Should the Contractor fail to remove such person or persons as required above, or fail to furnish suitable and sufficient personnel for the proper prosecution of the work, JCW may suspend the work by written notice until such order(s) is/are complied with.
7. The Contractor shall furnish promptly all equipment, materials, and labor reasonably necessary for any tests which may be required.
8. Neither observing, testing, approval nor acceptance of the work in whole or in part, by JCW or its agents shall relieve the Contractor or his sureties of full responsibility for materials furnished or work performed not in strict accordance with these specifications.

9. Any change or deviation from the approved plans and these specifications that have been approved by JCW and KDHE must be received by the construction observer in writing prior to implementing the change. The construction observers are not authorized to alter any provisions or to issue instructions contrary to these specifications, or to make any revisions to any previously approved drawing.

B. Defective Work:

1. The term "defective" is used in these documents to describe work that is unsatisfactory, faulty, or deficient in that it does not conform to the requirements of these specifications, or not meeting the requirements of any observation, reference standard, test, approval, or acceptance required by law or these specifications.
2. Any defective work may be disapproved or rejected by JCW at any time before final acceptance even though it may have been previously overlooked.
3. Contractor shall perform all tests of questionable equipment or materials from completed work for testing purposes when required by JCW.

C. Uncovering Work:

1. If any work is covered without concurrence of the construction observer it must, if requested by the construction observer, be uncovered for observation.
2. Should it be considered necessary or advisable by JCW, at any time before final acceptance of the entire work to make an examination of work already completed by uncovering the same, the Contractor shall on request promptly furnish all necessary facilities, labor, and material.

1.11. MAINTENANCE OF TRAFFIC

All trenching, excavation and other construction work shall be made in a manner to cause the least interruption to traffic. Where permits are required of the Contractor to excavate or obstruct public property, he shall in all ways comply with the provisions or requirements of the proper authorities issuing such permits including, but not limited to, the development of a traffic control plan and the authorities' requirements as to time, notice required, warning devices and temporary structures required.

1.12. MAINTENANCE OF EXISTING PUBLIC INFRASTRUCTURE OR PRIVATE PROPERTY

Wherever the work is in the vicinity of existing public infrastructure or private property, the Contractor shall use utmost care not to damage or destroy any existing infrastructure or property. Any infrastructure or property damaged or destroyed due to the operations of the Contractor shall be paid for or replaced to the satisfaction of the owner of such property. The Contractor shall be held responsible for all damage to roads, highways, shoulders, ditches, bridges, culverts, sidewalks, signs, and other property caused by him or his sub-contractors in transporting materials to or from the site of work, regardless of

the location of such damage, and shall such damaged property to the satisfaction of the owner of such property.

1.13. PUBLIC NOTIFICATION

A public notification program shall be implemented and shall, as a minimum, require the Contractor to be responsible for contacting each property owner and resident of the property to inform them of the work to be conducted on their property. The Contractor shall provide written notice to be delivered to each property owner and resident of the property three (3) days prior to the beginning of work being conducted, and a local telephone number of the Contractor that the owner or resident can call to discuss the project or any potential problems. The office number of the appropriately identified JCW representative shall also be included on this notice.

1.14. BARRICADES AND LIGHTS

The Contractor shall erect and maintain such barricades, construction signs, torches, red lanterns and guards as may be required to protect persons from injury and to avoid property damage during the construction period and until it is safe for traffic to use the facilities. Rules and regulations of the local authorities respecting safety provisions shall be observed. All excavated material shall be piled in a manner that will not endanger the work and that will avoid obstructing sidewalks or driveways. Gutter shall be kept clear or other satisfactory provisions made for street drainage. All construction signs and traffic controls shall be in accordance with the "Manual on Uniform Traffic Control Devices" (DOT-FHWA).

1.15. SITE SAFETY

The Contractor shall maintain and enforce all safety precautions required by the Occupational Safety and Health Act (OSHA), federal and state standards and requirements pertaining to all aspects of the work. Particular attention is drawn to those safety requirements involving work on an elevated platform, rules 29 CFR Part 1926, Subpart P regarding excavations and trenches, and 29 CFR 1910.146 regarding confined spaces.

1.16. SITE MAINTENANCE

The Contractor shall not allow the site of the work to become littered with trash and waste material but shall maintain same in a neat and orderly condition during the process of the work to completion. The Contractor shall clean up all dirt from paved surfaces, not allow same to pack on the roadway or create a traffic nuisance.

1.17. TEMPORARY UTILITIES

All temporary utilities (water, electricity, etc.) used for proper completion of the work shall be furnished by the Contractor. The Contractor shall meter and pay all utility costs for the temporary utilities used.

1.18. UNFAVORABLE CONSTRUCTION CONDITIONS

During unfavorable weather, or other unfavorable conditions for construction operations, the Contractor shall pursue only such portions of the work as will not be damaged thereby.

1.19. CONNECTIONS TO EXISTING FACILITIES

The Contractor shall make all necessary connections to existing structures, sewers, and utility lines as detailed in the Drawings. Thoroughly plan such connections in advance and perform such connections as expeditiously as possible.

PART 2 PRODUCTS

PART 3 EXECUTION

END OF SECTION 1000

SECTION 1310 - PROJECT SURFACE VIDEO RECORDING

PART 1 GENERAL

1.01. WORK INCLUDED IN THIS SECTION

This Section governs creating of high quality project video recording of surface conditions prior to the beginning of construction. If required by the Drawings or by other specifications, Contractor will provide the JCW with a high quality project video recording.

1.02. SPECIFICATION MODIFICATIONS

It is understood that throughout this section these Specifications may be modified by appropriate items in the Modifications to Detailed Specifications or notes on the Contract Drawings.

1.03. REVISIONS OF STANDARDS

When reference is made to a Standard Specification i.e. ASTM, ANSI, AWWA, MCIB, the Specification referred to shall be understood to mean the latest revision of said specification as amended at the time of the Notice to Bidders, except as noted on the Drawings or in the Modifications to Detailed Specifications.

1.04. SUBMITTALS

The Contractor shall provide certifications or shop drawings on all materials provided under these specifications in accordance with the General Requirements.

1.05. QUALITY ASSURANCE:

The project videoing shall be performed by a qualified commercial company or individual who is experienced with video equipment and video recording of pre-construction surface conditions.

PART 2 PRODUCTS

PART 3 EXECUTION

3.01. PROJECT VIDEO RECORDING

A high quality project video recording of existing surface conditions shall be created and updated by the Contractor prior to beginning construction and at critical times during the construction process. The following locational information shall be provided on color audio-video recordings:

- A. Audio: Each recording shall begin with a verbal description of the current date, project name and municipality and be followed by the general location, i.e. name of the street, viewing side and direction of progress.
- B. Video: Transparent information must appear on the viewing screen. This information will consist of the date and time of recording. The date information will contain the month, day and year.

- C. Digital: To preclude the possibility of tampering or editing in any manner, all video recordings must, by electronic means, display continuously and simultaneously generated transparent digital information to include the date and time of recording. The date information will contain the month, day and year.
- D. The video coverage shall include all surface features located within the zone of influence of construction supported by appropriate audio description. Audio description shall be made simultaneously with video coverage. Such coverages shall include, but not be limited to, all existing driveways, sidewalks, fences, curbs, ditches, roadways, landscaping, trees, culverts, headwalls, retaining walls, or buildings located within such zones of influence. Particular and detailed attention shall be given to any defects noted, such as cracks, disturbed areas, damaged items, or as may be required by JCW. It is the intent of this coverage to accurately and clearly document pre-existing, post-construction or construction conditions and especially any items that could result in construction claims. Any excavation areas shall be physically marked with high visibility flags prior to video recordings.
- E. The zone of influence shall be defined as an area within the temporary construction easement as indicated on the plans or within 35 feet of the proposed work, and an additional 20 feet of supplemental coverage shall be provided in residential areas.
- F. The Contractor shall obtain permission from the property owner prior to entering private property for the purpose of video recording.
- G. To produce the proper detail and perspective, adequate lighting will be required to fill in the shadow area caused by trees, utility poles, road signs and other such objects in residential areas or as directed by JCW.
- H. Houses and buildings shall be identified visually by house number, when visible, in such a manner that structures of the proposed system, i.e. manholes on a sewer system, can be located by reference.
- I. The rate of speed in the general direction of travel of the conveyance used during taping shall not exceed 48 feet per minute in residential areas, nor exceed 100 feet per minute in non-residential areas. Panning rates and zoom-in and zoom-out rates shall be controlled sufficiently such that during playback picture shall be in focus and shall maintain clarity at all times.
- J. All recording shall be done during times of good visibility. No recording shall be done during periods of visible precipitation, or when more than 10% of the ground area is covered with snow, unless otherwise authorized by JCW.
- K. JCW shall have the authority to designate what areas may be omitted or added for audio-video coverage.
- L. All CD's or DVD's (and cases) shall be properly identified by CD number, location, project name and municipality in a manner acceptable to JCW.
- M. A record of the contents of each video shall be supplied by a run sheet identifying each segment in the video by location, i.e., roll number, street or road viewing,

tape counter number, viewing slide, point starting from, traveling direction and ending destination point.

- N. Conventional wheeled vehicles cannot be used.
- O. All video shall be CD or DVD format with a file path (.wmv).
- P. Any portion of the video recording not conforming to specifications shall be rejected.
- Q. If the recording is performed by a sub-contractor, a project representative of the Contractor shall be present during the video recording unless otherwise approved by JCW. All video recording shall be reviewed by the Contractor for quality and completeness prior to submittal to JCW. JCW must also be notified 3 days prior to recording so that owner may be present during recording.
- R. Any recorded coverage not acceptable to JCW shall be refilmed at no additional charge. The Contractor shall reschedule unacceptable coverage five (5) days after being notified.
- S. One original and two copies are to be provided. Original to JCW, one copy to the Owner, and one copy to the Contractor.
- T. Compensation for record videos shall be subsidiary to other contract items.

END OF SECTION 1310

SECTION 1400 - PROJECT INTERNAL TELEVISION INSPECTION

PART 1 GENERAL

1.01. WORK INCLUDED IN THIS SECTION

This Section governs closed circuit televising and concurrent video recording of the existing sewer line segments. If required by the Drawings or by other specifications, the Contractor will provide JCW with a high quality internal color video recording showing both the pre- and post-construction conditions, including the restored connections.

1.02. SPECIFICATION MODIFICATIONS

It is understood that throughout this section these Specifications may be modified by appropriate items in the Modifications to Detailed Specifications or notes on the Contract Drawings.

1.03. REVISIONS OF STANDARDS

When reference is made to a Standard Specification i.e. ASTM, ANSI, AWWA, MCIB, the Specification referred to shall be understood to mean the latest revision of said specification as amended at the time of the Notice to Bidders, except as noted on the Drawings or in the Modifications to Detailed Specifications.

1.04. SUBMITTALS

The Contractor shall provide certifications or shop drawings on all materials provided under these specifications in accordance with the General Requirements.

1.05. QUALITY ASSURANCE:

The project internal video shall be performed by a qualified commercial or individual company who is familiar with television inspection equipment & is PACP (Pipeline Assessment Certification Program) certified by NASSCO (National Association of Sewer Service Companies).

PART 2 PRODUCTS

PART 3 EXECUTION

3.01. **PROJECT VIDEO RECORDING:** A high quality project video recording of existing internal conditions shall be created and updated by the Contractor prior to beginning construction and after construction is complete. The following locational information shall be provided on color audio-video tape recordings: The pre- and post-construction videos shall conform with PACP standards.

A. Audio: Each recording shall begin with a verbal description of the current date, project name and municipality and be followed by the site number, general location, i.e. project street address, upstream and downstream manhole and direction of progress. Audio should also include location of all pipe defects and conditions, and service connections with addresses. The project location shall be the location of the upstream manhole.

- B. Video: Transparent information must appear on the viewing screen at all times. This information shall contain the site number, upstream manhole number, downstream manhole number, month, day, year, and continuous footage. All pipe conditions, service connections with addresses shall be noted at the appropriate locations.
- C. All video, including cases, shall be properly identified by video number, location, project name and municipality in a manner acceptable to JCW.
- D. Any portion of the video recording not conforming to specifications shall be rejected.
- E. All video shall be provided to JCW in CD format & operable using Windows Media Player and also must have file path (.WMV).
- F. Allowable Flow Depth: When depth of flow in the upstream manhole of the line segment being inspected is above the maximum allowable level for television inspection, the flow shall be reduced. The depth of flow shall not exceed the levels shown below for the respective pipe sizes, as measured in the manhole at the time of inspection:

Pipe Dia. (inches)	Max Flow Depth (% of Dia.)
≤ 10	20
12 - 24	25
≥ 27	30

3.02. TELEVISION INSPECTION EQUIPMENT:

- A. Camera: A pan and tilt camera shall be used on pre- and post-construction televising of all line segments. The camera shall be used to pan and view service connections before and after segment has been lined. Camera speed shall not exceed 30 feet per minute.
- B. Lighting: Lighting for the camera shall be suitable to allow a clear picture of the entire periphery of the pipe. The camera shall be operative in 100% humidity conditions. The camera and other components of the video system shall produce a color picture quality to the reasonable satisfaction of the Owner; and if unsatisfactory, the equipment shall be replaced with equipment producing satisfactory quality.

3.03. INSPECTION LOG

An inspection log which is PACP certified shall be kept by the Contractor to document all defects and service connections found during television inspection. This log sheet will identify the project number, owner name, street address, site number, upstream and downstream manhole numbers, date, time, location of defects and conditions, service connections with addresses, and any other relevant data. These log sheets will be presented along with the video to the Owner prior to the inversion of liner. This PACP inspection log will be provided in such a manner as to be downloadable into GBA Master Series Software (GBA MS).

3.04. QUALITY

Any video recording not acceptable to JCW shall be refilmed (start to finish) at no additional charge to the Owner. The Contractor shall reschedule unacceptable coverage five (5) days after being notified.

3.05. QUANTITY

One original video log sheet & CD are to be provided to JCW.

END OF SECTION 1400

SECTION 2230 - SITE PREPARATION AND EXCAVATION

PART 1 GENERAL

1.01. WORK INCLUDED IN THIS SECTION

This Section governs project site preparation for construction and the methods and procedures required for pipeline excavations for open cut and tunneling. Additional requirements for tunneling and other trenchless methods are covered in other sections.

1.02. SPECIFICATION MODIFICATIONS

It is understood that throughout this section these Specifications may be modified by appropriate items in the Modifications to Detailed Specifications or notes on the Contract Drawings.

1.03. REVISIONS OF STANDARDS

When reference is made to a Standard Specification i.e. ASTM, ANSI, AWWA, MCIB, the Specification referred to shall be understood to mean the latest revision of said specification as amended at the time of the Notice to Bidders, except as noted on the Drawings or in the Modifications to Detailed Specifications.

1.04. SUBMITTALS

The Contractor shall provide certifications or shop drawings on all materials provided under these specifications in accordance with the General Requirements.

PART 2 MATERIALS

2.01. GRANULAR FILL

Granular fill material shall be crushed rock or gravel fill and shall be free from dust, clay, and trash; hard, durable, non-friable; and shall be per the requirements of paragraph 2.01 of SECTION 2536 - SEWER PIPE INSTALLATION. Only crushed rock with angular particles shall be used when the perimeter of the granular fill is not confined or otherwise subject to raveling, such as on a slope.

PART 3 EXECUTION

3.01. GENERAL

- A. Contractor shall do all clearing necessary for performance of his work and shall confine his operations to that area provided through easements, licenses, agreements and rights-of-way. The Contractor's entrance upon any lands outside of that area provided by easements, licenses, agreements or public rights-of-way, shall be at the Contractor's sole liability. The limits of construction are as indicated on the Drawings.
- B. The Contractor shall not occupy any portion of the Project Site prior to the date established in the Notice to Proceed without prior approval of the Engineer.

- C. The top soil shall be removed and stockpiled in accordance with paragraph 2.01 of SECTION 2920 - RESTORATION.
- D. Where the top of the proposed main is three (3) feet or less from the existing ground surface, compacted fill must be placed to a minimum height of three (3) feet above the top of the proposed sewer main prior to the installation of the main. Three (3) feet of cover shall be provided at all times over the sanitary sewer main.
- E. Temporary Erosion Control:
 - 1. Provide temporary erosion and sedimentation control measures to prevent soil erosion and discharge of soil-bearing water runoff or airborne dust to adjacent properties and walkways, according to a sediment and erosion control plan, specific to the site, that complies with EPA 832/R-92-005 or requirements of the Drawings, the Modifications to Detailed Specifications, or the authorities having jurisdiction, whichever is more stringent.
 - 2. Inspect, repair, and maintain erosion and sedimentation control measures during construction until permanent vegetation has been established.
 - 3. Remove erosion and sedimentation controls and restore and stabilize areas disturbed during removal.
 - 4. All costs associated with the erosion control devices shall be included in the Contractor's bid prices for other components of the work.

3.02. OBSTRUCTIONS

- A. General: Natural obstructions and existing facilities and improvements encountered during site preparation shall be removed, relocated, reconstructed, or worked around as herein specified and as directed by the Engineer. Care shall be used while performing site preparation work adjacent to any facilities intended to remain in place. Except as otherwise specified, the Contractor shall be responsible for any damage to existing facilities and improvements and any repairs required shall be promptly made at the Contractor's expense. All repairs by the Contractor shall be to the existing or better condition prior to construction. Waste materials shall be disposed of in a satisfactory manner off the work site at a disposal area arranged by the Contractor. Unless otherwise provided in Basis of Payment, no separate or additional payment will be made for any work in connection with removal, relocation or restoration of obstructions and existing facilities.
- B. Surface Obstructions:
 - 1. General: Sidewalks, curb and gutter, drainage structures and similar obstructions shall be tunneled under if tunneling is best suited, otherwise the obstruction shall be cut in straight lines or removed to the nearest construction joint if located within five feet of the edge of the trench. In no case shall the joint or line of cut be less than one foot outside the edge of the trench. Surface obstructions removed to permit construction shall be

reconstructed as specified and to the dimensions, lines and grades of original construction. Backfill of tunneled sections shall be performed in accordance with SECTION 2315 - TRENCHING AND BACKFILLING. Unless noted otherwise on the Drawings, all restoration shall be in accordance with SECTION 2920 - RESTORATION and in accordance with the requirements of the city having jurisdiction. Restoration of utilities damaged by the Contractor shall be restored as required by the owner of the utility at no additional cost to the Owner.

2. Residential Driveways: If residential driveways are allowed to be crossed by the open cut method, the Contractor shall saw cut driveways to remove all damaged edges and all undermined and heaved pavement. Saw cuts shall be made perpendicular to the existing driveway edge. If there is an existing joint within 10 feet of the proposed saw cut, then the driveway shall be replaced to the existing joint. However, in no case shall the distance between the saw cuts be less than 15 feet. Restoration of the driveway shall be in accordance with SECTION 2920 - RESTORATION and in accordance with the requirements of the city having jurisdiction.
3. Mailboxes: Mailboxes shall be maintained in the manner that the Postal Service requires to prevent interruption of mail delivery.
4. Vegetation: Site preparation shall include, where necessary, the removal of trees, shrubs, brush, crops, and other vegetation within the limits of the easements (right-of-way) as indicated on the Drawings, or as may be provided for in licenses, permits and agreements. The following procedures for protection of existing greenery are required:
 - a. Trees: A reasonable effort shall be made to save as many trees as possible. If trees can be saved by pruning, this shall be done in accordance with acceptable pruning practices. Trees shown on the Drawings to be saved shall not be removed or damaged and may require tunneling, trench shoring, or other means to avoid damage. Trees to be saved are indicated as such with an "S" labeled on the symbol denoting tree location. Other trees shown on the plan sheets within construction limits as defined by temporary easements may be removed, and no replacement is required.
 - b. Large trees allowed to be removed shall be completely removed, including stump and large roots, unless such removal may result in damage to existing pipelines. In that event, large trees shall be sawed off not more than four (4) inches above the ground and then the stump shall be removed to twelve (12) inches below finish grade.
 - c. Protection of Trees: At all trees shown on the plan sheets to be saved, a temporary barricade shall be constructed around the tree at the tree's approximate drip line. The barricade shall be at least 3 feet high, consisting of 2 inch by 4 inch (or larger) posts set at least 18 inches into the ground at not more than 6 feet on centers,

joined at the top by 1 inch by 6 inch (or larger) boards firmly nailed to the posts. Special care shall be taken in setting posts to prevent damage to tree roots. Stockpiling of materials or debris within the barricaded area is prohibited, and the earth surface in these areas shall not be disturbed in any way except as specifically approved by the Engineer.

- d. Small Plants and Flowers: At least two weeks prior to the start of construction, property owners shall be notified by the Contractor of the proposed starting date. The purpose of this notification is so that the property owners can remove any small plants or flowers that they, the property owners, desire to save.
 5. Sodded and Landscaped Areas: Sodded and/or landscaped thoroughfares and areas on or adjacent to improved property shall be disturbed only to the extent required to permit construction. Such areas shall not be used as storage sites for construction supplies and insofar as practicable, shall be kept free from stockpiles or excavated materials.
 6. Fences: Fences interfering with construction, and located within public rights-of-way or as may be allowed for in permits or agreements, may be removed by the Contractor, only if the opening is provided with a temporary gate which will be maintained in a closed position except to permit passage of equipment and vehicles, unless otherwise herein specified. Fences within temporary construction easements may be removed by the Contractor provided that temporary fencing is installed in such a manner as to serve the purpose of the fencing removed. The Contractor shall locate and record all fence corners prior to removal. All fencing removed shall be restored by the Contractor to the existing or better condition prior to construction unless otherwise specified in the Modifications to Detailed Specifications. The Contractor is and shall be solely liable for the straying of any animals protected or corralled or other damage caused by any fence so removed.
- C. Subsurface Obstruction:
1. General: The Contractor shall make a reasonable effort to ascertain the existence of underground obstructions and shall locate such obstructions by digging in advance of machine excavation where definite information is not available as to their exact location. Where such facilities are unexpectedly encountered and damaged, responsible officials and other affected parties shall be notified and arrangements made for the prompt repair and restoration of service.
 2. Utilities: Where existing utilities and service lines are to be encountered, the utility owner thereof shall be notified by the Contractor at least 48 hours (not including weekends and/or holidays) in advance of performing any work in the vicinity. All excavation, pipeline installation and backfilling work in the vicinity of such utilities shall be accomplished in the manner required by the respective utility owner and, if requested, under his direct supervision. The Contractor shall be responsible for any and all damages

to a public or private utility that may occur as the result of the construction.

3. Private Sewer Facilities: The Contractor shall make every reasonable effort to protect private sewer facilities. When these facilities are disturbed or damaged by the work, the Contractor shall make necessary repairs to the facilities for continuous service prior to the close of the work day at no cost to the Owner. All repairs shall be inspected and approved by the jurisdictional authority.
4. Property Pins: The Contractor shall preserve all property corners, pins or markers. In the event any property corners, pins, or markers are removed by the Contractor, such property points shall be replaced at the Contractor's expense and shall be reset by competent surveyors properly licensed to do such work. In the event such points are section corners or Federal land corners, they shall be referenced and filed with the appropriate authority.
5. Sprinkler Systems: Sprinkler systems removed or damaged during the performance of work shall be repaired or replaced. The disturbed portion of the sprinkler system shall be capped so that the remainder of the system may be operated during the construction period.

3.03. EXCAVATION

A. General

1. All pipeline excavation work shall be accomplished under supervision of a person experienced with the materials and procedures which will provide protection to existing improvements, including utilities and the proposed pipeline.
2. The alignment, depth, and pipe subgrade of all sewer trenches shall be determined by a laser beam parallel to the sewer invert.
3. The Contractor shall not open more trench in advance of pipe laying than is necessary. Four hundred (400) feet will be the maximum length of open trench allowed on any line under construction unless otherwise approved by the Engineer. All open trenches shall be adequately protected.
4. In the event hazardous wastes as defined by the Resource Conservation and Recovery Act of 1976 (PL94-580) are encountered, work shall be halted and the Engineer and JCW shall be notified. Work shall be resumed only after JCW notifies the Contractor. Regulation of removal, handling and disposal of hazardous wastes is the responsibility of Federal and State agencies.

- B. Unclassified Excavation: Unclassified excavation is defined as the removal of all material encountered regardless of its nature. All material excavated will be considered as Unclassified Excavation unless the Modifications to Detailed Specifications specify Classified Materials.

C. Dewatering:

1. The Contractor shall remove any water which may accumulate or be found in the trenches and other excavations made under the Contract. The Contractor shall form all dams, flumes or other works necessary to keep the excavation clear of water while the sewers and their foundations, and other foundation works, are being constructed. Water shall not be permitted to enter any installed sanitary sewer. All water shall be removed from such excavation in a manner so as not to create unsanitary conditions, nor to cause injury to persons or damage to the work in progress or to the subgrade or to other property, either private or public, nor to interfere unduly with the use of streets, alleys, or of private drives and entrances. The Contractor shall employ Best Management Practices to limit the discharge of sediment to the stream.
2. Dewatering equipment shall be provided to remove and dispose of all surface water and groundwater entering excavations, trenches, or other parts of the work. Each excavation shall be kept dry during subgrade preparation and continually thereafter until the structure to be built, or the pipe to be installed therein, is completed to the extent that no damage from hydrostatic pressure, flotation, or other cause will result.
3. All excavations for concrete structures or trenches which extend down to or below groundwater shall be dewatered by lowering and keeping the groundwater level at least 12 inches beneath such excavations. The specified dewatering depth shall be maintained below the prevailing bottom of excavation at all times.
4. Surface water shall be diverted or otherwise prevented from entering excavations or trenches to the greatest extent possible without causing damage to adjacent property.
5. Contractor shall be responsible for the condition of any pipe or conduit which he may use for drainage purposes, and all such pipe or conduit shall be left clean and free of sediment.

D. Blasting

1. No Blasting Areas: No blasting of any kind for rock excavation or any other purpose will be allowed if so noted on the Drawings.
2. When blasting is permitted by the governing city or county and approved by the Engineer, the Contractor shall use the utmost care to protect life and property. The Contractor shall comply with all laws, ordinances, and the applicable safety code requirements and regulations relative to the handling, storage and use of explosives and protection of life and property, and he shall be responsible for all damage thereto caused by his or his subcontractor's operations. The Contractor shall obtain all necessary permits from the governing city or county and any other entity having jurisdiction at no extra cost to the Owner.

3. Contractor shall comply with the applicable requirements of the National Fire Protection Association (NFPA) 495 Explosive Material Code, the International Fire Code (IFC) Chapter 33, and the Occupational Safety & Health Administration Explosives and Blasting Agents 29 CFR Part 1910.109 for the storage and use of explosives, unless requirements herein or of any authority having jurisdiction are more restrictive, in which case the Contractor shall comply with the more restrictive requirements.
4. Contractor shall engage the services of a qualified blasting engineer to develop blasting procedures and assist in monitoring blasting operations.
5. Pre-blast Survey. Contractor shall perform a pre-blast survey of all utilities, structures, and other facilities adjacent to the blast sites to determine the conditions of each utility, house, building, bridge, overpass, and other structures and facilities susceptible to damage from blasting operations. The pre-blast survey shall include all structures and utilities within a minimum of a 500-foot radius of the area to be blasted, unless a greater radius is required by the authority having jurisdiction, in which case the greater radius shall govern. The survey notification to all property owners, tenants, utilities, and other agencies and the area of survey shall be in conformity with the requirements of the authority having jurisdiction thereover or as determined by Contractor's insurance company if no local ordinance applies. Contractor shall submit the pre-blast survey report to Owner for record purposes.
6. Notification. Contractor shall notify in writing through the U.S. Mail all affected adjacent property occupants within 1,500 feet at least 24 hours prior to any blasting. Contractor shall be responsible for all damage caused by blasting operations and shall be responsible for responding to and resolving all complaints. Suitable methods shall be employed to confine all materials lifted by blasting within the limits of the excavation or trench.
7. All rock which cannot be handled, crushed, processed, and compacted as earth shall be kept separate from other excavated materials and shall not be mixed with backfill or embankment materials except as specified or directed.
8. Blasting or other use of explosives for excavation adjacent to existing utilities, structures, and other facilities shall be in conformity with the requirements of the local ordinance and the authority having jurisdiction thereover and shall not cause damage to any adjacent structures. Contractor shall consult with and obtain written approval for blasting procedures from the appropriate utility or agency before blasting adjacent to their utilities, structures, or other facilities. Certain utilities, including gas pipelines and fiber optics, and agencies have requirements that will not permit blasting adjacent to or within a minimum distance from their utilities or structures, including utilities and structures outside the construction easements or on the opposite side of the street, if applicable. The blasting procedures shall be in conformity with the requirements of

the utility, if applicable. Contractor shall submit to Owner a copy for the record of the blasting procedures sealed by the blasting engineer.

9. Contractor shall be responsible for obtaining all required blasting permits from the city, county, state and federal agencies and shall provide sufficient prior notice as specified by code, ordinance or other regulation to the county engineer, county sheriff, fire districts, police departments, and all other appropriate agencies and authorities where the blasting is to be performed. A copy of the blasting permit shall be on the site before and during the blasting operations. Owner shall be furnished a copy of all blasting permits at least 7 days prior to blasting.
10. Suitable weighted plank coverings, mattresses, insitu overburden or backfill shall be provided by the Contractor to confine all materials, lifted by the blasting, within the limits of the trench or excavation.
11. The Contractor shall obtain insurance as required by the General Conditions and Supplementary Conditions and Modifications to Detailed Specifications before performing any blasting. The governing agency shall be notified at least 24 hours before blasting operations begin.
12. Blast Monitoring
 - a. Prior to the start of Contractor's blasting, Contractor shall measure background ground vibrations. Seismographs shall be placed on the ground adjacent to structures subjected to ground shock to measure peak particle velocity components in three mutually perpendicular directions during blasting operations.
 - b. The peak particle velocity, defined as the maximum of the three velocity components of vibration, at any location shall not exceed values that will cause damage to the adjacent structures. Air overpressure shall be measured at adjacent structures. Air overpressure at adjacent structures shall not exceed values that will cause damage to the adjacent structures or personnel. The maximum peak particle velocity and air overpressure values that will not cause damage shall be determined by the blasting engineer retained by Contractor and shall be stated in the blasting procedures.
 - c. Contractor shall submit measurement records of the blast monitoring within 24 hours after each blast for record purposes to Owner.
13. Post-blast Survey. Contractor shall perform a post-blast survey of the same utilities, structures, and other facilities surveyed in the pre-blast survey to determine the effect of the blasting operations. Contractor shall submit the post-blast survey report to Owner prior to Substantial Completion.

END OF SECTION 2230

SECTION 2315 - TRENCHING AND BACKFILLING

PART 1 GENERAL

1.01. WORK INCLUDED IN THIS SECTION

This section establishes the requirements to be followed for pipeline excavation performed by the open cut method (trenching) and governs the furnishing of all labor, equipment, tools and materials to properly backfill trenches and structures.

1.02. SPECIFICATION MODIFICATIONS

It is understood that throughout this section these Specifications may be modified by appropriate items in the Modifications to Detailed Specifications or notes on the Contract Drawings.

1.03. REVISIONS OF STANDARDS

When reference is made to a Standard Specification i.e. ASTM, ANSI, AWWA, MCIB, the Specification referred to shall be understood to mean the latest revision of said specification as amended at the time of the Notice to Bidders, except as noted on the Drawings or in the Modifications to Detailed Specifications.

1.04. SUBMITTALS

The Contractor shall provide certifications or shop drawings on all materials provided under these specifications in accordance with the General Requirements.

PART 2 PRODUCTS

2.01. BACKFILL MATERIALS

- A. Granular Embedment: Granular embedment shall meet the gradation requirements as outlined in SECTION 2536 - SEWER PIPE INSTALLATION.
- B. Select Earth Backfill: Select earth backfill shall be finely divided job excavated material free from debris, organic matter, rocks larger than one (1) inch and/or frozen materials.
- C. Standard Earth Backfill: Standard earth backfill shall be an earth and rock mixture free from debris and organic matter with sufficient earth to completely fill all voids between the rocks.
- D. Topsoil: Topsoil shall be as defined in paragraph 2.01 of SECTION 2920 - RESTORATION.
- E. Backfill of Street Cuts: The backfill materials above the pipe embedment and under pavement or unpaved areas within the Right-of-Way shall meet the requirements of the jurisdictional agency or the Drawings.
- F. Flowable Fill: Flowable fill used for backfill in areas other than in the Right-of-Way shall meet the requirements of 2.01.C of SECTION 3000 - CAST-IN-PLACE CONCRETE

G. Imported Fill Material:

1. Notification: For approval of imported fill material, notify the Engineer at least four (4) working days in advance of intention to import material, designate the proposed borrow area, and permit the Engineer to sample as necessary from the borrow area for the purpose of making acceptance tests, as specified in paragraph 2.01.G.4 below, to prove the quality of the material. The Contractor shall be responsible for all costs associated with proving the quality of the imported fill material.
2. Imported Impervious Structural Fill Material Requirements: All impervious structural fill material shall meet the requirements set forth in ASTM D2487 soil classification groups CL, CH, and ML or a combination of these group symbols; and shall be free of plant growth, roots, and humus. The particle size of impervious material shall be such that a minimum of 50 percent of soil particles shall pass a U.S. Standard No. 200 screen.
3. Imported Fill Material for pipeline construction shall be soil or soil-rock mixture that is free from organic matter and other deleterious substances; it shall contain no rocks or lumps more than 3 inches in greatest dimension; and not more than 15% of the rocks or lumps shall be larger than 2-1/2 inches in greatest dimension.
4. All tests required for preliminary review of materials shall be made by an acceptable independent testing laboratory at the expense of Contractor. Two initial gradation tests shall be made for each type of general fill, designated fill, backfill, or other material, and one additional gradation test shall be made for each additional 500 tons of each material delivered to the jobsite. In addition, one set of initial Atterberg Limits test shall be made for each fill material containing more than 20 percent by weight pass the No. 200 sieve and for materials specified by Atterberg Limits. One additional Atterberg Limits test shall be made for each additional 500 tons of each material delivered to the job site.

2.02. FILTER FABRIC

Filter fabric shall be provided in rolls wrapped with covering for protection from mud, dirt, dust, and debris. Standard filter fabric is used to keep one material separated from another material. Standard filter fabric shall be used to encapsulate the granular embedment material in fine sands and silts which could potentially move into the bedding and cause settlement. Filter materials to be used with the stream crossing restoration shall be per SECTION 2956 - SLOPE AND STREAM BANK/BED STABILIZATION.

- A. Standard Filter Fabric: Standard filter fabric shall be provided for installation at locations indicated on the Drawings and as specified herein. Standard filter fabric shall be a nonwoven fabric consisting of only continuous chains of polymeric filaments or yarns of polyester formed into a stable network by needle punching. The fabric shall be inert to commonly encountered chemicals; shall be resistant to mildew, rot, ultraviolet light, insects, and rodents; and shall have the indicated properties:

Property	Test Method	Unit	Min Roll Value *
Fabric Weight	ASTM D3776	oz/yd ²	5.7
Grab Strength	ASTM D4632	lb	155
Grab Elongation	ASTM D4632	percent	50
Mullen Burst Strength	ASTM D3786	psi	190
Apparent Opening Size	CW-02215	U.S. Standard Sieve Size	70

* Minimum average roll value in weakest principal direction.

PART 3 EXECUTION

3.01. OPEN CUT METHOD (TRENCHING)

- A. General: Excavations for pipelines shall be accomplished by the open cut method (trenching) except as specified or approved by the Engineer. Trenching shall be with a minimum inconvenience and disturbance to the general public. The Contractor shall sort and stockpile the excavated material so the proper material is available for backfill.
- B. Trench Depths: All trenches shall be excavated to depths required for proper pipe embedment. Overdepth excavation shall be required when the subgrade is unstable. Overdepth excavations shall be backfilled with granular pipe embedment material as specified in SECTION 2536 - SEWER PIPE INSTALLATION, unless otherwise directed by the Engineer.
- C. Preparation of Pipe Subgrade: Pipe subgrade shall be prepared after rough trenching is complete and shall be done with hand tools immediately prior to installing pipe. The bottom of the trench shall be prepared to provide uniform support of the bottom quadrant of the pipe, and bell holes or depressions shall be hand excavated where bell and spigot pipe or mechanical joint pipe is used. The trench bottom shall be evenly graded and areas that are too high shall be shaved as required. Any portions of the trench that are found to be too low shall be filled with suitable materials, thoroughly rammed and tamped and brought to true grade, allowing for placement of bedding material as shown on the Drawings.
- D. Trench Bottom in Rock Excavation: Where rock is encountered in excavating and where it is necessary to place pipe in rock excavation, the rock shall be removed to provide a minimum clearance at the side of the pipe as shown on the JCW Standard Detail Sheet.
- E. Replacement of Unsuitable Pipe Foundation Material:
 1. Where the trench bottom is found to be of a wet or otherwise unstable material, or where it is impossible to provide proper bearing for the pipe, or where it is found to be impossible to carry on construction operations due to the condition of the trench bottom, the Contractor shall remove all unstable or unsuitable material to a depth of not less than 6 inches or to a greater depth as required to provide a stable foundation below the elevation of the pipe subgrade over the entire width of the trench.

2. Materials so removed shall be replaced with granular pipe embedment material, or other material approved by the Engineer. Such material shall be thoroughly compacted by tamping or rolling over the entire width of the trench and shall be brought to proper grade, shape, and elevation for the installation of the pipe as shown on the Drawings.

F. Trench Walls:

1. Undercutting of trench walls is not permitted.
2. Where soil banks have the potential for slides, cave-ins, settlement or movement, the Contractor shall sufficiently sheet, shore and brace all sides of the excavation. The Contractor shall be responsible for the design of the sheeting, shoring and bracing and shall provide the sheeting, shoring and bracing at no additional cost to the Owner.
3. When excavations are made adjacent to existing buildings or other structures, or in paved streets or alleys, particular care shall be taken to adequately sheet, shore and brace the sides of the excavation to prevent any undermining of, or settlement beneath, the structures or the pavement. Underpinning of adjacent structures, when necessary, shall be done as required to prevent damage to adjacent structures and facilities. The foundation material which is undermined shall be replaced and compacted in accordance with the requirements of the jurisdictional agency and at no additional cost to JCW.
4. Sheeting, shoring or bracing shall not be left in place unless otherwise authorized by JCW. The removal of sheeting, shoring and bracing shall be done in such a manner as not to endanger or damage either the new structure or any existing structure or property, either private or public, and so as to avoid cave-ins or sliding of banks. If for any reason the Contractor, with the approval of JCW, leaves in place any sheeting, shoring or bracing, no payment will be made of such material left in place. All holes or voids left by the removal of sheeting, shoring or bracing shall be satisfactorily filled and compacted in accordance with the requirements of the jurisdictional agency and as directed by the Engineer at no additional cost to the Owner.

G. Trench Clearances:

1. Flexible Pipe (PVC Pipe, DIP, HDPE Pipe, and Fiberglass Wastewater Pipe):
 - a. Minimum Trench Clearance: See Table of Bedding Depths and Side Clearances in the JCW Standard Detail Drawing. For the Bedding Depths, the distance is measured from the outside face of the trench. For the Side Clearance, the distance is measured below a horizontal plane twelve (12) inches above the top of the pipeline to the outside face of the pipe barrel.
 - b. Maximum Trench Clearance:

- i. The maximum allowable trench clearances hereinafter specified apply only to that portion of the trench below the plane parallel to and twelve (12) inches above the top of the pipe.
- ii. The allowable maximum clearances may be exceeded at manholes, bore pits, tees, and in unstable earth material. Where the maximum trench width is exceeded the Contractor shall provide the appropriate strength class of pipe embedment to provide safe support strength to the pipeline.
- iii. When the side clearance exceeds two and one-half (2 ½) times the pipe's outside diameter, it shall be the Contractor's responsibility at no additional cost to the Owner to provide bedding adequate to develop the required lateral support for the pipe and/or provide a pipe of sufficient strength class to accommodate the loading conditions as approved by the Engineer.

2. Rigid Pipe (RCP):

- a. Minimum Trench Clearance: See Table of Bedding Depths & Side Clearances in the JCW Standard Detail Drawing. For the Bedding Depths, the distance is measured from the outside face of the trench. For the Side Clearance, the distance is measured below a horizontal plane twelve (12) inches above the top of the pipeline to the outside face of the pipe barrel.
 - b. Maximum Trench Clearance: The Contractor shall not exceed the maximum trench clearances recommended by the pipe manufacturer for the cover depth, soil type, loading condition and the required class of embedment.
- H. Trench Slope: The trench width above a horizontal plane twelve (12) inches above the top of the pipe may vary and side sloping is permissible unless otherwise specified.
- I. Trench Shields: When trench shields are utilized by the Contractor, said shields or any part thereof shall not extend lower than twelve (12) inches above the top of the proposed pipeline nor shall the maximum allowable trench width be exceeded.
- J. Option to Trenching: Contractor may perform excavation by tunneling methods as set forth herein, at no additional cost to the Owner provided prior written approval for each such location is obtained from the Engineer and JCW.
- K. Tunneling and Boring: All excavation required to perform the tunneling and boring as shown on the plans shall meet the requirements of SECTION 2410 - TUNNELING and SECTION 2445 - BORING.

3.02. BACKFILL

A. General

1. All trash and debris shall be removed from the pipeline excavation prior to backfilling.
2. Unless otherwise specified, all sewer trenches and excavation around structures shall be backfilled to the original surface of the ground with earth or earth and rock. When an earth and rock mixture is used, it shall be placed more than 12 inches below ground surface and shall be thoroughly consolidated with sufficient earth to completely fill all voids between the rocks.
3. The backfill material shall be placed in lifts not exceeding eight (8) inches. Each lift shall be compacted to the required density prior to the next lift being placed. The lift thickness shall be reduced as necessary to achieve the specified degree of compaction for the Contractor's compaction equipment.
4. Commercial sand backfill shall not be used.
5. Prior to finish grading and tilling, the Contractor shall restore the topsoil on the excavated areas to a depth equal to that which existed prior to excavation. At the Contractor's option, the existing topsoil shall be replaced with 1) existing topsoil placed in a segregated stockpile prior to trench excavation or 2) imported topsoil from a suitable location at no additional cost to the Owner. If less than 6 inches of topsoil exists prior to excavation, the Contractor shall, at no additional cost to the Owner, provide additional topsoil to achieve a minimum depth of 6 inches following construction. In no case shall topsoil be moved by the Contractor from one property to another on the project.
6. Backfill material shall be carefully placed to avoid damage to or displacement of the pipe and other exposed utilities or structures.
7. Backfill shall not be placed when material contains frost, is frozen, or a blanket of snow prevents proper compaction.
8. Contractor shall remove waste material, trees, organic material, rubbish, or other deleterious substances from the backfill.
9. See SECTION 2536 - SEWER PIPE INSTALLATION for pipe embedment requirements.
10. No rock greater than one (1) foot, measured along its longest axis, shall be placed within two (2) feet of the top of the pipe in any excavation as backfill. No rocks greater than one (1) foot will be allowed in the backfill above the service line terminations, tees and wyes.

- B. Backfilling In Street or Alley Right-of-way and Under Pavement: The backfill materials above the pipe embedment and under pavement or unpaved areas

within the Right-of-Way shall meet the requirements of the jurisdictional agency or the Drawings. Otherwise, under areas to be paved, the backfill materials from the top of the pipe embedment (as defined in SECTION 2536 - SEWER PIPE INSTALLATION) to a point at grade shall be compacted to at least 95% of maximum dry density at a moisture content within 2% of optimum moisture as determined by ASTM D698. Required compaction and percentage of maximum density must be obtained before pavement is placed. For pipelines located within street or alley rights-of-way, density tests representative of each three (3) feet of trench depth shall be taken at five hundred (500) linear foot intervals along the lines or at each street crossing. At least two tests shall be run.

- C. Backfilling In Areas Other Than Street or Alley Right-of-way: From the top of the pipe embedment (as defined in SECTION 2536 - SEWER PIPE INSTALLATION) to a point at grade, the backfill material shall be compacted to no less than 90% of maximum dry density at a moisture content within 2% of the optimum moisture as determined by ASTM D698. For pipelines located outside of street or alley rights-of-way, density tests representative of each three (3) foot of trench depth shall be taken at one-thousand (1,000) foot intervals along the lines.
- D. Backfill Around Structures:
 - 1. No backfill shall be placed over or around any structure or concrete encasement of the pipe until the concrete or mortar has attained a minimum strength of 2,000 psi as determined by test cylinders and can sufficiently support the loads imposed by the backfill and compaction operations without damage.
 - 2. The Contractor shall use utmost care to avoid any wedging action between the side of the excavation and the structure that would cause any movement of the structure. Any damage caused by premature or unbalanced backfill or by the use of equipment on or near a structure shall be the responsibility of the Contractor.
 - 3. No rock larger than four (4) inches maximum dimension shall be placed within one (1) foot of the exterior surface of any structure.
- E. Responsibility of Contractor for Backfill Settlement
 - 1. The Contractor shall be responsible for the satisfactory compaction and maintenance of all backfill of any description required under this Contract. If, prior to the final acceptance of this entire contract, any backfilled areas are found to have settled, they shall immediately be reworked by the Contractor and restored to the specified grades.
 - 2. Any sod, paving, or other surfacing damaged by backfill settlement prior to acceptance of the Work shall be replaced by, and at the expense of the Contractor. In addition, the Contractor shall be responsible for all damages that results from the settlement of backfill made by them in the fulfillment of this contract, within the correction period.

3. The Contractor shall be responsible for all costs to the Owner and/or JCW resulting from all claims for damages filed with and court actions against said Owner and/or JCW for and on account of such damage.
4. The Contractor shall be responsible for the repair, to the satisfaction of the Owner and/or JCW, of any pavement, curb, slab, walk, or other structure damaged by backfill settlement.

3.03. SOIL DENSITY TESTS

Compaction tests shall be performed as specified below and at the frequency defined in paragraphs 3.02.B and 3.02.C of this Section. The uppermost compaction test taken at each of the aforementioned locations shall be taken within a zone between two (2) to five (5) feet below the finished grade for that area. All compaction tests shall be performed by an independent testing laboratory approved by the Engineer.

A. Testing Methods: Testing shall be in accordance with the following:

1. Maximum Dry Density: Maximum dry density shall be determined by the standard proctor analysis method as defined by AASHTO T99 or ASTM D698. Standard proctor tests shall be taken at each change in material being excavated. It is estimated that the standard proctor tests will need to be taken on an average of one test per 1000 linear feet of the sewer line installed.
2. Density of Soil in Place: The density of soil in place shall be determined in accordance with ASTM D1556, ASTM D2167, or ASTM D6938.
3. Moisture Content: The soil moisture content of in place fill material shall be determined in accordance with ASTM D2216 or D6938.

B. Additional Tests: The Engineer may require additional density tests with payment as follows:

1. Test results conforming to specified moisture and densities will be paid for by the Owner.
2. Test results not conforming to specified moisture and densities shall be paid for by the Contractor at no additional cost to the Owner.

END OF SECTION 2315

SECTION 2410 - TUNNELING

PART 1 GENERAL

1.01. WORK INCLUDED IN THIS SECTION

This section governs furnishing and installation of pipe by the trenchless method of tunneling using steel plate liners as the initial support system. Tunneling may be accomplished by open-face mining with or without shields. Compressed air may also be required to control the entry of water into the tunnel.

1.02. SPECIFICATION MODIFICATIONS

It is understood that throughout this section these Specifications may be modified by appropriate items in the Modifications to Detailed Specifications or notes on the Contract Drawings.

1.03. REVISIONS OF STANDARDS

When reference is made to a Standard Specification i.e. ASTM, ANSI, AWWA, MCIB, the Specification referred to shall be understood to mean the latest revision of said specification as amended at the time of the Notice to Bidders, except as noted on the Drawings or in the Modifications to Detailed Specifications.

1.04. SUBMITTALS

The Contractor shall provide certifications or shop drawings on all materials provided under these specifications in accordance with the General Requirements. The Contractor shall submit the following to the Engineer prior to actual work:

- A. The Contractor shall submit for review complete working drawings showing details of the proposed method of construction and the sequence of operations to be performed during construction. Show the method of tunneling, location of drive and reception shafts, including method of excavation, shoring and bracing, and dewatering techniques that are proposed to be used. The following is not intended to limit, but to provide the minimum of, details which must be included.
 - 1. Manufacturer's literature describing in detail the tunneling system to be used.
 - 2. Method of muck or spoil disposal.
 - 3. Method(s) of controlling groundwater.
 - 4. Shaft dimensions, locations, surface construction, profile, depth, method of excavation, and shoring and bracing.
 - 5. Methods to provide safe support strength for the pipeline when the bore pits exceed maximum allowable trench widths.
 - 6. Method of supporting and restraining the carrier pipe within the tunnel during pipe installation and filling of the annular space between the tunnel lining and the carrier pipe.

- B. The Contractor shall submit a structural design of the initial support system for the tunnel signed and sealed by a Professional Engineer registered to practice engineering in state of Kansas. The structural design shall address the construction loads and the planned sequence of grouting of the tunnel liner plates as liner plate installation is ongoing. The structural design shall also define the anticipated materials being excavated. If the Contractor encounters materials to be excavated that deviate from the materials used as the basis for tunnel design, the Contractor shall submit a revised structural design signed and sealed by the same Professional Engineer.
- C. The Contractor shall provide certifications or shop drawings on all materials provided under these specifications.
- D. The Engineer shall base the review of submitted details and date the submittals with consideration of requirements for the completed work, utilities, and the possibility of unnecessary delays in the execution of the work to be constructed. Review and any acceptance of the Contractor's submittals, by the Engineer, shall not be construed in any way as relieving the Contractor of his responsibilities.
- E. As-constructed logs shall be maintained by the Contractor to document the line and grade of the tunnel. These records shall be maintained and updated at 50-foot intervals, or more frequently, as directed by the Engineer or JCW. A plot of actual and planned locations of the tunnel path shall be updated and forwarded to the Engineer on a weekly basis, or more frequently, as directed by the Engineer or JCW. Any section of the tunnel not meeting specified tolerances shall be replaced or repaired to the satisfaction of the Engineer and JCW at no cost additional cost to the Owner.

PART 2 PRODUCTS

2.01. STEEL LINER PLATE

Steel tunnel liner plates shall be new and with minimal oxidation. The design and shape of the liner plates shall be such that assembly can take place entirely from within the tunnel liner. Liner plates shall be capable of withstanding the ring thrust load and transmitting this from plate to plate. The minimum outside diameter shall be four (4) feet and the minimum wall thickness shall be United States Standard Gauge 12 (0.1094 inches). Sufficient sections shall be provided with one and one-half (1½) inch or larger grouting holes located near the centers so that when plates are installed there will be one line of holes on either side of the tunnel and one at the crown; the lower line of holes on each side shall not be more than eighteen (18) inches above the invert. The holes in each line shall not be more than five (5) feet apart and unless otherwise approved, shall be staggered. Bolts and nuts shall conform to ASTM A153, A307, A325 and A449 as applicable. Steel liner plates shall have bolted joints in both longitudinal and circumferential planes. Stagger longitudinal joints in adjacent rings when assembling.

2.02. SANITARY SEWER CARRIER PIPE

Acceptable pipe materials for installation in tunnels shall be as follows:

- A. Ductile-Iron Pipe: Shall meet the requirements of paragraph 2.02.B of SECTION 2534 - SANITARY SEWER PIPE.

- B. Reinforced Concrete Pipe (RCP): Shall meet the requirements of paragraph 2.02.F of SECTION 2534 - SANITARY SEWER PIPE.
- C. Plastic Pipe: With the approval of JCW, the following plastic pipe materials will be allowed on a case-by-case basis:
 - 1. Polyvinyl Chloride (PVC) Pipe: Shall meet the requirements of paragraph 2.02.C, paragraph 2.02.D, or paragraph 2.02.E of SECTION 2534 - SANITARY SEWER PIPE.
 - 2. High Density Polyethylene (HDPE) Pipe for Force Main: Shall meet the requirements of paragraph 2.02.H of SECTION 2534 - SANITARY SEWER PIPE.
 - 3. Fiberglass (Glass-Fiber-Reinforced Thermosetting-Resin) Wastewater Pipe: Shall meet the requirements of paragraph 2.02.G of SECTION 2534 - SANITARY SEWER PIPE.

2.03. SUPPORT OF PIPE IN TUNNEL

The Contractor shall provide a permanent support of the pipe within the limits of the tunnel. The support shall not be reactive with the carrier pipe material and shall provide sufficient restraint to prevent the carrier pipe from movement during installation of the liner fill.

2.04. LINER FILL

- A. Short to Medium Length Tunnels (800 feet or less): The annular space between the tunnel liner plates and the carrier pipe shall be filled with a grout fill. The grout fill shall be an engineered grout, Elastizell "PS Lightweight Cellular Concrete" or approved equal, with the following properties:
 - 1. Cast Density - 38 pcf
 - 2. Maximum Compressive Strength at 28 days - 120 psi
- B. Long Tunnels (greater than 800 feet): The Contractor shall propose a liner fill that is appropriate for the installation to JCW for approval.

2.05. BRICK AND MORTAR END SEALS

End seals shall be provided as indicated on the Drawings for all gravity sewer applications. The brick shall meet the requirements of ASTM C32, Grade SS or SM. The mortar shall meet the requirements of ASTM C270.

PART 3 EXECUTION

3.01. GENERAL

- A. Tunneling shall be done with a minimum inconvenience and disturbance to the general public and abutting property owners.

- B. Where pipe is required to be installed under railroad embankments or under highways, streets, or other facilities by trenchless methods, construction shall be made in such a manner that will not interfere with the operation of the railroad, street, highway, or other facility, and shall not weaken or damage any embankments or structure. During construction operations, barricades and lights to safeguard traffic and pedestrians shall be furnished and maintained until such time as the backfill has been completed and then shall be removed from the site.
- C. Any pipe damaged during the operations shall be removed and replaced by the Contractor at his expense.

3.02. SITE SAFETY

- A. Barricades and Lights: The Contractor shall erect and maintain such barricades, construction signs, torches, red lanterns and guards as may be required to protect persons from injury and to avoid property damage during the construction period and until it is safe for traffic to use the facilities. Rules and regulations of the local authorities respecting safety provisions shall be observed. All construction signs and traffic controls shall be in accordance with the "Manual on Uniform Traffic Control Devices" (DOT-FHWA).
- B. The Contractor shall maintain and enforce all safety precautions required by the Occupational Safety and Health Act including rules 29 CFR Part 1926, Subpart P regarding excavations and trenches and 29 CFR 1910.146 regarding confined spaces. Air monitoring of the shafts or pits shall be conducted on a continuous basis.

3.03. EXCAVATION, SETTLEMENT AND HEAVE MONITORING, AND BACKFILLING

- A. The excavation and backfill for pits and installation of shoring shall be as outlined in SECTION 2230 - SITE PREPARATION AND EXCAVATION and SECTION 2315 - TRENCHING AND BACKFILLING. Perform dewatering and chemical soil stabilization or grouting if necessary, due to existing field conditions.
- B. The tunnel shall be excavated in such a manner and to such dimensions which will permit placing of the proper supports necessary to protect the excavation. The Contractor shall take proper precautions to avoid excavating earth or rock or shattering rock beyond the limits of the excavation. All damages caused by excavating or blasting, either to surface or subsurface structures shall be repaired by the Contractor at his own cost and expense.
- C. Suitable pit shafts or trenches shall be excavated for the purpose of conducting trenchless operations and for placing end joints of the pipe. Wherever end trenches are cut in the sides of an embankment or beyond it, such work shall be sheeted and securely braced in a manner satisfactory to the Engineer to prevent earth caving.
- D. The pits or trenches excavated to facilitate the operations shall be backfilled immediately after the pipe has been installed.
- E. Suitable steel or timber sheeting, shoring, and bracing shall be used to support the sides and roof of the excavation. Supports may be left in place provided that

they clear the minimum thickness of the concrete backfill around the pipe. No separate payment will be made for supports left in place.

- F. The removal of any obstruction that may be found to conflict with the placing of the pipe shall not be measured for payment nor paid for as a separate contract pay item. The removal of any such obstruction shall be included in the cost of other items.
- G. The total maximum permissible settlement or heave at any point within 50 feet either side of the centerline of the tunnel shall be 1½ inches. The Contractor shall monitor any ground movements associated with the work twice a day. Prior to and one (1) year after final acceptance of the Work the Contractor shall check for settlement or heave that exceeds the total maximum allowance. Surface settlement and heave monitoring points for railroad crossings shall be located at the top of each rail. Surface settlement and heave monitoring points for roadway and highway crossings shall be located at the center of each traffic lane. The Contractor shall install instrumentation, take readings, and provide the Engineer with copies of the settlement and heavy monitoring. These actions are meant to supplement the Contractor's monitoring system and do not relieve the Contractor of his responsibility, nor place on the Engineer, responsibility for control of ground movement and protection of the work and adjacent structures. Any damages to existing facilities due to settlements or heaves which exceed 1 ½ inches shall be repaired to the satisfaction of the owner of the facility at no additional cost to the Owner.

3.04. LINER PLATE INSTALLATION

- A. Liner plates shall be assembled immediately following the excavation. Advance liner plates continuously with excavation. When liner plates are being installed, care shall be taken to maintain alignment, grade and circular shape of the tunnel.
- B. All voids between the liner and surrounding earth shall be filled with grout forced under pressure. As the pumping through any hole is stopped, it shall be plugged to prevent backflow of grout. Grouting shall be performed in a sequence which will preclude deflections exceeding 5 percent of the tunnel diameter.
- C. After lining installation is complete, it shall be cleaned of all debris and all leaks, which allow flowing or seeping water into the tunnel, shall be stopped.
- D. The bottom portion of the tunnel liner shall be provided with a paved invert as required for the installation of the carrier pipe.

3.05. CARRIER PIPE INSTALLATION

- A. After completion of the installation of the tunnel liner plate, the carrier pipe shall be joined per manufacturer's recommendations and carefully pushed or pulled through the tunnel in a manner that will maintain proper jointing of the pipe joints and provide required grade and alignment as evidenced by a minimum of 3/4 of a full moon seen during a lamping inspection.
- B. The Contractor shall provide a permanent support of the pipe within the limits of the tunnel. The support shall not be reactive with the carrier pipe material and

shall provide sufficient restraint to prevent the carrier pipe from movement during installation of the liner fill.

3.06. TOLERANCE

The method of tunneling and pipe installation shall be capable of maintaining the grade within the tolerances shown on the Drawings over the total distance between the access pits.

3.07. TESTING

The carrier pipe shall pass an exfiltration test prior to installing end seals and filling the void between the liner plates and carrier pipe.

3.08. END SEALS

Construct and/or install the end seals after sewer pipe has been installed, tested, and approved.

3.09. LINER FILL

The grout fill for the liner shall be installed as follows:

- A. The cellular concrete grout shall be installed in accordance with the procedures provided by the certified applicator and approved by the Engineer.
- B. The Contractor shall employ measures and monitoring necessary to ensure the temperature of the grout as it cures does not exceed the allowable temperature for the carrier pipe.
- C. The batching, mixing, and placing equipment shall be suitable for application and certified by the manufacturer of the expansion material.
- D. Pressure and material density used in grouting shall be sufficient to dispel water and fill all voids but shall not distort or damage any portions of the Work or existing structures and installations.
- E. During placement of the initial batches, the density shall be checked and the grout mix adjusted as required to obtain the specified cast density.
- F. Four (4) test specimens for each 300 cubic yards of grout or for each four (4) hours of placing shall be taken. The specimens shall be tested in accordance with ASTM C495 except:
- G. The specimens shall be 3" x 6" cylinders covered after casting to prevent damage and loss of moisture. Moist cure specimens until two (2) days prior to compressive strength testing. Specimens that are load tested shall not be oven-dried.

END OF SECTION 2410

SECTION 2445 - BORING

PART 1 GENERAL

1.01. WORK INCLUDED IN THIS SECTION

This section governs furnishing and installation of pipe by the trenchless method of boring, in conformity with these Specifications. Boring consists of the initial installation of a new steel or reinforced concrete casing pipe, installed mechanically, with a suitable assembly designed to produce a smooth, straight shaft at the established line and grade. A carrier pipe is then installed inside the casing pipe. Any trenchless method of construction not utilizing a steel or reinforced concrete casing pipe shall not be considered a boring operation.

1.02. SPECIFICATION MODIFICATIONS

It is understood that throughout this section these Specifications may be modified by appropriate items in the Modifications to Detailed Specifications or notes on the Contract Drawings.

1.03. REVISIONS OF STANDARDS

When reference is made to a Standard Specification i.e. ASTM, ANSI, AWWA, MCIB, the Specification referred to shall be understood to mean the latest revision of said specification as amended at the time of the Notice to Bidders, except as noted on the Drawings or in the Modifications to Detailed Specifications.

1.04. SUBMITTALS

The Contractor shall provide certifications or shop drawings on all materials provided under these specifications in accordance with the General Requirements. The Contractor shall submit the following to the Engineer prior to actual work:

- A. The Contractor shall submit for review complete working drawings showing details of the proposed method of construction and the sequence of operations to be performed during construction. Show the method of boring, location of drive and reception shafts, including method of excavation, shoring and bracing, and de-watering techniques that are proposed to be used. The following is not intended to limit, but to provide the minimum of, details which must be included.
 1. Manufacturers' literature describing in detail the tunneling system to be used
 2. Method of muck or spoil disposal
 3. Method(s) of controlling groundwater
 4. Shaft dimensions, locations, surface construction, profile, depth, method of excavation, and shoring and bracing
 5. Methods to provide safe support strength for the pipeline when the bore pits exceed maximum allowable trench widths.

- B. All Contractor submittals requiring structural design shall be signed and sealed by a Professional Engineer, registered to practice engineering in state of Kansas.
- C. The Contractor shall provide certifications or shop drawings on all materials provided under these specifications.
- D. The Engineer shall base the review of submitted details and date with consideration of requirements for the completed work, utilities, and the possibility of unnecessary delays in the execution of the Work to be constructed. Review and acceptance of the Contractor's submittals, by the Engineer, shall not be construed in any way as relieving the Contractor of their responsibilities.

PART 2 PRODUCTS

2.01. STEEL CASING PIPE

Steel casing for bored or jacked construction shall be new steel pipe conforming to ASTM A139 with a minimum diameter as shown on the Drawings.

- A. Unless otherwise shown on the Drawings, the casing pipe minimum wall thickness shall be in accordance with the following table:

Diameter of Casing-Inches	Nominal Wall Thickness in Inches		<u>All Other Uses</u>
	(with approved Exterior Coating or Cathodically Protected)	(without Corrosion Protection)	
16	0.250	0.281	0.188
18	0.250	0.375	0.250
20	0.281	0.375	0.250
22	0.281	0.376	0.250
24	0.312	0.438	0.281
26	0.344	0.438	0.281
28	0.375	0.501	0.312
30	0.406	0.501	0.312
32	0.438	0.532	0.312
34	0.469	0.563	0.312
36	0.469	0.594	0.344
42	0.562	0.625	0.344
44	0.594	0.719	0.438
46	0.594	0.719	0.438
48	0.625	0.751	0.438
50	0.656	0.782	0.500
52	0.688	0.813	0.500
54	0.719	0.781	0.500
56	0.750	0.812	0.500
58	0.750	0.812	0.500
60	0.781	0.844	0.500
64	0.844	0.906	0.625
66	0.875	0.938	0.625
68	0.875	0.938	0.750
70	0.906	0.969	0.750
72	0.938	1.000	0.750

- B. The Contractor shall furnish and install any corrosion control measures on casings under railroads as shown on the Drawings.
- C. Steel shall be Grade B with a minimum yield strength of 35,000 psi under railroads and Grade A on all other uses.
- D. Steel pipe shall have welded joints in accordance with AWWA C 206.

2.02. REINFORCED CONCRETE CASING PIPE

When permitted by the owner of the railroad or highway being crossed, reinforced concrete pipe used as casing shall conform to ASTM C76 except as otherwise specified under SECTION 2534 - SANITARY SEWER PIPE and as specified herein.

- A. Design: Provide ASTM C76 circular pipe of the minimum strength class required by the owner of the railroad or highway being crossed or required for the jacking of pipe when determined by method set forth in the latest printing of Concrete Pipe Design Manual prepared by the American Concrete Pipe Association.
- B. Joints: Reinforced concrete pipe used for casing pipe shall be provided with steel end joint with a groove in the spigot end for an O-ring gasket. The O-ring gasket shall be synthetic rubber. Both joint and gasket shall otherwise conform to ASTM C361.
- C. Interior Protection: Interior protection is not required for reinforced concrete pipe used for casing conduit.

2.03. SANITARY SEWER CARRIER PIPE

- A. For installation in bored casing pipes 200' in length and less, the acceptable pipe materials shall be as follows:
 - 1. Ductile-Iron Pipe: Shall meet the requirements of paragraph 2.02.B of SECTION 2534 - SANITARY SEWER PIPE.
 - 2. Reinforced Concrete Pipe (RCP): Shall meet the requirements of paragraph 2.02.F of SECTION 2534 - SANITARY SEWER PIPE.
 - 3. Plastic Pipe: With the approval of JCW, the following plastic pipe materials will be allowed on a case-by-case basis:
 - a. Polyvinyl Chloride (PVC) Pipe: Shall meet the requirements of paragraph 2.02.C, paragraph 2.02.D, or paragraph 2.02.E of SECTION 2534 - SANITARY SEWER PIPE.
 - b. High Density Polyethylene (HDPE) Pipe for Force Main: Shall meet the requirements of paragraph 2.02.H of SECTION 2534 - SANITARY SEWER PIPE.
 - c. Fiberglass (Glass-Fiber-Reinforced Thermosetting-Resin) Wastewater Pipe: Shall meet the requirements of paragraph 2.02.G of SECTION 2534 - SANITARY SEWER PIPE.

- B. For installation in bored casing pipes greater than 200' in length, the acceptable pipe materials shall be ductile iron pipe meeting the requirements of paragraph 2.02.B of SECTION 2534 - SANITARY SEWER PIPE.

2.04. SUPPORT OF PIPE IN BORING

The carrier pipe shall be supported in the tunnel by one of the following means:

- A. Wood Skids: Wood skids shall be provided as indicated on the Drawings. The wood shall be pressure-treated to resist rotting. Cut surfaces shall be given two (2) heavy brush coats of the same preservative used to pressure-treat the wood. If PVC pipe is used as the carrier pipe, the wood skids shall be compatible with the PVC pipe.
- B. Adjustable Casing Spacers: Adjustable casing spacers are shall be custom-manufactured for gravity sewer and force main installation in the same casing pipe. Adjustable casing spacers shall be installed in such a manner as to insure that the grade indicated on the plans is maintained. In the event that the grade of the carrier pipe is not maintained throughout the casing the Contractor shall, at no additional cost to the Owner, remove the carrier pipe and replace it in the casing at the grade indicated on the plans.

1. Material requirements are as follows:

- a. Band and Risers
 - i. Band: 14-gauge T-304 Stainless Steel
- b. Liner: EPDM
 - i. Minimum thickness: 0.090"
 - ii. Minimum hardness: Durometer "A" 85 - 90
 - iii. Dielectric strength (1/8" thick): 60,000 VPM
 - iv. Water absorption: 1 % maximum
 - v. Overlap edges
- c. Studs, Nuts, and Washers
 - i. Stud and nut materials: T-304 Stainless Steel
 - ii. Washers: SAE 2330
- d. Runners
 - i. 2" wide glass filled polymer
 - ii. Length: 7 inches
 - iii. Height: effective height shall be as required to insure that the grade indicated on the plans is maintained

2. Adjustable casing spacer material shall conform to the following specifications:
 - a. Rockwell hardness (M) (ASTM D785): 100
 - b. Tensile Strength (ASTM D638): 27,000 psi
 - c. Flexural Strength (ASTM D790): 40,000 psi
 - d. Compression Strength (ASTM D695): 33,000 psi
 - e. Deflection Temperature @ 264 psi (ASTM D648): 478°F
 - f. Deformation Under Load @ 1220° F (50° C) 4000 lb. load (ASTM D648): 1.2%
 - g. Coefficient of Friction: 0.1

2.05. LINER FILL

Liner fill shall be one of the following materials:

- A. Sand Fill: Sand used as fill in tunnels shall be a clean sand and thoroughly dry. All sand fill shall be natural sand meeting the requirements of ASTM C33, Fine Aggregate. Manufactured and artificial sands will not be accepted.
- B. Grout Fill: Grout fill shall be an engineered grout, Elastizell "PS Lightweight Cellular Concrete" or approved equal, with the following properties:
 1. Cast Density - 30 ± 3 pcf
 2. Maximum Compressive Strength at 28 days - 80 psi

2.06. CASING PIPE END SEALS

- A. Brick and Mortar End Seals: End seals shall be provided as indicated on the Drawings for all gravity sewer applications. The brick utilized on gravity sewer applications shall meet the requirements of ASTM C32, Grade SS or SM. The mortar shall meet the requirements of ASTM C270.
- B. Fabricated End Seals:
 1. End seal for force main applications shall be a wrap around end seal manufactured of 1/8" thick neoprene rubber fastened to the steel casing pipe and to the carrier pipe by 1/2" wide T304 stainless steel banding with a 100% non-magnetic worm gear mechanism. The end seal shall be manufactured with butyl mastic strips to seal edges.
 2. Physical Properties
 - a. Temperature Limits -20° F to +212° F
 - b. Color black
 - c. Finish smooth

d.	Durometer	60 +/- 5
e.	Average Tensile	1000 psi
f.	Average Elongation	350%
g.	Specific Gravity	1.5
h.	Polymer Content	20%

PART 3 EXECUTION

3.01. GENERAL

- A. Boring shall be done with a minimum inconvenience and disturbance to the general public and abutting property owners, yet providing an adequate work area.
- B. Where pipe is required to be installed under railroad embankments or under highways, streets, or other facilities by trenchless methods, construction shall be made in such a manner that will not interfere with the operation of the railroad, street, highway, or other facility, and shall not weaken or damage any embankments or structure. During construction operations, barricades and lights to safeguard traffic and pedestrians shall be furnished and maintained until such time as the backfill has been completed and then shall be removed from the site.
- C. Any pipe damaged during the operations shall be removed and replaced by the Contractor at their expense.
- D. At the onset of the work, the Contractor shall confirm the presence and location of existing underground utilities within the proposed boring alignment. Information shown on the Drawings, if any, is subject to confirmation by the Contractor prior to the start of the work on the bore. If unanticipated conflicts are found to exist, the Contractor shall notify the Engineer immediately and propose modifications to the boring locations if required.

3.02. SITE SAFETY

- A. **Barricades and Lights:** The Contractor shall erect and maintain such barricades, construction signs, torches, red lanterns and guards as may be required to protect persons from injury and to avoid property damage during the construction period and until it is safe for traffic to use the facilities. Rules and regulations of the local authorities respecting safety provisions shall be observed. All construction signs and traffic controls shall be in accordance with the "Manual on Uniform Traffic Control Devices" (DOT-FHWA).
- B. The Contractor shall maintain and enforce all safety precautions required by the Occupational Safety and Health Act including rules 29 CFR Part 1926, Subpart P regarding excavations and trenches and 29 CFR 1910.146 regarding confined spaces. Air monitoring of the shafts or pits shall be conducted on a continuous basis.

3.03. EXCAVATION, SETTLEMENT AND HEAVE MONITORING, AND BACKFILLING

- A. The excavation and backfill for pits and installation of shoring shall be as outlined in SECTION 2230 - SITE PREPARATION AND EXCAVATION and SECTION 2315 - TRENCHING AND BACKFILLING. Perform dewatering and chemical soil stabilization or grouting if necessary, due to existing field conditions.
- B. The boring for the casing shall be excavated in such a manner and to such dimensions that will permit placing of the proper supports necessary to protect the excavation. The Contractor shall take proper precautions to avoid excavating earth or rock or shattering rock beyond the limits of the excavation. All damages caused by excavating or blasting, either to the surface or subsurface structures, shall be repaired by the Contractor at their cost and expense.
- C. Suitable pit shafts or trenches shall be excavated for the purpose of conducting trenchless operations and for placing end joints of the pipe. Wherever end trenches are cut in the sides of an embankment or beyond it, such work shall be sheeted and securely braced in a manner satisfactory to the Engineer or the jurisdiction having authority over the right-of-way to prevent earth caving.
- D. The pits or trenches excavated to facilitate the operations shall be backfilled immediately after the pipe has been installed.
- E. Suitable steel or timber sheeting, shoring, and bracing shall be used to support the sides of the bore pit excavation. Supports may be left in place provided that they clear the minimum thickness of the concrete backfill, if required, around the pipe. No separate payment will be made for supports left in place.
- F. The removal of any obstruction that may be found to conflict with the placing of the pipe shall not be measured for payment nor paid for as a separate contract pay item. The removal of any such obstruction shall be included in the cost of other items.
- G. The total maximum permissible settlement or heave at any point within 50 feet either side of the centerline of the boring shall be 1/4 inch. If at any time during the process of installing a bore under a railroad track, settlement exceeds the 1/4 inch maximum, the Contractor shall notify the Roadmaster of the affected railroad. The Contractor shall monitor and record in a log book any ground movements associated with the work twice a day. Prior to and three (3) year after final acceptance of the Work, the Contractor shall check for settlement or heave that exceeds the total maximum allowance. Surface settlement and heave monitoring points for railroad crossings shall be located at the top of each rail. Surface settlement and heave monitoring points for roadway and highway crossings shall be located at the center of each traffic lane. The Contractor shall install instrumentation, take readings, and provide the Engineer with copies of the settlement and heave monitoring. These actions are meant to supplement the Contractor's monitoring system and do not relieve the Contractor of the responsibility, nor place on the Engineer, responsibility for control of ground movement and protection of the Work and adjacent structures. Any damages to existing facilities due to settlements or heaves that exceed 1/4 inch shall be repaired to the satisfaction of the owner of the facility at no additional cost to the Owner.

- H. The introduction of water into the excavation shall be prohibited. The use of water or other fluids in connection with the boring operation shall only be permitted when approved by the Engineer.

3.04. CASING PIPE INSTALLATION

- A. Casing shall be installed by a combination of augering and jacking. Boring without the concurrent installation of a casing pipe shall not be permitted. Casing pipe shall extend through the entire fill and be installed in a manner that shall not disrupt traffic nor damage roadway grade and surface.
- B. The diameter of the bored hole shall not exceed the outside diameter of the casing pipe to be installed more than one (1) inch. If the one (1) inch over-excavation allowance is exceeded, the Contractor shall, at no additional expense to the Owner, grout the annular space surrounding the casing pipe with the casing conduit grout defined in paragraph 2.05 of this Section.
- C. Installation of casing pipe shall be supervised by a foreman experienced in such work. Alignment and grade of casing pipe shall be such that the carrier pipe can be installed to line and grade shown on the Drawings.
- D. All joints in casing pipe shall be welded. Welding shall be performed by a person experienced with the type of welding necessary. All welds shall conform to the requirements of AWWA C 206.

3.05. CARRIER PIPE INSTALLATION

- A. After completion of the installation of the casing pipe, the carrier pipe shall be joined per manufacturer's recommendations and carefully pushed or pulled through the casing pipe in a manner that will maintain proper jointing of the pipe joints and provide required grade and alignment as evidenced by a minimum of 3/4 of a full moon seen during a lamping inspection.
- B. Wood Skids: If the Contractor chooses to use wood skids for pipe support, the wood skids shall be provided as indicated on the Drawings and shall be trimmed as necessary to maintain the required grade and alignment within the casing pipe.
- C. Adjustable Casing Spacers: If the Contractor chooses to use adjustable casing spacers for pipe support, the adjustable casing spacers shall be securely installed on the pipe and spaced according to the manufacturer's recommendations. At a minimum, three (3) adjustable casing spacers shall be used on each piece of pipe, one at each end and one at the midpoint. The adjustable casing spacers shall be adjusted as necessary to maintain the required grade and alignment within the casing pipe.

3.06. USED OR DAMAGED CASING PIPE

Casing pipe damaged during the boring and jacking process shall be pushed or pulled out and replaced with new pipe. The method of replacement shall be approved by the Engineer. All casing pipe that has been jacked previously and has been pushed or pulled out of the ground shall be replaced with new pipe.

3.07. TOLERANCE

The method of boring and pipe installation shall be capable of maintaining grade within the tolerances shown on the Drawings over the total distance between access pits.

3.08. TESTING

The carrier pipe shall pass an exfiltration test prior to installing the end seals on the casing and filling the void between the casing pipe and carrier pipe.

3.09. END SEALS

Install brick and mortar end seals or fabricated end seals after carrier pipe has been installed, tested, and approved by the Engineer.

3.10. LINER FILL

The liner fill shall be installed using one of the following methods:

- A. Sand Fill: The annular space between lining and carrier pipe shall be filled with clean sand from end seal to end seal unless otherwise specified. The fill shall be placed inside the liner, in a manner that will not disturb the alignment and/or grade of the carrier pipe. Sand shall be blown into the liner so that all space is filled.
- B. Grout Fill:
 - 1. The cellular concrete grout shall be installed in accordance with the procedures provided by the certified applicator and approved by the Engineer.
 - 2. The Contractor shall employ measures and monitoring necessary to ensure the temperature of the grout as it cures does not exceed the allowable temperature for the carrier pipe.
 - 3. The batching, mixing, and placing equipment shall be suitable for application and certified by the manufacturer of the expansion material.
 - 4. Pressure and material density used in grouting shall be sufficient to dispel water and fill all voids but shall not distort or damage any portions of the Work or existing structures and installations.
 - 5. During placement of the initial batches, the density shall be checked and the grout mix adjusted as required to obtain the specified cast density.
 - 6. Four (4) test specimens for each 300 cubic yards of grout or for each four (4) hours of placing shall be taken. The specimens shall be tested in accordance with ASTM C495 except:
 - 7. The specimens shall be 3" x 6" cylinders covered after casting to prevent damage and loss of moisture. Moist cure specimens until two (2) days prior to compressive strength testing. Specimens that are load tested shall not be oven-dried.

END OF SECTION 2445

SECTION 2530 - MANHOLES AND SPECIAL STRUCTURES

PART 1 GENERAL

1.01. WORK INCLUDED IN THIS SECTION

- A. This section governs the furnishing of all labor, equipment, tools, and materials, and the performance of all work incidental to the construction of manholes and special sewer structures. Standard manholes and special structures shall be constructed complete with covers, steps, fittings and appurtenances as required in accordance with the Drawings and Modifications to Detailed Specifications.
- B. As used herein, special structures refer to special junction structures, metering stations, vaults, and similar structures constructed on the pipeline. Manholes and special structures may be constructed of pre-cast concrete sections or cast-in-place concrete, unless otherwise noted on the Drawings or Modifications to Detailed Specifications.
- C. Cast-in-place concrete shall conform to SECTION 3000 - CAST-IN-PLACE CONCRETE of these specifications.
- D. Drop manholes are considered to be special structures and shall only be allowed if approved by JCW.

1.02. SPECIFICATION MODIFICATIONS

It is understood that throughout this section these Specifications may be modified by appropriate items in the Modifications to Detailed Specifications or notes on the Contract Drawings.

1.03. REVISIONS OF STANDARDS

When reference is made to a Standard Specification i.e. ASTM, ANSI, AWWA, MCIB, the Specification referred to shall be understood to mean the latest revision of said specification as amended at the time of the Notice to Bidders, except as noted on the Drawings or in the Modifications to Detailed Specifications.

1.04. SUBMITTALS

The Contractor shall provide certifications or shop drawings on all materials provided under these specifications in accordance with the General Requirements.

PART 2 PRODUCTS

2.01. MANHOLE MATERIALS

- A. Pre-cast Concrete Structures & Components: Pre-cast concrete manholes or structures shall conform to ASTM C478 with the following modifications.
 - 1. Manhole Wall Thickness: Wall thickness shall not be less than five (5) inches, or shall be one-twelfth (1/12) of inside diameter plus one (1) inch, whichever is greater.

2. Concrete: Cement, fine aggregate, coarse aggregate, and water used in the manufacture of pre-cast manholes shall be as specified in SECTION 3000 - CAST-IN-PLACE CONCRETE.
3. Precast Bases:
 - a. Monolithically Cast Base: A pre-cast riser section monolithically cast with an integral floor slab shall be used unless prior approval is obtained from the Engineer. The floor shall be a minimum of eight (8) inches thick.
 - b. Developed Base: With JCW approval, a developed base may be used. The developed base shall be manufactured at the manhole supplier's shop and shall consist of a pre-cast wall section embedded into a cast base. The floor of developed base manholes shall have a minimum thickness of twelve (12) inches. The bottom wall section shall be embedded a minimum of five (5) inches into the cast base.
 - c. Base Diameter: The diameter of the base pad shall be eight (8) inches greater than outside diameter of the manhole.
4. Pipe Openings: The first riser (barrel) section shall be provided with circular openings with continuous, circular, resilient connectors cast into the riser wall.
5. Horseshoe-shaped boxouts, or doghouses, shall not be allowed except when approved by JCW.
6. Gaskets: Pipe openings shall contain flexible manhole to pipe gaskets conforming to the requirements of ASTM C923. Flexible connector gaskets shall be manufactured by the Press-Seal Gasket Corporation or the A-LOK Products Inc. The following gaskets may be used for the following pipe diameters and manhole diameters:

Allowed Minimum Manhole Diameter*

Pipe Diameter	A-LOK Products, Inc.		Press-Seal Gasket Corporation
	A-LOK X-CEL	Z-LOK	PSX Direct Drive Boot Gasket
8" to 15"	4'	4'	4'
18"	4'	NA	4'
21"	4'	NA	4'
24"	4'	NA	6'
30"	5'	NA	6'
36"	6'	NA	8'
42"	6'	NA	NA
48"	8'	NA	NA
54"	8'	NA	NA
60"	8'	NA	NA
66"	10'	NA	NA
72"	12'	NA	NA
Max. Pipe Slope	17% (10°)	46% (25°)	28% (16°)

NA = Not Available

* Minimum manhole diameters shown are for straight through manholes. Manhole diameters actually required shall be based on the following factors: actual pipe O.D., distance between adjacent pipes, manhole depth, and gasket requirements.

- a. For connections to existing concrete manholes, the PSX Direct Drive Boot Gasket shall be used in conjunction with a cored hole in the existing manhole wall. Connections to existing brick or block manholes shall be as directed by JCW.
 - b. When RCP is used with an A-LOK X-CEL gasket, the barrel of the RCP shall be lubricated to prevent damage to the gasket during insertion.
 - c. When PSX gaskets are used, the take-up screws for the gasket clamps shall be positioned a minimum of 90° apart.
7. Pipe/Base Separation: The minimum distance from the outside diameter of the downstream pipe to the top inside surface of the base shall be three (3) inches. This distance shall be increased as required for proper gasket installation.
8. Joints
- a. Joints between precast manhole sections shall be sealed with preformed butyl joint sealants meeting the requirements of ASTM C990. The minimum butyl rubber content of the joint sealant shall be 60 percent butyl rubber, shall contain 2 percent or less volatile

matter, and shall have a minimum bead dimension of 1 square inch. The minimum amount of material for each joint is a function of the type of precast joint and shall be submitted for approval to the Engineer but in no case shall be less than a double bead. The sealant shall be placed at the elbow of the section's joint. The sealant shall be butt-joined and not lapped. Preformed joint sealants shall remain flexible at temperatures as low as 0° F.

- b. Joints below the cone section may be O-ring gasketed. O-Ring gaskets shall be either mastic gaskets which comply with ASTM C990 or synthetic rubber gaskets which comply with ASTM C361, Section 6.9.1. The synthetic rubber gaskets will have a hardness of 40+- 5 when measured by ASTM D2240, Type A durometer. Natural rubber will not be accepted.

9. Riser Rings:

- a. Manholes within Pavement: If JCW approves the installation of a manhole in a paved area, recycled rubber riser rings shall be used. The rubber risers shall be manufactured and intended for use as sewer appurtenances and shall consist of not less than eighty percent (80%) by weight of recycled rubber tires. The diameter of the rubber risers shall be as required to properly fit and adjust the casting ring. The thickness of a rubber riser ring shall not be less than one (1) inch or greater than four (4) inches. The joints between the cone, riser rings, and casting shall be sealed with a manufacturer-supplied sealant and adhesive that is a polyurethane compound designed for use with concrete materials and shall be resistant to ice melt chemicals and corrosion.
- b. Manholes outside of Pavement: Riser rings for manholes not within pavement may be either recycled rubber riser rings as specified in paragraph 2.01.A.9.a above or pre-cast concrete riser rings. Pre-cast concrete riser rings shall be either 4 inches or 6 inches in thickness. The joints shall be sealed with a double bead of preformed butyl joint sealant. The use of light-weight concrete with fiber reinforcement is recommended. Reinforcing shall conform to ASTM C478. Tongue and groove joints on the riser rings and the adjacent cone section shall not be allowed.

10. Lifting Notches: Precast sections may be provided with lifting notches on the inside faces of walls to facilitate handling. Lifting notches shall be not more than 3 inches [75 mm] deep; holes extending through the wall or placed on the exterior of the wall of the structure shall not be allowed.

11. Marking: The following information shall be legibly marked on each pre-cast manhole section:

- a. Manhole and specification designation
- b. Date of manufacture

- c. Name or trademark of manufacturer
 - d. Marking shall be indented into the manhole bases, risers, and cone sections or shall be painted thereon with waterproof paint.
12. Joint Sleeves: All precast manhole joints shall be wrapped with one of the following sleeves or as indicated on the Drawings:
- a. Butyl Joint Wraparound Sleeves: The butyl component of the wrap shall consist of 50 percent minimum butyl rubber and shall contain 2 percent or less of volatile matter, and shall be 0.035" inch thick. The backing component shall be EPDM rubber that is a minimum of 0.045" thick. A release paper may be used. The butyl rubber-based wrap shall be EZ-Wrap Rubber as supplied by Press-Seal Gasket Corporation, or approved equal.
 - b. Heat Shrinkable Wraparound Sleeves: The wrap system shall consist of a two-piece sleeve (backing and adhesive) with a closure system and a G-type primer. It shall consist of an irradiated cross-linked polyethylene sheeting, pre-coated with a layer of anti-corrosion adhesive. The backing shall have a minimum recovery of 22 percent. The wrap shall have a mastic type adhesive, specially formulated to become fluid at temperatures achieved during installation and maintain flexibility in cold climates with installation temperatures down to -40° F. Upon cooling the adhesive shall form a tough, elastomeric protective layer. The wrap shall employ a closure seal to allow sealing of the overlap area. The overall thickness of an applied sleeve shall nominally measure 0.01 inch. The heat shrinkable wraparound sleeves shall be "Wrapid Seal" as manufactured by Canusa or approved equal.
13. Flat Slab Tops and Reducer Tops: All flat slab tops and reducer tops shall be designed to withstand HS20 loadings regardless of the installation.
- B. Cast-In-Place-Concrete: Concrete for use in cast-in-place structures shall meet the requirements as provided in SECTION 3000 - CAST-IN-PLACE CONCRETE or as specified on the Drawings.
 - C. Reinforcement Steel: Reinforcement steel for use in cast-in-place concrete shall conform to the requirements of SECTION 3000 - CAST-IN-PLACE CONCRETE.
 - D. Grout
 - 1. Non-Shrink Grout: Non-shrink grout shall be allowed only for repair of lifting notches and for the installation of new sewers into existing brick manholes. Any other use of non-shrink grout shall be approved by JCW. Non-shrink grout shall meet the requirements of paragraph 2.14 of SECTION 3000 - CAST-IN-PLACE CONCRETE.
 - 2. Repair Grout: Repair grout shall only be allowed upon approval by JCW. Repairs of leaks in manholes shall be by pressure grouting or by

rebuilding the manhole. The grout shall be urethane gel, hydrophilic polymer, Scotch-Seal 5610 with reinforcing agent supplied by the same manufacturer, Scotch-Seal 5612. When wet, the gel shall exhibit at least 25 psi tensile strength at 150 percent elongation. The material shall not change more than eight percent in linear dimensions when subjected to cycles of wetting and drying. All materials shall be handled, mixed, and applied in accordance with the manufacturer's recommendations. Holes shall be drilled through the manhole wall to the exterior of the manhole through which the grout shall be injected using suitable probes. Grouting from the ground surface will not be allowed. The grouting pressure shall not damage the manhole, structure, or surrounding ground.

- E. Iron Castings: All casting shall conform to the requirements of ASTM A48, Class 30B. All castings shall be manufactured true to pattern and component parts shall fit tight. All castings shall be of uniform quality, free from blow holes, shrinkage, parting fins, pouring gates or other defects.
1. Rings and Covers: Rings and covers shall meet the following minimum requirements.
 - a. The standard manhole cover shall meet the requirements set forth on JCW Sheet No. MH02 in SECTION 2531 - JCW MANHOLE RING AND COVER DETAILS.
 - b. The standard manhole frame shall meet the requirements set forth on JCW Sheet No. MH05 in SECTION 2531 - JCW MANHOLE RING AND COVER DETAILS.
 - c. The large manhole cover shall meet the requirements set forth on JCW Sheet No. MH03 in SECTION 2531 - JCW MANHOLE RING AND COVER DETAILS.
 - d. The large manhole frame shall meet the requirements set forth on JCW Sheet No. MH06 in SECTION 2531 - JCW MANHOLE RING AND COVER DETAILS.
 - e. The standard bolt-down cover and frame shall meet the requirements set forth on JCW Sheet No. MH01 in SECTION 2531 - JCW MANHOLE RING AND COVER DETAILS.
 - f. All covers shall have two (2) concealed pickholes which meet the requirements set forth on JCW Sheet No. MHA in SECTION 2531 - JCW MANHOLE RING AND COVER DETAILS.
 - g. All covers shall have the sunflower detail integrated into the top surface of the casting. The detail shall meet the requirements set forth on JCW Sheet No. MH04 in SECTION 2531 - JCW MANHOLE RING AND COVER DETAILS.
 - h. The riser ring for the standard manhole frame shall meet the requirements set forth on JCW Sheet No. MH07 in SECTION 2531 - JCW MANHOLE RING AND COVER DETAILS.

- i. The riser ring for the large manhole frame shall meet the requirements set forth on JCW Sheet No. MH08 in SECTION 2531 - JCW MANHOLE RING AND COVER DETAILS.
 2. Test Bars: The manufacturer shall cast and prepare at least three test bars for each lot of castings in accordance with ASTM A48.
- F. Steps:
 1. Steel core, plastic coated steps: Steel core plastic coated steps shall meet the following minimum requirements.
 - a. The plastic coating shall be a copolymer polypropylene meeting ASTM D4101 PP200B33454Z02.
 - b. The steel core shall be a minimum of ½ inch in diameter and grade 60.
- G. Corrosion Protection: Corrosion protection shall be used when specified on the Drawings or Modifications to Detailed Specifications. The Drawings shall specify one of the following systems to be used.
 1. Epoxy Manhole Liner: Following construction, the interior of the manhole or special structure shall be coated per

2. SECTION 2532 - MANHOLE AND STRUCTURE INTERIOR COATINGS. The manhole shall be coated with the epoxy manhole liner from the base to the cone and with the Flexible Epoxy Grade Adjustment and Frame Seal Liner from the cone to the frame.
3. Plastic Liner: The interior of the manhole or special structure shall be constructed with a plastic manhole liner per SECTION 6650 - PLASTIC LINER FOR PROTECTION OF CONCRETE.

PART 3 EXECUTION

3.01. MANHOLE SITE PREPARATION

Manhole site preparation shall be governed by SECTION 2230 - SITE PREPARATION AND EXCAVATION.

3.02. MANHOLE EXCAVATION

- A. General: Excavation for manholes and special structures shall be governed by this Section and SECTION 2230 - SITE PREPARATION AND EXCAVATION. Perform dewatering and chemical soil stabilization or grouting if necessary, due to existing field conditions. It shall be achieved in a suitable and orderly manner providing a minimum disturbance to the general public.
- B. Depth of Excavation: Depth of excavation shall be to that required for proper installation of the manhole or structure. Over-depth excavation may be required by the Engineer if the subgrade is unstable. Over-depth excavation due to unstable subgrade shall be backfilled as required by the Engineer. Over-depth excavation by the Contractor shall be backfilled as required by the Engineer at no additional cost to the Owner.
- C. Side Clearances: Side clearances outside the manhole and/or structures shall be no greater than to allow for forming, connection of piping, installation of joint wraparound sleeves, proper application of special coatings, if required, and to permit inspection. When concrete is to be placed directly against excavated faces, excavation shall be sufficiently outside of the manhole or structure to provide not less than three (3) inches of concrete cover over the steel reinforcement.
- D. Connection to Existing Structures: The excavations necessary for connection to an existing structure shall be performed in a manner so as to avoid damage to the existing structure caused by unbalanced soil pressures.

3.03. MANHOLE OR SPECIAL STRUCTURE INSTALLATION

Manhole or special structure installation shall be governed by this Section and SECTION 2536 - SEWER PIPE INSTALLATION. It shall be performed by the Contractor on a schedule which will provide an orderly progression of the Work.

- A. Bases:

1. Pre-Cast Bases: Pre-cast bases, as described in paragraph 2.01.A.3 above, shall be reinforced in accordance with ASTM C478. Pre-cast bases shall be installed on a maximum of four (4) inches of granular embedment as specified in SECTION 2536 - SEWER PIPE INSTALLATION. Depths exceeding this amount shall be filled with mass concrete.
 2. Cast-In-Place Bases: If pre-cast bases cannot not be used, field poured concrete bases shall be used only with JCW approval. Poured in place bases shall have a minimum thickness of twelve (12) inches. The bottom wall sections shall be embedded in the base section a minimum of five (5) inches. The bottom pre-cast wall section shall not be set upon a previously poured base. Wood shall not be used for supporting or leveling the wall section prior to pouring the base.
- B. Manhole Barrel Sections
1. Inside Dimensions: The minimum horizontal clear distance in the barrel of the manholes shall not be less than four feet unless otherwise specified on the Drawings.
 2. Pre-cast Concrete
 - a. Delivery: Pre-cast concrete components shall not be delivered to the job until representative concrete control cylinders have attained at least 80% of the specified minimum design strength.
 - b. Inspection: Pre-cast concrete shall be inspected when delivered. Rejection of defective or cracked pre-cast concrete components shall be in accordance with ASTM C478.
 - c. Construction: Pre-cast sections shall be cleaned of all dirt, grass, and other deleterious matter. Seal wall and cone joints with a minimum of one bead of preformed butyl joint sealant. Seal the joint between the top adjustment ring and casting with a double bead of preformed butyl joint sealant. Sections shall be placed such that steps are aligned but without rotation or damage to sealant integrity.
 3. Cast-In-Place Concrete
 - a. Install cast-in-place concrete as shown on the Drawings and to the requirements of SECTION 3000 - CAST-IN-PLACE CONCRETE of these specifications.
- C. Top Slabs: Thickness shall conform to the dimensions and reinforcement steel shall be placed as shown on the Drawings.
- D. Pipe Stubs: Stubs shall be installed at the locations, angles, elevations and of the materials as shown on the Drawings. A water-tight removable stopper shall be installed in each pipe stub.

- E. Inverts: Inverts shall be structural concrete and steel-troweled to produce a dense, smooth finish. The invert channel shall be "U" shaped in cross section and extend upward three-fourths of the inside pipe diameter. Smooth transitions shall be formed for pipes of different sizes, elevation and bends. The invert bench shall be sloped to drain. Pre-cast inverts shall not be used.
- F. Steps: Steps shall be aligned vertically below the casting and spaced at sixteen (16) inch centers. The top step shall be not more than one (1) foot below the top of the cone. The lowest step shall be not more than two (2) feet above the invert bench. Field drilled step holes are not permitted in pre-cast concrete manholes.
- G. Top Elevation: The finish top elevation of manhole castings shall conform to the following unless otherwise shown on the Drawings or directed by the Engineer.
 - 1. Paved Areas: In paved or future paved areas, the top of the casting shall conform to the slope of the pavement and be 1/8 inch below the finished pavement elevation.
 - 2. Non-Paved Areas: In non-pavement areas, unless shown otherwise on the Drawings, the top of the casting shall be not more than six (6) inches above the surrounding ground nor less than the sod's upper root limit. The final elevation shall be at a point where water will not pond over the manhole cover.
- H. Riser Rings:
 - 1. Manholes in Pavement: The thickness of the recycled rubber riser rings shall not be less than one (1) inch nor greater than four (4) inches. If the required thickness of riser rings exceeds 4 inches, a 4-inch or 6-inch precast concrete riser ring maybe installed between the rubber riser ring and the cone. The rubber riser rings shall be tapered to match the slope of the existing or proposed pavement at the manhole. The joints between the cone, rubber riser rings, and casting shall be sealed with the manufacturer-supplied sealant.
 - 2. New Manholes Not in Pavement: All new manholes will be provided with riser ring(s) underneath the casting as shown on Drawings. A minimum of one (1) 4-inch riser ring shall be installed on top of the cone section. If a greater depth of adjustment rings is necessary, a combination of 4-inch and 6-inch riser rings may be used up to a maximum of 12 inches of riser rings. If precast concrete riser rings are used, the joints between the cone, riser rings, and casting shall be sealed with a double bead of preformed butyl rubber sealant. If recycled rubber riser rings are used, the joints between the cone, rubber riser rings, and casting shall be sealed with the manufacturer-supplied sealant.
 - 3. Adjustment of an Existing Manhole: If the top of an existing manhole is required to be raised, the combined depth of new riser rings plus the existing riser rings shall not exceed 24 inches. If the required upward adjustment would exceed 24 inches, or if the required downward adjustment is greater than the existing adjustment rings will allow, all vertical adjustments shall be made to the barrel of the manhole.

4. Brick and mortar adjustments will not be allowed.
- I. Castings: Castings shall be installed with the mud ring inserted inside the manhole opening and the flange resting on a minimum of two rows of preformed butyl rubber joint sealant. Bolt down castings shall be held in place as shown on the Standard Drawings.
- J. Joint Sleeves
 1. Butyl Joint Wraparound Sleeves: The sleeves shall be installed according to the following procedure and wrap supplier's recommendations. Wrap width shall be a minimum of six (6) inches. The ends of the wrap shall be overlapped at least twice its width. The wrap shall not be stretched during application. Primer and or adhesive as recommended by the wrap supplier shall be employed on the concrete adjacent to the joint.
 2. Heat Shrinkable Wraparound Sleeves: The sleeves shall be installed according to the following procedure and manufacturer's recommendations. The surface to be covered shall be free of dirt, sharp points, surface rust, and shall be preheated to remove moisture. Apply the primer over all areas to be wrapped and let dry. Cut a length of sleeve twelve inches longer than the exterior circumferential distance around the manhole measured at each joint or manufacturer's recommendation. The wrap shall extend a minimum of six (6) inches above each joint or and a minimum of six (6) inches below each joint on the exterior surface of the manhole. The wrap applied to all wall joints, cone section, and casting shall be a minimum of twelve (12) inches wide. Wrap the sleeve around the manhole. Position the self-adhering closure seal at the overlap. Heat the overlap area and pat down with a gloved hand to ensure bonding. Heat the sleeve until the entire sleeve has recovered. Smooth out the wrinkles. Quench with water or allow the sleeve to cool prior to backfilling for the adhesive to set.
- K. Interior Coatings: Interior coatings shall be applied when noted on the Drawings. Following completion of the manhole or structure, the interior coating shall be applied in accordance with

L. SECTION 2532 - MANHOLE AND STRUCTURE INTERIOR COATINGS.

M. Lift Notches: All lift notches shall be repaired with non-shrink grout. Non-shrink grout shall be in the plastic state with a trowelable mix and show no expansion after set as tested in accordance with ASTM C827. The placement time shall be not less than forty-five (45) minutes based on initial set per ASTM C191.

3.04. MANHOLE BACKFILL

A. No backfill shall be placed over or around any structure until the concrete or mortar has attained a minimum strength of 2000 psi and can sufficiently support the loads imposed by the backfill without damage.

B. The Contractor shall use utmost care to avoid any wedging action between the side of the excavation and the structure that would cause any movement of the structure. Any damage caused by premature or unbalanced backfill or by the use of equipment on or near a structure will be the responsibility of the Contractor.

C. No rock larger than four (4) inches maximum dimension shall be placed within one (1) foot of the exterior surface of any structure.

3.05. RESTORATION

Restoration shall be governed by SECTION 2920 - RESTORATION.

3.06. MANHOLE AND STRUCTURE TESTING AND REPAIR

A. General: Unless approved by JCW, all manholes and other structures shall be tested for infiltration by Method 1 below. Manhole testing shall be performed in the presence of the Engineer and JCW's inspector. Notification by the Contractor to Engineer and JCW shall be as set forth in 3.01 of SECTION 2539 - TESTING LABORATORY SERVICES. The manhole or other structure shall be backfilled prior to testing. All visible leaks shall be repaired by the Contractor prior to retesting and during the warranty period.

- B. Method 1 - Vacuum Infiltration Testing: The pipe plugs shall be installed in the connecting pipes and braced securely to prevent the plugs from being drawn into the manhole. The vacuum test apparatus shall be placed inside or on top of the casting and the seal inflated according to manufacturer's directions as appropriate. A vacuum of 10 inches of mercury shall be drawn and then the vacuum pump shall be shut off. With valves closed, the time shall be measured for the vacuum to drop to 9 inches of mercury. The manhole shall be acceptable if the time for the vacuum to drop from 10 inches to 9 inches is greater than 60 seconds for 4-foot diameter, 75 seconds for 5-foot diameter, 90 seconds for 6-foot diameter manholes, 105 seconds for 7-foot diameter manholes and 120 seconds for 8-foot diameter manholes. If the manhole fails the test, see paragraphs D and E below.
- C. Method 2 - Hydrostatic Infiltration/Exfiltration Testing
1. If allowed by JCW, testing shall be performed using either of the following two methods for new manholes. For existing manholes, only Method 2A shall be used. All lift holes shall be plugged with an approved non-shrink grout prior to testing. All pipes entering the manhole shall be plugged.
 2. Method 2A: The manhole or structure shall be filled to its full depth with water, though water depth shall not exceed 25 feet. Manholes exceeding 25 feet in total depth shall require additional infiltration/exfiltration testing of the upper portion of the manhole as outlined in Method 1A. At least two hours shall be allowed for absorption to take place prior to the start of measurement. Measurement of leakage shall be by measuring the water required to maintain a constant level in the manhole. Measurement shall take place over a 24-hour period unless otherwise directed by JCW for existing manholes where service must be restored. If the manhole fails the test, see paragraphs D and E below.
 3. Method 2B: The upper portion of manholes exceeding 25 feet in total depth shall be dye water tested in the presence of the Engineer and JCW. The dye water testing shall consist of injecting or flooding a concentrated dye solution just outside the manhole frame. The dyed water shall continue to be applied for a minimum of ten (10) minutes after saturation, as evidenced by surface ponding. The manhole will be observed for a minimum period of five (5) minutes after dye water application. Manholes observed to be actively leaking, greater than 1.14 gallons per day per vertical foot, will not be accepted. If the manhole fails the test, see paragraphs D and E below.
- D. Manhole Repair: If the manhole fails the initial testing, repair shall be by pressure grouting or rebuilding the manhole. The grout shall be as specified in paragraph 2.01.D.2 of this Section. Grout holes shall be drill-cleaned and sealed with non-shrink grout. After the grout has cured in accordance with the manufacturer's recommendations, the manhole shall be retested.
- E. Repeated Test Failures: If the manhole fails the test a second time, the Contractor shall disassemble and reassemble the components of the manhole to correct the cause of the leak. If damaged manhole components are found to be the cause of the leak or if manhole components are damaged during

disassembly and reassembly, the Contractor shall replace such damaged components with new.

END OF SECTION 2530

[Back to TOC](#)

SECTION 2531 - JCW MANHOLE RING AND COVER DETAILS
(See Next Page)

NOTES:

1. PROVIDE FOUR (4) EACH 3/4" UNC. x 2" BRASS LID BOLTS.
2. ALL RADIUS DIMENSIONS ARE FOR REFERENCE ONLY.
3. REMOVE ALL SHARP EDGES TO 1/16" RADIUS MINIMUM.
4. SURFACE BETWEEN RING AND COVER SHALL BE MACHINED TO PROVIDE A TRUE PLANE AROUND THE ENTIRE HORIZONTAL BEARING AREA OF THE RING AND COVER.

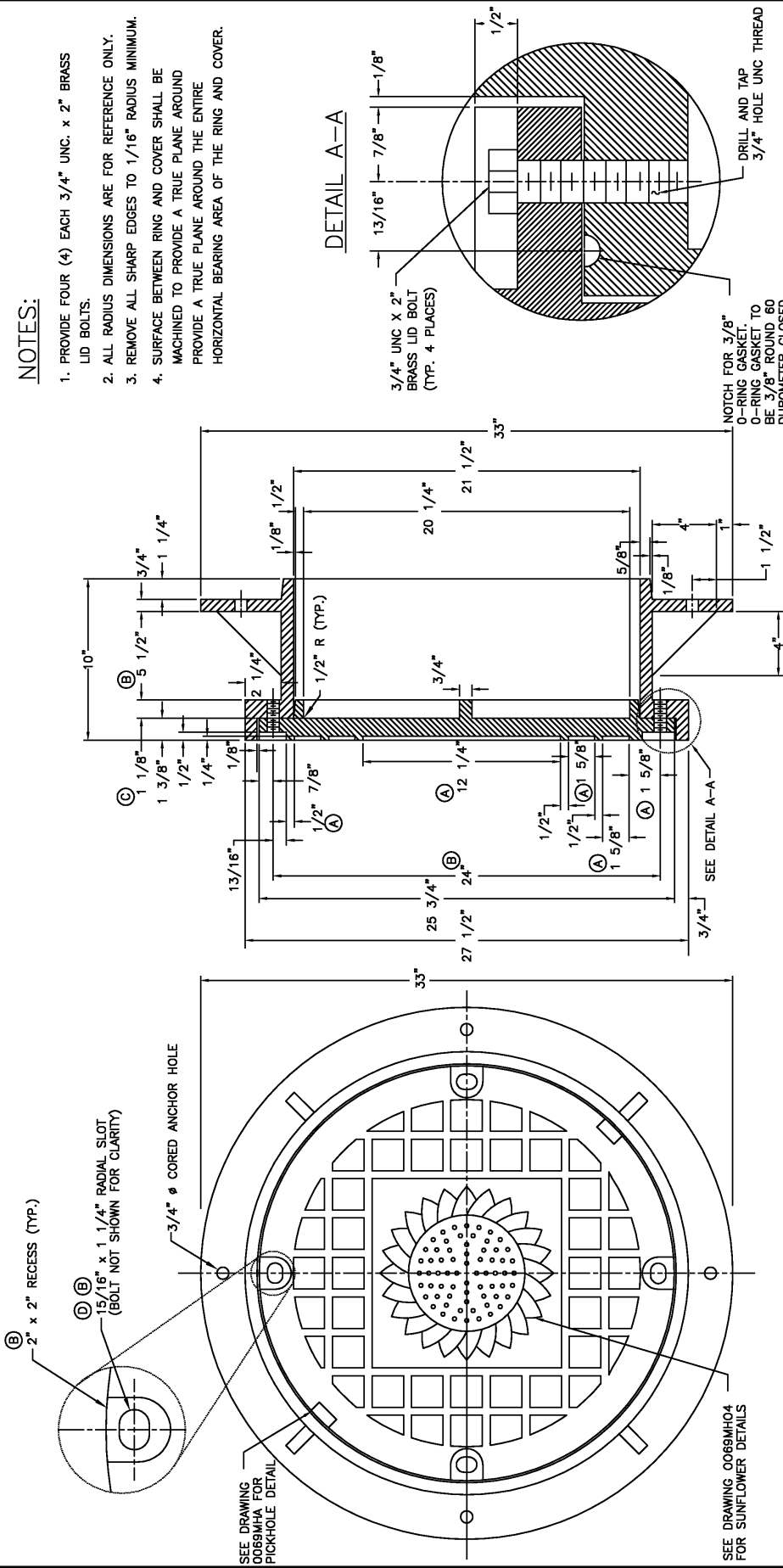

Johnson County
Unified Wastewater Districts
10881 Lowell, Suite 100
Overland Park, Ks. 66210

Drawn	JJ JONES	Date	9/91	Scale	NTS
Checked		Date		Project #	0069
Approved		Date		Sheet	MH01
Title PLAN, SECTION AND DETAIL VIEWS					
Project BOLT DOWN FRAME AND MANHOLE COVER					

NO.	BY	DATE	REVISION
G	JD	4/96	REVISION
F	DH	7/91	ANSI NOTE ADDED
E	JJ	9/91	ACAD CONVERSION
D	SG	8/87	REVISION
C	SG	6/87	REVISION
B	SG	1/87	REVISION
A	GW	1/86	REVISION

(E) ALL BOLTS SHALL COMPLY TO THE ANSI BOLT STANDARDS OF B18.21-1981

MATERIALS TO MEET SPECIFICATIONS FOR GREY IRON CASTINGS A.S.T.M. A-48, CLASS 30 AS A MINIMUM REQUIREMENT.

SEE DRAWING 0069MH04 FOR SUNFLOWER DETAILS

SEE DRAWING 0069MHA FOR PICK-HOLE DETAIL

SEE DETAIL A-A

NOTCH FOR 3/8" O-RING GASKET. O-RING GASKET TO BE 3/8" ROUND 60 DUROMETER CLOSED CELL NEOPRENE.

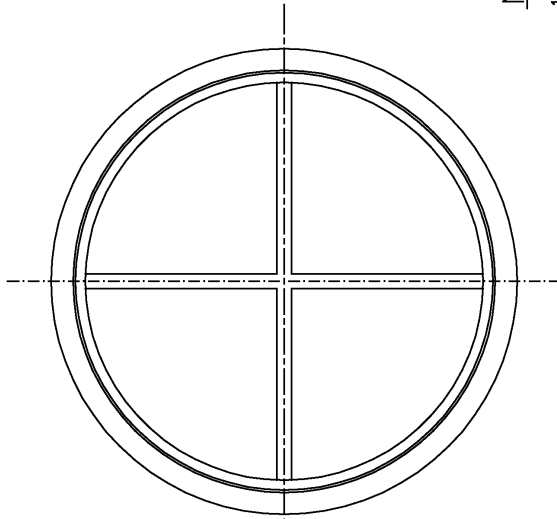

SEE DRAWING 0069MHA
FOR PICKHOLE DETAIL
SEE DRAWING 0069MH04
FOR SUNFLOWER DETAIL

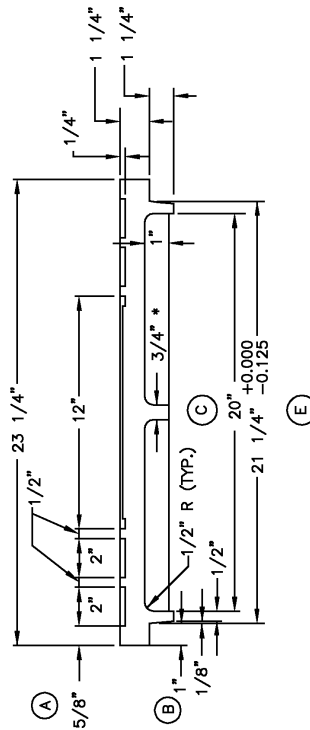

* 1/8" MAXIMUM TAPER MAY BE UTILIZED ON RIBS
AND GUSSETS TO FACILITATE CASTING.

MATERIALS TO MEET SPECIFICATIONS FOR
GREY IRON CASTINGS A.S.T.M. A-48,
CLASS 30 AS A MINIMUM REQUIREMENT.

NOTES:

1. ALL RADIUS DIMENSIONS ARE FOR REFERENCE ONLY.
2. REMOVE ALL SHARP EDGES TO 1/16" RADIUS MINIMUM.
3. SURFACE BETWEEN RING AND COVER SHALL BE MACHINED TO PROVIDE A TRUE PLANE AROUND THE ENTIRE HORIZONTAL BEARING AREA OF THE RING AND COVER.



Johnson County
Unified Wastewater Districts
10881 Lowell Suite 100
Overland Park, Kansas 66210

Drawn	G. WARD	Date	8/86	Scale	NTS
Checked	WILLIAM CARTER	Date	8/86	Project #	0069
Approved	JOHN METZLER	Date	8/86	Sheet	MH02
Title PLAN AND SECTION VIEWS					
Project STANDARD MANHOLE COVER					

E	JD	4/96	REVISION
D	JJ	7/91	ACAD CONVERSION
C	DH	7/90	WAS 20 1/2"
B	DH	7/90	WAS 3/4"
A	GW	11/86	REVISION
NO	BY	DATE	REVISION

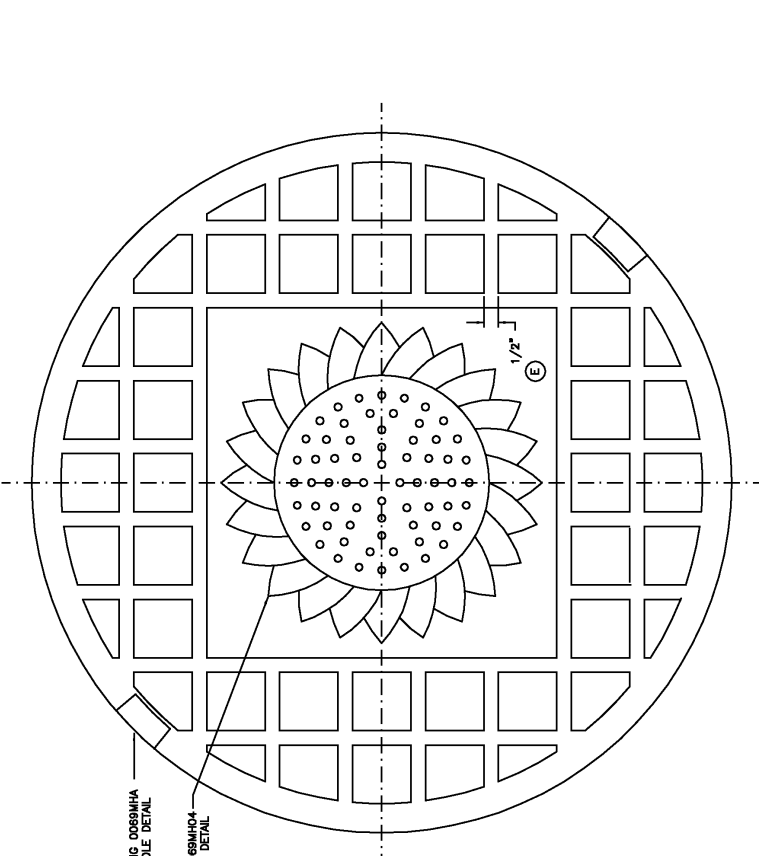
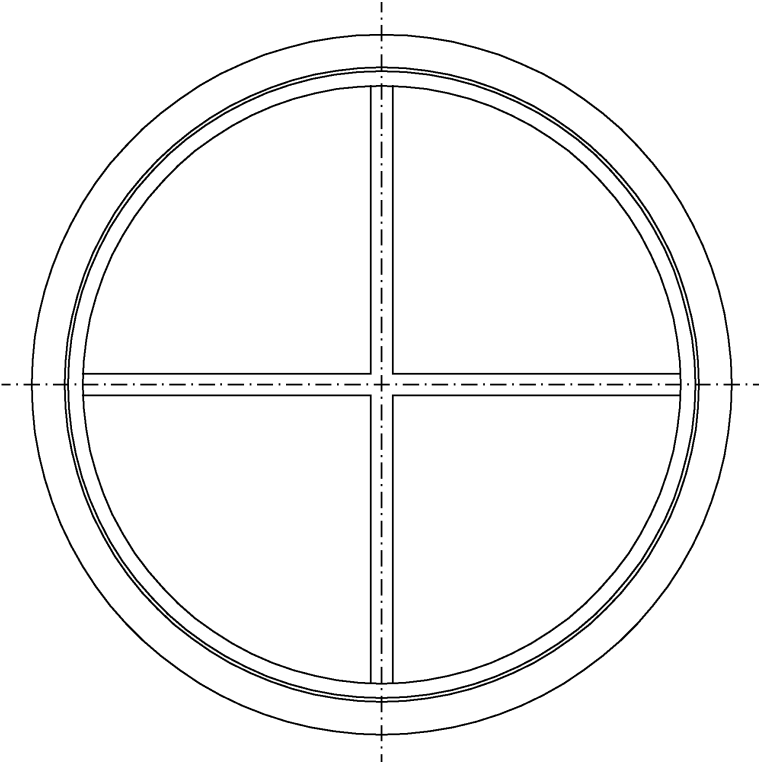

SEE DRAWING O063M04
FOR PICKHOLE DETAIL

SEE DRAWING O063M04
FOR SUNFLOWER DETAIL

MATERIALS TO MEET SPECIFICATIONS FOR
GREY IRON CASTINGS A.S.T.M. A-48,
CLASS 30 AS A MINIMUM REQUIREMENT.

NOTES:

1. ALL RADIUS DIMENSIONS ARE FOR REFERENCE ONLY.
2. REMOVE ALL SHARP EDGES TO 1/16" RADIUS MINIMUM.
3. SURFACES BETWEEN RING AND COVER SHALL BE MACHINED TO PROVIDE A TRUE PLANE AROUND THE ENTIRE HORIZONTAL BEARING AREA OF THE RING AND COVER.

E	JD	4/96	REVISION
D	HK	3/90	WAS 1"
C	HK	3/90	WAS 22"
B	HK	3/90	WAS 20 3/4"
A	HK	3/90	ACAD CONVERSION
	NO.	BY	DATE

* 1/8" MAXIMUM TAPER MAY BE UTILIZED ON RIBS
AND GUSSETS TO FACILITATE CASTING.



Johnson County
Unified Wastewater Districts
10881 Lowell, Suite 100
Overland Park, Kansas 66210

Drawn	GV	Date	8/1/86	Scale	NTS
Checked	WCC	Date	8/1/86	Project #	0069
Approved	JAM	Date	8/1/86	Sheet	MH03

Title: PLAN AND SECTION VIEWS
Project: LARGE MANHOLE COVER

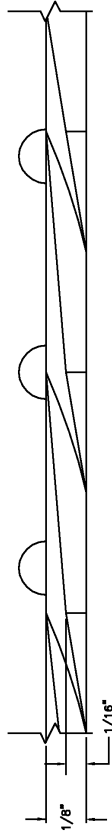
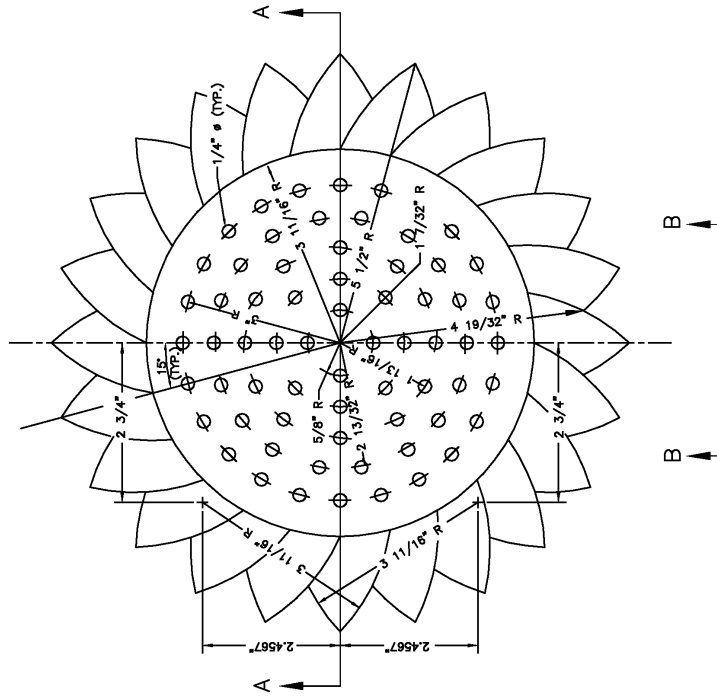

VIEW B-B

NOTES:

1. ALL RADIUS DIMENSIONS ARE FOR REFERENCE ONLY.
2. REMOVE ALL SHARP EDGES TO 1/16" RADIUS MINIMUM.
3. ALL SEED KNOBS TO BE POSITIONED RADIIALLY ON THE FLOWER FACE WITH THE FOLLOWING NUMBER OF SEEDS ON EACH ROW.
 ROW 1 4 SEEDS
 ROW 2 8 SEEDS
 ROW 3 12 SEEDS
 ROW 4 18 SEEDS
 ROW 5 24 SEEDS
4. MATERIALS TO MEET SPECIFICATIONS FOR GREY IRON CASTINGS A.S.T.M. A-48, CLASS 30 AS A MINIMUM REQUIREMENT.

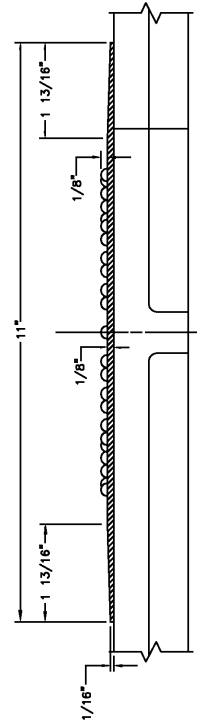

SECTION A - A

Johnson County
 Unified Wastewater Districts
 10881 Lowell Suite 100
 Overland Park, Kansas 66210

Drawn	G. WARD	Date	8/86	Scale	NIS
Checked	WILLIAM CARTER	Date	8/86	Project #	0069
Approved	JAM	Date	8/86	Sheet	MH04

Title		PLAN AND SECTION VIEWS
Project		MANHOLE COVER SUNFLOWER DETAIL

B	JD	4/96	REVISION
A	LJ	7/91	ACAD CONVERSION
No.	BY	DATE	REVISION

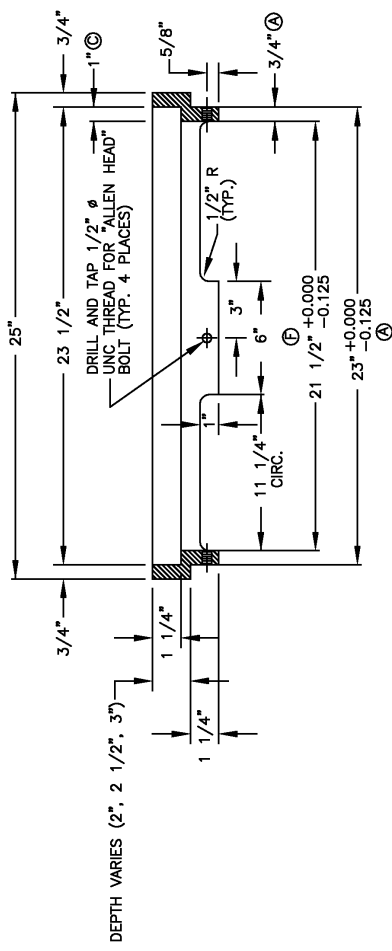

NOTES:

1. PROVIDE FOUR (4) 1/2" ϕ x 3/4" \odot UNC CONICAL END ALLEN HEAD BOLTS. \textcircled{B}
2. ALL RADIUS DIMENSIONS ARE FOR REFERENCE ONLY.
3. REMOVE ALL SHARP EDGES TO 1/16" RADIUS MINIMUM.
4. SURFACE BETWEEN RING AND COVER SHALL BE MACHINED TO PROVIDE A TRUE PLANE AROUND THE ENTIRE HORIZONTAL BEARING AREA OF THE RING AND COVER.
5. ALLEN HEAD BOLTS SHALL COMPLY TO SET SCREW ANSI STANDARDS OF B18.2 - 1986.

MATERIALS TO MEET SPECIFICATIONS FOR GREY IRON CASTINGS A.S.T.M. A-48, CLASS 30 AS A MINIMUM REQUIREMENT.

		Johnson County Unified Wastewater Districts 10881 Lowell, Suite 100 Overland Park, Kansas 66210	
Drawn	JJ JONES	Date	8/91
Checked		Date	
Approved		Date	
Title		PLAN AND SECTION VIEWS	
Project		STANDARD MANHOLE RISER RING	
Scale	NTS	Project #	0069
Sheet	MH07		

F. JD.	4/96	REVISION
E. JJ.	8/91	ACAD. CONVERSION
D. DH.	7/91	DIMENSION WAS 1"
C. RA.	8/89	DIMENSION CHANGED
B. GW.	6/89	CHANGED TO CONICAL END
A. GW.	7/88	DIMENSIONS CHANGED
NO.	BY	DATE

JOHNSON COUNTY UNIFIED WASTEWATER DISTRICTS APPROVED CONCEALED PICKHOLE DESIGN

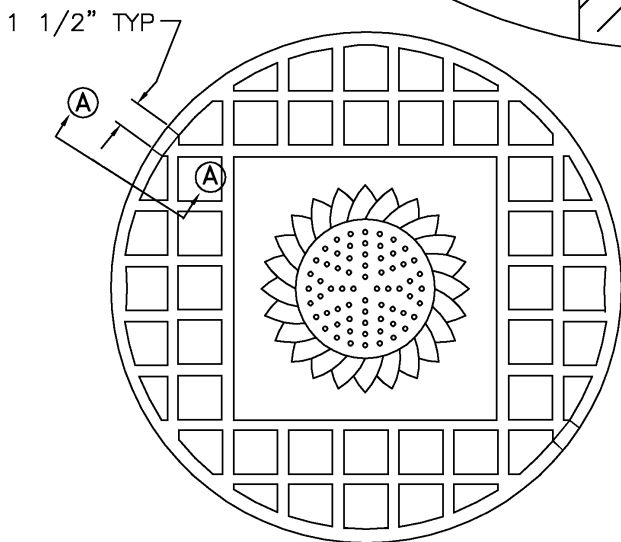
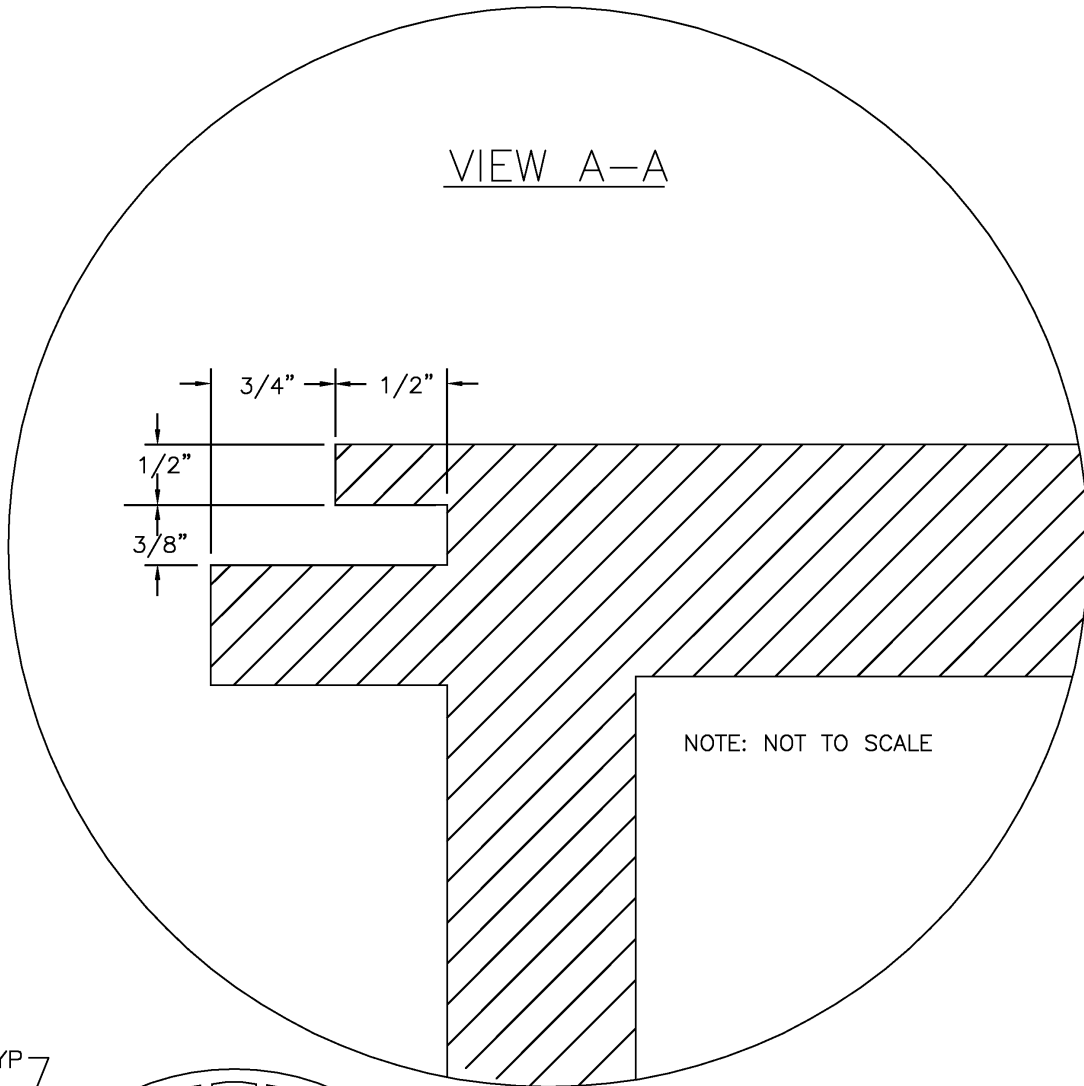

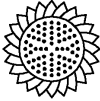
 Johnson County Unified Wastewater Districts 10881 Lowell, Suite 100 Overland Park, KS 66210			
Drawn	G. WARD	Date	8/1/86
Scale	NO SCALE		
Checked	WILLIAM CARTER	Date	8/86
Project #	0069		
Approved	JOHN METZLER	Date	8/86
Sheet	MHA		
Title	CASTING DETAILS		
CONCEALED PICKHOLE DESIGN			

A	JJ	7/91	ACAD CONVERSION	
NO.	BY	DATE		REVISION

SECTION 2532 - MANHOLE AND STRUCTURE INTERIOR COATINGS

PART 1 GENERAL

1.01. WORK INCLUDED IN THIS SECTION

This section governs the furnishing of all labor, equipment, tools, and materials, and the performance of all work incidental to the rehabilitation/lining of manholes and special sewer structures including cleaning the entire interior surface of the structure and preparation (plugging/patching) of the concrete structure's interior surface for lining.

1.02. SPECIFICATION MODIFICATIONS

It is understood that throughout this section these Specifications may be modified by appropriate items in the Modifications to Detailed Specifications or notes on the Contract Drawings.

1.03. REVISIONS OF STANDARDS

When reference is made to a Standard Specification i.e. ASTM, ANSI, AWWA, MCIB, the Specification referred to shall be understood to mean the latest revision of said specification as amended at the time of the Notice to Bidders, except as noted on the Drawings or in the Modifications to Detailed Specifications.

1.04. SUBMITTALS

The Contractor shall provide certifications or shop drawings on all materials provided under these specifications in accordance with the General Requirements.

1.05. QUALIFICATIONS

- A. The Contractor shall be certified by the manufacturer of the particular coating/lining that said company is a fully trained user of the application equipment. Personnel directly involved shall receive training in the proper methods for handling and installing the lining/coating. Training shall be performed by qualified representative. Copies of the certificates provided by the manufacturer to the Contractor and installation personnel shall be provided to JCW.
- B. The contractor and the contractor's staff shall have experience installing cementitious liner and epoxy liner, with a minimum installation of 15,000 vertical feet of cementitious liner and 15,000 vertical feet of epoxy liner.

PART 2 PRODUCTS

2.01. INTERIOR LINER

The internal surface of a manhole shall be coated, as noted on the Drawings, with one of the following.

- A. Cementitious Liner: Manhole liners under this part shall apply to eliminating infiltration, providing corrosion protection, repair of voids, and restoration of the structural integrity of the substrate. The materials, mixing ratios, and procedures utilized for the lining process shall be in accordance with the manufacturer's

recommendations. The applicator shall be approved and trained by the manufacturer of the lining system materials. The product shall be manufactured by Strong-Seal Systems, Corp., Pine Bluff, Arkansas; Quadex Inc., North Little Rock, Arkansas; or approved equal.

1. Patching Material

a. A quick setting corrosion resistant cementitious material shall be used as a patching material, and is to be mixed and applied according to manufacturer's recommendations, and shall have the following minimum requirements:

- i. Compressive Strength: ASTM C579B, 1,400 psi, 6 hrs.
- ii. Bond: ASTM C321, 1,000 psi, 24 hrs.
- iii. Applied Density: 120 lbs \pm 5 lbs pcf
- iv. Shrinkage: ASTM C157, 0% at 90% R.H.

2. Infiltration Control Material

a. A rapid setting cementitious product, specifically formulated for leak control, shall be used to stop minor water infiltration, shall be mixed and applied according to manufacturer's recommendations and shall have the following minimum requirements:

- i. Compressive Strength: ASTM C579B, 600 psi, 1 hr., 1,000 psi, 24 hrs.
- ii. Bond: ASTM C321, 30 psi, 1hr., 80 psi, 24 hrs.

3. Grouting Material

a. A cementitious grout shall be used for stopping very active infiltration and filling voids, and shall be mixed and applied according to manufacturer's recommendations. The cementitious grout shall be volume stable, and have a minimum twenty-eight (28) day compressive strength of 250 psi and a one (1) day compressive strength of 50 psi.

b. A cementitious grout designed for special soil conditions, and shall be used per manufacturer's recommendations. The cementitious grout shall be volume stable, and have a minimum twenty-eight (28) day compressive strength of 1,000 psi.

c. Chemical grouts may be used for stopping very active infiltration and shall be mixed and applied per manufacturer's recommendations.

4. Liner Material

- a. A cementitious product shall be used to form a structural/structurally enhanced monolithic liner covering all interior substrate surfaces. The liner material shall be applied with machinery specially designed for the application, and shall have the following minimum requirements at twenty-eight (28) days:
 - i. Compressive Strength: ASTM C495, >3,000 psi
 - ii. Tensile Strength: ASTM C496, >300 psi
 - iii. Flexural Strength: ASTM C293, >600 psi
 - iv. Shrinkage @ 90% R.H.: ASTM C596, 0%
 - v. Bond: ASTM C321, >130 psi
 - vi. Density, when applied: 105 pcf
- b. Liner material shall be one of the following products:
 - i. Strong-Seal ® MS-2A shall be made with Type I or Type III Portland Cement and shall be used according to manufacturer's recommendations in applications where there is no, or very mild, sulfide conditions (pH 3.0 or higher).
 - ii. Strong-Seal ® MS-2C or Quadex Aluminaliner shall be made with Calcium Aluminate Cement and shall be used according to manufacturer's recommendations in applications where there is evidence of severe sulfide conditions (pH 2.0 or higher).
 - iii. Strong-Seal ® Sewpercoat ® PG or Quadex Approved Equal shall be used in applications where harsh hydrogen sulfide conditions regardless of surface pH, as long as environment is in a municipal sanitary system.

B. Epoxy Liner: The epoxy manhole liner shall be chemical resistant (below a pH of 2.0), VOC compliant, moisture tolerant, 100% solids, two (2) component epoxy system with the following properties:

Flexural Strength [ASTM D790]:	> 10,000 psi
Compressive Strength [ASTM D695]:	> 10,000 psi
Tensile Strength [ASTM D638]:	> 7,000 psi
Adhesion:	Concrete Substrate Failure
Abrasion Resistance [Tabor Coefficient, ASTM D4060]:	< 95 mg loss

- C. Flexible Epoxy Grade Adjustment and Frame Seal Liner: The flexible epoxy grade adjustment and frame seal liner shall be 100% solids, solvent free, chemical resistant, VOC compliant, moisture tolerant, two (2) component flexible epoxy coating system with the following properties:

Tensile Strength [ASTM D638]:	> 1,500 psi
Tensile Ultimate Elongation [ASTM D638]:	200%
Hardness, Shore D [ASTM D2240]:	65
Adhesion [ASTM 4541, 10-12 mils DFT]	
Steel (SSPC-10):	> 930 psi
Concrete:	Concrete Substrate Failure
Temperature Resistance [Steel unprimed and concrete]:	200°F
Initial Tear Resistance [ASTM D1004]:	330lbs/in
Tear Strength [ASTM D624]:	225lbs/in
Abrasion Resistance [Tabor Coefficient, ASTM D4060]:	< 50 mg loss

PART 3 EXECUTION

3.01. CEMENTITIOUS LINER

Repair of existing manholes by installing a cementitious lining shall consist of: 1) cleaning the entire manhole interior surface; 2) removal of any existing steps; 3) preparation (plugging/patching) of the manhole interior surface for lining including repair of frame seal, grade adjustment, cone/wall joint, pipe seals and bench and invert as required to prepare manhole for lining; and 4) lining the entire manhole interior surface with a structural/structurally enhanced monolithic liner.

- A. Cleaning: Prior to cleaning, covers shall be placed over the flow channels to prevent extraneous material from entering the sewer lines. Cleaning shall consist of completely removing loose bricks and mortar, unsound concrete, bricks, grease, roots, mud and debris from the interior surface of the manhole to a depth necessary to expose a sound sub-base. All roots shall be cut flush with the manhole wall. The entire interior surface of the manhole shall be cleaned using a high pressure (minimum of 2,000 psi) water (potable) spray.
- B. Preparation for Manhole Lining
 - 1. After cleaning, the manhole interior surface shall be prepared for lining. Loose or missing brick shall be removed and replaced, actively leaking areas plugged, and voids patched. Any patching and/or plugging materials shall be deemed compatible with the lining material used for lining the manhole as determined by the manufacturers.
 - 2. The manufacturer of the cementitious liner shall provide the Contractor recommendations for methods and materials to plug actively leaking areas. Holes (including holes left after removing steps), voids, and cracks shall be patched with cement patch conforming to the manufacturer's

instructions. Contractor shall follow all manufacturer instructions during the course of the Work.

3. Prior to lining brick manholes, the stair stepped brick surface on the underside of the cones shall be filled in with cementitious liner to create a uniform sloped surface on which to apply the cementitious liner.
4. Any bench, invert, pipe seal with roots, visible damage and/or extraneous water leakage shall be repaired prior to installation of cementitious liner.

C. Manhole Sealing - Cement Manhole Liner

1. Application (spraying) of the lining material shall be done in accordance with the manufacturer's recommendations. The entire manhole interior surface shall be clean and free of foreign material, and damp without noticeable free water droplets or running water, but totally saturated. The manhole bench and invert shall be covered with plywood, and the material spray applied from the bottom of the wall to the top of the manhole to form a coating of uniform thickness sufficient to insure that all cracks, crevices, and voids are filled and a relatively smooth hand troweled surface remains.
 2. The thickness of the lining material shall not be less than one (1") inch thick at any point from the wall/bench joint to the bottom of the frame.
 3. After application of the manhole lining material, the plywood covers shall be removed from the flow channels and the bench sprayed in such a manner to produce a bench having a gradual slope from the wall/bench intersection to the edge of the rim of the trough (flow channel). Material at the wall/bench intersection shall be built up and rounded to produce a uniform radius at the circumference of the intersection.
 4. The thickness of lining material shall be no less than 1-inch on the bench at the rim of the trough, and shall increase in the direction of the wall to provide the required slope as shown on the Standard Details.
- D. Equipment: Equipment used to mix and apply the lining material shall meet the requirements and specifications of the manufacturer.
- E. Mixing: Mixing of the lining material shall be done in accordance with requirements and specifications of the manufacturer.
- F. Curing: Curing of the applied lining material shall be done in accordance with the manufacturer's recommendations. Sufficient cure time shall be provided prior to subjecting the applied liner to active flow. Traffic shall not be allowed over substrates until sufficient cure time has elapsed.
- G. Weather: No application shall be made to frozen surfaces, or if freezing is expected to occur inside the substrate within 24 hours after the application. Specific recommendations and field methods approved by the manufacturer shall be followed for applying lining material when ambient temperatures are less than 45° F or in excess of 95° F.

- H. Product Testing: Four (4) 2-inch cubes shall be cast each day, or from every 50 bags of product used, and shall be properly labeled and sent to the manufacturer for testing in accordance with the manufacturer's directions, for compressive strength testing as described in ASTM C109.

3.02. EPOXY MANHOLE LINER

Installation of epoxy liner shall consist of: cleaning the entire interior surface of the structure; preparation (plugging/patching) of the concrete structure's interior surface for lining; installation of the cementitious liner, where required to create a smooth surface for installation of the epoxy liner; and lining the concrete structure's interior surface with a single coat of a two component, 100% solids epoxy coating system which provides a durable, high strength, monolithic lining, at an average thickness of 175 mils with a minimum thickness of 165 mils.

- A. Cleaning: Prior to cleaning, covers shall be placed over the flow channels to prevent extraneous material from entering the flow stream. Cleaning shall consist of completely removing loose materials, unsound concrete, grease, mud and debris from the interior surface of the structure to a depth necessary to expose a sound subbase. Remove dust, laitance, grease, paint, form release agents or any other surface contaminants using a power washer as defined herein. Patching/plugging manhole defects as necessary to provide a smooth surface for application of the epoxy liner. The entire interior surface of the structure shall be cleaned using a high pressure (minimum of 3000 psi) water (potable) spray.
- B. Preparation of Concrete for Lining: After cleaning, the interior surface shall be prepared for lining. Loose or missing material shall be removed and replaced, actively leaking areas plugged, and voids patched. Any patching and/or plugging materials shall be deemed compatible with the lining material used for lining the manhole as determined by the manufacturers.
 - 1. Brick Manholes: Prior to epoxy lining brick manholes, the stair stepped brick surface on the underside of the cones shall be filled in with cementitious liner to create a uniform sloped surface on which to apply the epoxy liner.
- C. Equipment: Provide mixing and application equipment designed for mixing and spraying epoxy coating as recommended by the manufacturer.
- D. Mixing: The two (2) part epoxy liner shall be mixed in accordance with the manufacturer's recommendations.
- E. Application: The epoxy liner shall be applied in accordance with the manufacturer's recommendations. The surface prior to application may be damp but shall not have noticeable free running water. Materials shall be spray applied in one coating to an average thickness of 175 mils with a minimum thickness of 165 mils. The final application shall have a minimum of four (4) hours cure time before being subjected to active flow. The epoxy liner shall be applied over the entire interior surface of the structure with the exception of the trough (flow channel).

- F. Curing: Curing of the applied lining material shall be done in accordance with the manufacturer's recommendations. Sufficient cure time shall be provided prior to subjecting the applied liner to active flow.
- G. Weather: No application shall be made to frozen surfaces, or if freezing is expected to occur inside the substrate within 24 hours after the application. Specific recommendations and field methods approved by the manufacturer shall be followed for applying lining material when ambient temperatures are less than 45°F or in excess of 95°F.
- H. Quality Control and Inspection: During the application, a wet film gauge shall be used regularly to insure that minimum thickness is being maintained. After the epoxy liner has set (hard to touch) all visible pinholes shall be repaired. Repairs shall be made by lightly abrading the surface and brushing the lining material over the area. All blisters and evidence of uneven coverage shall be repaired according to the manufacturer's recommendations. After the product has set to touch, the surface shall be inspected for pinholes and thin spots using a Holiday Detector capable of 16,000 volts. The minimum voltage utilized during this "Holiday Testing" shall be 50 volts per mil of coating thickness or a minimum of 12,500 volts. Pinholes and areas less than one square foot that test to be thin may be retouched by hand, but any areas larger than one square foot must be re-sprayed. Retouching and re-spraying shall be performed according to the manufacturer's requirements.
- I. After testing the area from six inches (6") below the top of the cone to the top of the frame shall be coated with the flexible epoxy grade adjustment and frame seal liner material identified in Paragraph 3.03 of this Section.

3.03. FLEXIBLE EPOXY GRADE ADJUSTMENT AND FRAME SEAL LINER

Installation of the flexible epoxy grade adjustment and frame seal liner shall consist of cleaning the interior surface of the manhole frame and cover; lining the interior of the manhole with the two component, 100% solids epoxy coating system which provides a durable, high strength, monolithic lining, at an average thickness of 250 mils with a minimum thickness of 245 mils from six (6") inches below the top of the cone section to the top of the frame.

A. Cleaning

- 1. Cleaning shall consist of completely removing dirt, debris, grease or other surface contaminants from the surface of the epoxy manhole liner from the top of the cone to the top of the frame. Remove any dust, laitance, grease, paint, rust, scale or any other surface contaminants from the interior surfaces of the adjustment ring(s) and the frame and cover as defined herein. The entire interior surface of the frame and cover shall be prepared according to SSPC-SP6 "Commercial Blast Cleaning." An alternative method of cleaning maybe the use of a high pressure (greater than 5000 psi) water (potable) spray or water with sand injections. The anchor profile for surface preparation shall be a minimum of 2 mils. All excess butyl joint sealant shall be removed prior to the installation of the flexible epoxy coating material.

2. To facilitate bonding between the two epoxy materials, the previously installed epoxy liner material identified in Paragraph 3.01 of this Section shall be abraded with an 80-grit wheel from six inches (6") below the top of the cone to the top of the cone before the application of the flexible epoxy grade adjustment and frame seal liner material. If the flexible epoxy coating is installed within 24 hours of the installation of the epoxy manhole liner material identified in Paragraph 3.01 of this Section, it is not necessary to abrade the surface of the previously applied epoxy.
- B. Equipment: Provide mixing and application equipment designed for mixing and applying the flexible epoxy material as recommended by the manufacturer.
 - C. Mixing: The two (2) part epoxy liner shall be mixed in accordance with the manufacturer's recommendations.
 - D. Application: After the adjustment ring(s), frame seal, and frame have been cleaned and prepared, the flexible epoxy coating shall be installed from six inches (6") below the top of the cone section to the lip of the bearing surface of the frame. The surface prior to application shall be moisture and contaminant free. Materials shall be hand or sprayed applied per manufacturer's recommendations to an average thickness of 250 mils with a minimum thickness of 245 mils. The final application shall have a minimum of twenty-four (24) hours cure time before being subjected to personnel access or surface loading.
 - E. Curing: Curing of the applied lining material shall be done in accordance with the manufacturer's recommendations. Sufficient cure time shall be provided prior to subjecting the applied liner to active flow. Traffic shall not be allowed over substrates until sufficient cure time has elapsed.
 - F. Weather: No application shall be made to frozen surfaces, or if freezing is expected to occur inside the substrate within 24 hours after the application. Specific recommendations and field methods approved by the manufacturer shall be followed for applying lining material when ambient temperatures are less than 45° F or in excess of 95° F.
 - G. Quality Control and Inspection: During the application, a wet film gauge shall be used regularly to insure that minimum thickness is being maintained. After the epoxy liner has set (hard to the touch), all visible pinholes shall be repaired. Repairs shall be made by lightly abrading the surface and brushing the lining material over the area. All blisters and evidence of uneven coverage shall be repaired according to the manufacturer's recommendations. After the product has set to touch, the surface shall be inspected for pinholes and thin spots using a Holiday Detector capable of 16,000 volts. The minimum voltage utilized during this "Holiday Testing" shall be 50 volts per mil of coating thickness or a minimum of 12,500 volts. Pinholes and areas less than one square foot that test to be thin may be retouched by hand, but any areas larger than one square foot must be re-sprayed. Retouching and re-spraying shall be performed according to the manufacturer's requirements.

END OF SECTION 2532

SECTION 2534 - SANITARY SEWER PIPE

PART 1 GENERAL

1.01. WORK INCLUDED IN THIS SECTION

This section governs materials required to complete pipeline construction, exclusive of structures, as shown on the Drawings.

1.02. SPECIFICATION MODIFICATIONS

It is understood that throughout this section these Specifications may be modified by appropriate items in the Modifications to Detailed Specifications or notes on the Contract Drawings.

1.03. REVISIONS OF STANDARDS

When reference is made to a Standard Specification i.e. ASTM, ANSI, AWWA, MCIB, the Specification referred to shall be understood to mean the latest revision of said specification as amended at the time of the Notice to Bidders, except as noted on the Drawings or in the Modifications to Detailed Specifications.

1.04. SUBMITTALS

The Contractor shall provide certifications or shop drawings on all materials provided under these specifications in accordance with the General Requirements.

PART 2 PRODUCTS

2.01. GENERAL

- A. Requirements: Furnish pipe of materials, joint types, sizes, and strength classes indicated and specified. Higher strengths may be furnished at the Contractor's option at no additional cost to the Owner.
- B. Manufacturer: The manufacturer shall be experienced in the design, manufacture and commercial supplying of the specific material.
- C. Inspection and Testing: Inspection and testing shall be performed by the manufacturer's quality control personnel in conformance with applicable standards. Testing may be witnessed by JCW, Engineer, or approved independent testing laboratory. The Contractor shall provide three (3) copies of certified test reports indicating that material does conform to the specifications.
- D. Delivery, Storage and Handling: The manufacturer and Contractor shall use equipment and methods adequate to protect the pipe, joint elements and prevent shock contact of adjacent units during moving or storage. Damaged sections that cause reasonable doubt as to their structural strength or water-tightness will be rejected.
- E. Pipe Manufacturer's Field Services: If noted on the Drawings or stated in the Modifications to Detailed Specifications, the following requirements shall apply:

1. An experienced, competent, and authorized field service representative shall be provided by the pipe manufacturer to perform all pipe manufacturer's field services specified herein. The field service representative's minimum required experience qualifications shall include 5 years of practical knowledge and experience installing the pipe with joints, lining, and coating of the pipe to be provided. The pipe manufacturer's field service representative shall be acceptable to JCW. A resume of the proposed pipe manufacturer's field service representative shall be submitted for review. The resume shall include the field service representative's experience record which meets the specified minimum required experience qualifications.
 2. All pipe shall be installed in accordance with the pipe manufacturer's recommendations and approval of Engineer. The pipe manufacturer's field service representative shall visit the site and inspect, check, instruct, guide, and direct Contractor's procedures for pipe handling, laying, and jointing at the start of pipe installation for each crew. The pipe manufacturer's field service representative shall coordinate his services with Contractor.
 3. Each joint, including restrained joints, shall be checked by Contractor as instructed by the pipe manufacturer's field service representative to determine that the joint and the restraints are installed properly.
 4. The pipe manufacturer's field service representative shall furnish to JCW through Contractor and Engineer, a written report certifying that Contractor's installation personnel have been properly instructed and have demonstrated the proper pipe handling and installation procedures. The pipe manufacturer's field service representative shall also furnish to JCW, through Contractor and Engineer, a written report of each site visit. The pipe manufacturer's field service representative shall revisit the site as often as necessary to perform an installation check.
 5. All costs for these services shall be included in the Contract Price.
- F. Emergency Repair Manual: If noted on the Drawings or stated in the Modifications to Detailed Specifications, the Contractor shall submit an emergency repair manual prepared and furnished by the pipe manufacturer. The emergency repair manual shall include procedures for handling emergency calls and repairs; a list of stock replacement pipe sections, closures, and other parts needed for emergency repairs; names and emergency telephone numbers of pipe manufacturer's engineering staff and factory-trained field service representatives who can be contacted day or night during an emergency; response and delivery times; and installation instructions for the materials and methods used in making repairs. The pipe manufacturer shall provide emergency assistance that may be required at no additional cost to the Owner.
- G. Tunneling and Boring: The allowable materials for carrier pipes in tunnels and bores are listed in SECTION 2410 - TUNNELING and SECTION 2445 - BORING, respectively.

2.02. SEWER MAIN MATERIALS

Pipes, Fittings, Joints, Coatings and Linings

- A. General: Furnish pipe and fittings of materials, joint types, sizes, coatings and linings as indicated and specified herein. Unless indicated on the Drawings, the pipe strength classes shall be as specified herein.
- B. Ductile-Iron Pipe and Fittings: Pipe and fittings shall conform to ANSI/AWWA C151/A21.51, ANSI/AWWA C110/A21.10, and ANSI/AWWA C153/A21.53 except as otherwise specified herein.
 - 1. General: Furnish maximum pipe lengths normally produced by the manufacturer except for fittings, closures and specials.
 - 2. Design: All ductile iron pipe shall meet the requirements of ANSI/AWWA C 150/A21.50 and ANSI/AWWA C 151/A21.51 and shall be of the thickness class specified herein or shown on the Drawings. The minimum thicknesses allowed are Special Class 50 and 51. If Standard Pressure Classes pipe is provided, the thickness of the pipe shall equal or exceed the wall thickness of a Special Class 50 and 51, except as shown on the Drawings.
 - 3. Joints
 - a. Mechanical: Mechanical and push-on joints for pipe and fittings shall conform to the requirements of ANSI/AWWA C111/A21.11.
 - b. Flanged: Flanged joints for ductile iron pipe and fittings shall conform to the requirements of ANSI/AWWA C115/A21.15. The minimum thicknesses allowed for flanged pipe shall be Special Class 53.
 - c. Gaskets: Gaskets shall be neoprene or other synthetic rubber material, except when the gasket is anticipated to come in contact with petroleum based products in which case oil-resistant Nitrile (Buna-N) gaskets shall be used. Natural rubber gaskets will not be acceptable.
 - d. Restraining Systems: All pipe shown on the Drawings to be restrained joint shall employ one of the restraining systems listed below. Restrained joints incorporating steel gripping wedges in rubber gaskets will not be allowed.
 - i. Snap-Lok Restrained Joint or Bolt-Lok Restrained Joint as manufactured by Griffin Pipe Products Co.
 - ii. Flex-Ring Restrained Joint or Lok-Ring Restrained Joint as manufactured by American Ductile Iron Pipe
 - iii. TR Flex Restrained Joint as manufactured by U.S. Pipe & Foundry Company

- e. Restraining Systems for Field Cuts: For field cuts on 24-inch diameter pipe and less, one of the restraining systems listed below shall be used. Larger diameter pipes shall be installed as recommended by the Engineer.
 - i. Field Flex-Ring as manufactured by American.
 - ii. Snap-Lok FC or Bolt-Lok FC as manufactured by Griffin Pipe Products Co.
 - iii. TR Flex Gripper Rings as manufactured by U.S. Pipe.
 - iv. MEGALUG mechanical joint restraint system shall be used only if approved by Engineer.
 4. Fittings: Fittings shall be in accordance with ANSI/AWWA C110/A21.10 or ANSI/AWWA C153/A21.53 and shall have a pressure rating of not less than that specified for the pipe. Fittings used with ductile iron pipe shall be ductile iron or cast iron. Fittings for pipe with mechanical joints shall have mechanical joints. Fittings for pipe with push-on joints shall have either mechanical joints or push-on joints. All fittings shown on the Drawings to have restrained joints shall employ one of the restraining systems specified in Paragraph 2.02.B.3.d of this Section. Restrained joints incorporating steel gripping wedges in rubber gaskets will not be allowed.
 5. Coatings: Pipe and fittings shall be furnished with exterior bituminous coating conforming to ANSI/AWWA C 151/A 21.51.
 6. Linings: Pipe and fittings shall have a hydrogen sulfide resistant interior lining of either Protecto 401 Ceramic Epoxy as manufactured by Induron Coatings, Inc. or PolyBond Plus as manufactured by American Ductile Iron Pipe. Lining shall be installed and field cuts shall be repaired as recommended by the manufacturer.
 7. Polyethylene Encasement: All ductile iron pipe and fittings shall be wrapped with a seamless polyethylene tube encasement, ANSI/AWWA C105/A21.5, LLD-8 mil or HDCL-4 mil, and installed in accordance with Method A. All lumps of clay, mud, cinders, etc. shall be removed from the pipe prior to installing the polyethylene tube encasement. Where ductile iron pipe is embedded or encased in concrete, the polyethylene tube shall be installed over the pipe for 5 feet either side of each end of the concrete encasement.
- C. Polyvinyl Chloride (PVC) Pressure Pipe and Fittings: Pipe and fittings shall conform to AWWA C900 for pipe diameters of 4-inch through 12-inch and AWWA C905 for pipe diameters 14-inch through 24-inch, except as otherwise specified herein.
1. General: Furnish maximum pipe lengths normally produced by the manufacturer, except for fittings, closures and specials. Pipe shall be used only for pressure flow systems.

2. Materials
 - a. The pipe shall be made of PVC plastic having a minimum cell classification of 12454 as defined in ASTM D1784. The pipe materials shall have a minimum hydrostatic design stress of 4,000 psi at 73.4°F per the requirements of PPI TR-3 as issued by the Plastic Pipe Institute. Additives and fillers including but not limited to stabilizers, antioxidants, lubricants, colorants, etc., shall not exceed 20 parts by weight per 100 of PVC resin in the compound. The compounding ingredients may consist of lubricants, stabilizers, non polyvinyl chloride resin modifiers, and pigment essential for processing, property control, and coloring. Certification of resin compounding shall be provided by the pipe manufacturer prior to shipment to the job site.
 - b. One test to verify resin compounding may be required by the Engineer and/or JCW. The test shall be performed by an independent testing laboratory approved by JCW and shall be performed upon a sample of pipe obtained from the job site. The cost of the test shall be paid for by the Contractor and shall be included with the bid price for pipe. The test shall be performed in accordance with ASTM D2584 Standard Test Method for Ignition Loss of Cured Reinforced Resins.
 3. Design: Pressure flow systems (force mains) shall have a minimum wall thickness conforming to DR 18 and a minimum pressure class of 150 psi. Wall thickness greater than DR 18, as required for design pressures or cyclic fatigue, shall be as shown on the Drawings.
 4. Joints: Pressure flow systems shall be joined in accordance with ASTM D3139 with particular attention given to Section 5.3. Elastomeric seal (gasket) shall have a basic polymer of synthetic rubber, except when the gasket is anticipated to come in contact with petroleum based products in which case oil-resistant Nitrile (Buna-N) gaskets shall be used. Natural rubber gaskets will not be accepted.
 5. Fittings: Fittings for pressure flow systems shall be ductile iron or cast iron mechanical joint fittings and shall conform to paragraph 2.02.B.4 of this Section with the required lining per paragraph 2.02.B.6 of this Section.
- D. Type PSM Polyvinyl Chloride (PVC) Gravity Sewer Pipe and Fittings (8-inch through 15-inch diameters only): Pipe and fittings shall conform to ASTM D3034, except as otherwise specified herein.
1. General: Furnish maximum pipe lengths normally produced by the manufacturer except for fittings, closures and specials.
 2. Materials
 - a. The pipe shall be made of PVC plastic having a minimum cell classification of 12454 or 13364 as defined in ASTM D1784.

- c. Absorption Test per ASTM C497, Section 7, Method A:
 - i. Obtain two core samples (one each from the middle area of two pipes for each mix design).
 - ii. Maximum allowable absorption value: 6.5%.
- d. Hydrostatic Test per ASTM C497: One piece of production pipe selected by the Engineer shall meet the following criteria:
 - i. 24-hour presoak (manufacturer's option).
 - ii. Hydrostatic pressure of 13 psi minimum shall be maintained for 20 minutes.
 - iii. End bulkheads or internal plugs may be used at the manufacturer's option. Leakage at the bulkhead of plugs is allowed if leakage does not interfere with the test.
 - iv. Allowable leakage: none. Moisture appearing on the exterior surface of the pipe in the form of beads adhering to the surface will not be considered leakage. The tests may be repeated after the 24-hour presoak at the manufacturer's option to determine if test pipe stops leaking. Pipe which stops leakage after the presoak will be considered to have passed.
- e. Visual Inspection: Pipe inspection shall include the following:
 - i. Joints.
 - ii. Interior surface finish and textures.
 - iii. Reinforcing steel placement and twist. Concrete from a portion of one piece of green pipe shall be stripped or raked to determine cage twist, location, clearance, and voids. Voids around reinforcing steel cage caused by cage twist will not be acceptable. Cage twist resulting from pipe production in excess of 1/4 inch in eight (8) feet will not be acceptable.
 - iv. Longitudinally cut pipe. One pipe shall be longitudinally sawcut in half using equipment which will not damage the uncut concrete or reinforcing steel. The exposed surface shall be inspected for voids adjacent to the circumferential steel. Voids shall be considered continuous if a 1/16-inch diameter pin can be inserted 1/4 inch deep. This test will be acceptable if no more than 10 percent of the circumferential bars exposed have continuous voids.
- f. Plant Inspection:

- i. Plant inspection shall include cage manufacturing, curing process, batching equipment and process, aggregate and cement storage, concrete mix designs, and product handling.
 - ii. If the Engineer determines that the forms, end rings, or form gaskets used in the manufacture of the pipe are inadequate, the Contractor shall replace or repair said equipment to the satisfaction of the Engineer.
3. Design: All pipe shall have a wall thickness "B" or "C". Contractor shall provide documentation supporting the selected strength class of the pipe based on earth loadings and the chosen pipe bedding. Reinforcement shall be circular. Modified or special designs are prohibited unless so specified in the Modifications to Detailed Specifications or approved by Engineer.
4. Materials
 - a. Fine aggregate shall be natural sand conforming to ASTM C33. Artificial or manufactured sand will not be acceptable. Coarse aggregate shall be crushed limestone conforming to ASTM C33, except that clay and shale particles shall not exceed one percent.
 - b. O-ring gaskets shall be synthetic rubber, circular in cross-section and shall conform to AWWA C 302.
 - c. Portland cement used in the reinforced concrete pipe shall provide high sulfate attack resistance. Portland cement shall be Type III or V per ASTM C150 and shall not contain tricalcium aluminate in excess of 5 percent, or shall be Type II per ASTM C150 with the addition of Class F pozzolan. The proportion of portland cement shall not be less than 560 pounds per cubic yard of concrete.
 - d. The aggregate shall be so graded, proportioned, and thoroughly mixed in a batch mixer to produce a homogeneous concrete mixture of such quality that pipe will conform to the test and design requirements of these specifications.
5. Joints: Joints shall conform to ASTM C443, except as otherwise specified herein.
 - a. Pipe and fittings, 36-inches in diameter and larger, shall be furnished with steel end ring joint, spigot groove and O-ring gasket. Pipe and fittings, less than 36-inches in diameter, shall be furnished with either integral concrete type joint with O-ring gasket or steel end joint with spigot groove and O-ring gasket.
 - b. Joint Coating and Sealing: All joints shall be inspected by the manufacturer, repaired, smoothed and cleaned in preparation for coating. The entire joint surface (pipe ends and mating surfaces) of both the bell and spigot will be coated with an epoxy ester equal to or exceeding specifications of single-package epoxy

manufactured by Perfection Paint and Color Company of Indianapolis, Indiana. Application shall be in accordance with the manufacturer's recommendations, to produce a smooth, continuously coated joint mating surface and cover pipe ends.

- c. For machine-made pipe with steel end ring joints, a five-inch wide steel skirt, minimum 16 gauge, shall be welded to the spigot joint ring of the pipe. The protective coating on the steel joint ring shall be repaired after welding.
 - d. All surfaces of steel joint rings in finished pipe shall have a shop-applied coat of Tnemec 37-77 Chem-Prime to a dry film thickness of 3.5 mils.
 - e. For steel end ring joints, interior joint space shall be filled with a preformed bead of butyl rubber joint sealer containing a minimum butyl content of 60% and conforming to ASTM C990 placed prior to joining. Prime the surfaces prior to joining. Join pipe with sufficient force to squeeze out sealing material around interior joint. Trim off excess to obtain flush surface around interior joint space. Do not apply joint sealer by pointing or grouting after joining.
 - f. For steel end ring joints, exterior joint space shall be filled by one of the following methods:
 - i. With preformed closed-loop joint filler composed of flexible, water degradable polyurethane foam into which is dispersed unhydrated Portland cement of not less than 63 percent by total weight. Joint filler shall be installed against the concrete spigot shoulder behind the steel spigot ring gasket groove. Join pipe with sufficient force to compress the joint filler.
 - ii. With preformed bead of butyl rubber joint sealer containing a minimum butyl content of 60% and conforming to ASTM C990 placed prior to joining. Prime the surface prior to joining.
6. Fittings and Specials: Provide strength equal to design D-loads of adjacent pipe and fabricate as one of the following types:
- a. Steel cylinder segments not less than U.S. No. 16 gauge lined with three-fourths (3/4) inch concrete or mortar and reinforced concrete exterior.
 - b. Concrete pipe sections cut while still green, reinforcing exposed and welded together at junctions and miters. Splice shall be built up to nominal wall thickness with mortar or concrete.
 - c. Miters shall not exceed 30 degrees at deflection angles between segments. Minimum center line curve radius shall not be less than twice the pipe diameter.

7. Corrosion Protection: Corrosion protection in the form of a plastic liner shall be used when specified on the Drawings or in the Modifications to Detailed Specifications. The plastic liner shall be integrally cast with the concrete pipe sections per SECTION 6650 - PLASTIC LINER FOR PROTECTION OF CONCRETE.
8. Marking: All pipe shall be clearly marked with the class, date of manufacturer, method of manufacture and the manufacturer's name or trademark.
9. General Manufacturing Requirements
 - a. Wet-Cast Pipe: Wet-cast RCP shall be manufactured by placing the concrete into stationary, vertical, cylindrical metal forms. During placing of each batch, the concrete shall be vibrated continuously with internal or external mechanical vibrators.
 - b. Spun Pipe: Spun RCP shall be manufactured by introducing the concrete into a rotating horizontal cylindrical metal form. After the concrete materials have been mixed, they shall be promptly placed in the forms and spun on a horizontal axis. If, for any reason, the work of filling the forms is interrupted long enough for the concrete to take its initial set, any partly filled form shall be emptied and the concrete rejected. While the concrete is being placed in the forms, they shall be revolved on a horizontal axis at speed that will ensure uniformity of aggregates. After all the concrete has been placed in the forms, they shall be revolved at proper speed and duration to secure a dense concrete with smooth interior surface. Water and laitance collecting on the surface of the concrete shall be removed, and the interior surface of the pipe shall be troweled and finished to the form of a true cylinder.
 - c. Machine-Made Pipe
 - i. Machine-made RCP shall be manufactured by placing the concrete between vertical cylindrical forms or by placing the concrete into a vertical form and the interior surface formed with one or more roller packing heads and a long bottom-trowel rotating in opposite directions. The concrete shall be mixed to a uniform consistency and the reinforcing cage shall be held by fastening (supports) and/or retractable mechanical devices to ensure correct cage position.
 - ii. Concrete placed between inner and outer forms shall be continuously vibrated throughout the manufacturing cycle. After all concrete has been placed in the forms, axial pressure shall be applied simultaneously with vibration to further densify the concrete, or the concrete shall be placed against the outer jacket and densified by continuous vibration during the manufacturing cycle. On

completion of densification, the pipe may be removed immediately from the forms.

10. Plant Testing: Machine-made pipe smaller than 36-inch diameter shall be vacuum tested to a minimum of 6.4 psi pressure differential and a leakage rate not to exceed 0.0017 CFM per square foot of internal pipe surface area. Test bulkheads must exactly simulate a bell and a spigot joint ("flat" bulkheads or plugs will be unacceptable). On pipe larger than 33-inch in diameter, a hydrostatic test shall be conducted on two pieces of each diameter and class for every two thousand feet of reinforced concrete pipe. However, not less than two pieces for each diameter and class shall be tested for diameters larger than 33-inches. Hydrostatic tests shall be conducted in accordance with ASTM C497 latest revision. The hydrostatic pressure requirement shall be 13 psi. Detailed testing procedures and schedule shall be submitted to the Engineer prior to in-plant testing. At the option of JCW, the tests shall be witnessed by a representative of JCW. Copies of test results shall be forwarded to JCW.
11. Causes for Rejection: Inspection of pipe, as may be deemed necessary by the Owner, will be made at the place of manufacture, the point of delivery, and/or at the time of installation, and unless it can be repaired by methods approved by the Engineer, pipe may be rejected for any of the following reasons:
 - a. A piece of any size broken out of the pipe.
 - b. Defects that indicate imperfect mixing or molding.
 - c. Any crack extending, entirely through the wall of pipe and having a longitudinal or transverse length greater than the wall thickness of the pipe.
 - d. Any shattering or flaking of concrete at a crack.
 - e. A deficiency greater than 1/4 inch from the specified wall thickness of pipe 30-inches or smaller in diameter, or a deficiency greater than 5 percent from the specified wall thickness of pipe larger than 30-inches in internal diameter, except that the deficiency may be 7% adjacent to the longitudinal joint, provided that additional deficiency does not lie closer than 20% of the internal diameter to the vertical axis of the pipe and does not extend along the circumference for a distance greater than 20 percent of the internal diameter.
 - f. The deficiencies in wall thickness permitted herein do not apply to gasket contact surfaces in gasketed joint pipe. Dimensions and tolerance of such contact surfaces shall be submitted for approval.
 - g. Internal diameter varies from a true circle of the specified diameter by more than 1%.

- h. The roundness of the pipe varies from a true circle of the actual internal diameter by more than one percent at any location along the barrel.
 - i. Rock pockets and water pockets in any pipe.
 - j. Exposure of any reinforcement arising from misplacement thereof.
 - k. Evidence of cage twist or misplacement of reinforcement.
 - l. Delaminating of the concrete.
 - m. Surface defects indicating honeycomb or open-texture.
 - n. Separations or "blisters".
 - o. Slumped or sagged concrete.
 - p. For sewer pipe, any crack showing two visible lines or separation for a continuous length of two (2) feet or more, or an interrupted length of three (3) feet or more anywhere in evidence, both inside and outside, except where such cracks occur during the external loading test specified herein.
 - q. Any continuous crack or concrete separation having a surface width of 0.010 inch or more and extending for a length of 12 inches or more, regardless of depth or position in the wall of the pipe.
 - r. The pipe fails the D-load bearing strength test.
- G. Fiberglass (Glass-Fiber-Reinforced Thermosetting-Resin) Wastewater Pipe (8-inch diameter and larger):
- 1. General: This specification designates requirements for fiberglass glass-fiber reinforced thermosetting-resin pipe (RTRP) for the conveyance of wastewater. Pipe for gravity application shall conform to ASTM D3262 for "Fiberglass" (Glass-Fiber-Reinforced Thermosetting-Resin) Sewer Pipe. Pipe for force main applications shall conform to ASTM D3754 for "Fiberglass" (Glass-Fiber-Reinforced Thermosetting-Resin) Sewer and Industrial Pressure Pipe. If ASTM D3754 pipe is selected, its actual outside diameter shall be in accordance with AWWA C950 Fiberglass Pressure Pipe.
 - 2. Materials: Material used in the manufacture of the pipe, fittings and specials shall conform to the following:
 - a. Resin Systems: The manufacturer shall use only polyester resin system with a proven history of performance in corrosive environments found in wastewater collection systems. The historical data shall have been acquired from a composite material of similar construction and composition as the proposed product. Certification of resin compounding shall be provided by the pipe

manufacturer prior to shipment to the job site. One test to verify resin compounding may required by the Engineer and/or JCW. The test shall be performed by an independent testing laboratory approved by JCW and shall be performed upon a sample of pipe obtained from the job site. The cost of the test shall be paid for by the Contractor and shall be included with the bid price for pipe. The test shall be performed in accordance with ASTM D2584 Standard Test Method for Ignition Loss of Cured Reinforced Resins.

- b. Glass Reinforcements: The reinforcing glass fibers used to manufacture the components shall be of the highest quality commercial grade E-glass filaments with binder and sizing compatible with impregnating resins.
 - c. Silica Sand: Sand shall be minimum 98% silica with a maximum moisture content of 0.2%.
 - d. Additives: Resin additives, such as curing agents, pigments, dyes, fillers, thixotropic agents, etc., when used, shall not detrimentally effect the performance of the product.
 - e. Elastomeric Gaskets: Gaskets shall meet ASTM F477 and be supplies by qualified gasket manufacturers and be suitable for the service intended.
3. Stiffness: Pipe shall conform to the requirements of AWWA M45 for the size and strength. Minimum pipe stiffness at 5-percent deflection shall be 46-psi (3.2-kg/cm²) for gravity and pressure wastewater conduit as specified for all sizes when calculated in accordance with ASTM D2412 Test Method for Determination of External Loading Characteristics of Plastic Pipe by Parallel-Plate Loading.
 4. Joints: Joint tightness shall be tested in accordance with ASTM D4161 for "Fiberglass" (Glass-Fiber-Reinforced Thermosetting-Resin) Pipe Joints Using Flexible Elastomeric Seals. Unless otherwise specified, the pipe shall be field connected with fiberglass sleeve couplings that utilize elastomeric sealing gaskets as the sole means to maintain joint water-tightness.
 5. Fittings: Fittings shall conform to ASTM D5685 Fiberglass (Glass-Fiber-Reinforced Thermosetting-Resin) Pressure Pipe Fittings or D3840 Standard Specification for "Fiberglass" (Glass-Fiber-Reinforced Thermosetting-Resin) Pipe Fittings for Non-pressure Applications.
 6. Testing: Pipe shall be tested for inside and outside diameter, wall thickness, squareness of pipe ends, chemical requirements, stiffness, and beam strength as specified in the following standards:
 - a. ASTM D3681 Test Method for Chemical Resistance of "Fiberglass" (Glass-Fiber-Reinforced Thermosetting-Resin) Pipe in a Deflected Condition

- b. ASTM D2412 Standard Test Method for Determination of External Loading Characteristics of Plastic Pipe by Parallel-Plate Loading
- c. ASTM D3262 Standard Specification for "Fiberglass" (Glass-Fiber-Reinforced Thermosetting-Resin) Sewer Pipe.

H. High Density Polyethylene (HDPE):

- 1. Pipe and Fittings: All new pipe and fittings shall be solid wall high density polyethylene (HDPE) pipe, meeting the requirements of ASTM F714 Polyethylene (PE) Plastic Pipe (SDR-PR) based on outside diameter, ASTM D1248, ASTM D3350. All HDPE pipe shall be marked with a green stripe to signify its use for sanitary sewer utilities.
 - a. The pipe shall be manufactured from high density high molecular weight polyethylene resin which conforms to ASTM D1248. The pipe produced from this resin shall have a minimum cell classification of 345434C under ASTM D3350.
 - b. The HDPE pipe shall have a wall thickness as shown on the Drawings with a minimum wall thickness conforming to DR11 with a working pressure rating of 160 psi. HDPE pipe diameters shown on plans are iron pipe sizes which provide the nominal inside diameter necessary to exceed the flow capacity of cement lined ductile iron pipe.
 - c. The pipe and fitting manufacturer shall certify that samples of his production pipe have undergone stress regression testing, evaluation, and validation in accordance with ASTM D2837 and PPI TR-3. Under these procedures, the minimum hydrostatic design basis shall be certified by the pipe manufacturer to be 1600 psi at 73.4°F and 800 psi at 140°F.
 - d. As approved by JCW, electrofusion fittings may be allowed in lieu of fittings designed for butt fusion.
 - e. The HDPE pipe shall be provided to the project site in straight sections and shall not have been coiled at any time.

2.03. TEES, WYES, AND BUILDING SERVICE LINES

All service lines are gravity. Tees, wyes, and building service lines shall be installed as shown on the Drawings or specified herein. Saddles will only be allowed on VCP and with the approval of JCW.

A. Acrylonitrile-Butadiene-Styrene (ABS) Service Line Pipe and Fittings

- 1. Pipe and fittings shall conform to ASTM D2751 SDR 23.5, ASTM D1527 Schedule 40, ASTM F628 Foamed Core DWV, ASTM D2661 DWV.
- 2. Joints: Joints shall be solvent-cemented. The cement shall conform to the requirements of ASTM D2235.

- B. Polyvinyl Chloride (PVC) Service Line Pipe and Fittings
 - 1. Pipe and fittings shall be made of PVC plastic pipe having a minimum cell classification of 12454 as defined in ASTM D2241 or ASTM D3034 for SDR26.
 - 2. Joints: Joints shall be of a push-on type with a bell-end grooved to receive a synthetic rubber gasket. Solvent welded joints are not allowed. The joint shall be made in accordance with ASTM D3212.
- C. High Density Polyethylene (HDPE) Service Line Pipe and Fittings:
 - 1. The pipe shall be manufactured from high density high molecular weight polyethylene resin which conforms to ASTM D1248. The pipe produced from this resin shall have a minimum cell classification of 345434C under ASTM D3350.
 - 2. As approved by JCW, electrofusion fittings may be allowed in lieu of fittings designed for butt fusion.
- D. Ductile Iron Pipe (DIP) Service Line Pipe and Fittings: Refer to paragraph 2.02.B of this Section for requirements for DIP service line pipe and fittings.

PART 3 EXECUTION

3.01. PRODUCT HANDLING

The Manufacturer and Contractor shall use equipment and methods adequate to protect the pipe, joint elements and prevent shock contact of adjacent units during moving or storage. Damaged sections that cause reasonable doubt as to their structural strength or water-tightness will be rejected.

3.02. SITE PREPARATION

Site preparation and earthwork shall be completed as specified in SECTION 2230 - SITE PREPARATION AND EXCAVATION.

3.03. TRENCHING AND BACKFILLING

Trenching and backfilling shall be completed as specified in SECTION 2315 - TRENCHING AND BACKFILLING.

3.04. PIPE INSTALLATION

Pipe shall be installed as specified in SECTION 2536 - SEWER PIPE INSTALLATION.

3.05. MATERIAL TESTING

Testing shall be completed as specified in SECTION 2536 - SEWER PIPE INSTALLATION and SECTION 2539 - TESTING LABORATORY SERVICES.

END OF SECTION 2534

SECTION 2536 - SEWER PIPE INSTALLATION

PART 1 GENERAL

1.01. WORK INCLUDED IN THIS SECTION

This section governs construction methods and procedures for the installation of gravity and pressure pipelines in accordance with Contract Documents, Drawings, General Conditions and these specifications.

1.02. SPECIFICATION MODIFICATIONS

It is understood that throughout this section these Specifications may be modified by appropriate items in the Modifications to Detailed Specifications or notes on the Contract Drawings.

1.03. REVISIONS OF STANDARDS

When reference is made to a Standard Specification i.e. ASTM, ANSI, AWWA, MCIB, the Specification referred to shall be understood to mean the latest revision of said specification as amended at the time of the Notice to Bidders, except as noted on the Drawings or in the Modifications to Detailed Specifications.

1.04. SUBMITTALS

The Contractor shall provide certifications or shop drawings on all materials provided under these specifications in accordance with the General Requirements.

1.05. DETAILED INSTALLATION REQUIREMENTS

Sanitary sewer line installation shall comply with applicable State and Federal requirements. Except as modified herein, all pipes shall be installed in accordance with the following standards:

- A. ASTM D2321 - PVC and HDPE Pipe.
- B. ANSI/AWWA C600 - Ductile Iron Pipe.
- C. Reinforced Concrete Pipe - Installed in accordance with American Concrete Pipe Association's "Installation Manual".
- D. Fiberglass (Glass-Fiber-Reinforced Thermosetting-Resin) Wastewater Pipe
 - 1. Gravity Sewer: Installed in accordance with ASTM D3839 Standard Guide for Underground Installation of "Fiberglass" (Glass-Fiber-Reinforced Thermosetting-Resin) Pipe
 - 2. Force Main: Installed in accordance with AWWA Manual M45, Fiberglass Pipe Design
- E. High Density Polyethylene (HDPE) Joints - Assembled in accordance with ASTM D2657 - Standard Practice for Heat Fusion Joining Polyolefin Pipe and Fittings

PART 2 PRODUCTS

2.01. PIPE EMBEDMENT MATERIALS

- A. All materials used for granular embedment for pipe bedding shall conform to the requirements of ASTM C33 and shall meet the following gradation:

Sieve Size Gradations	Percentage Passing
3/4	100
1/2	90 - 100
3/8	20 - 55
No. 4	0 - 5
No. 8	0 - 2.5
No. 200	0 - 2.5

- B. Testing by a qualified independent testing laboratory to verify the gradation, deleterious materials content, soundness, Los Angeles Abrasion loss, and freeze-thaw loss of the aggregate used for pipe bedding may be required by the Engineer or JCW. The Engineer or JCW may request that the bedding aggregate testing be performed on a maximum of one successful test per 500 tons of aggregate used on the project. The Contractor shall include the cost of said testing in his bid.

2.02. CONCRETE

Concrete shall conform to SECTION 3000 - CAST-IN-PLACE CONCRETE.

2.03. REINFORCING STEEL

Reinforcing steel, when required, shall be placed as shown on the Drawings and shall conform to SECTION 3000 - CAST-IN-PLACE CONCRETE.

2.04. ENCASUREMENT MATERIALS

- A. Pipe encasement materials shall be furnished and installed to complete the work shown on the Drawings or as is called for in the Contract Documents. Pipe encasement, when required and/or permitted, is intended to provide maximum support for pipe in locations where standard embedment may be insufficient.
- B. Concrete used for pipe encasement shall be "Class B" concrete as specified in SECTION 3000 - CAST-IN-PLACE CONCRETE.
- C. Reinforcing steel, when required, shall conform to SECTION 3000 - CAST-IN-PLACE CONCRETE.

2.05. MANHOLE MARKERS

Manhole markers shall be constructed of the following items. See Paragraph 3.08 of this Section for installation of the manhole markers.

- A. Steel tee post.
- B. 6' long x 2" diameter safety yellow PVC pipe.

- C. 2" safety yellow PVC cap.

PART 3 EXECUTION

3.01. GENERAL

- A. Trench Dewatering: Contractor shall maintain a dry and stable trench, obtain necessary permits, and provide for the proper method of discharging such water from the work site at all times until pipeline installation is completed to the extent that hydrostatic pressure flotation or other adverse effects will not result in damage to the pipeline. Proper dewatering techniques are the Contractor's sole responsibility. All work performed by the Contractor which is adversely affected by his failure to adequately dewater trenches will be subject to rejection by the Engineer. The Contractor shall repair and/or replace the affected pipeline without additional compensation. Additional dewatering requirements are defined in SECTION 2230 - SITE PREPARATION AND EXCAVATION.
- B. Trench Shoring and Bracing:
 - 1. All shoring, bracing or blocking, shall be furnished and installed as necessary to preserve and maintain exposed excavation faces, to protect existing improvements, to protect the proposed pipeline and to provide for safety.
 - 2. Shoring or other methods for support of trench walls is the responsibility of the Contractor and shall be accomplished by methods which will not adversely affect pipeline alignment, grade and/or structural integrity.
 - 3. All bracing, sheeting and/or shoring installed below a horizontal plane twelve (12) inches above top of proposed pipe, shall not be disturbed or removed after pipe and/or pipe embedment has been installed, unless otherwise specified. The bottom skids of a trench-shield shall not extend lower than twelve (12) inches above top of proposed pipe.

3.02. PIPE EMBEDMENT

- A. Pipe Embedment Designations and Descriptions:
 - 1. Class A Embedment - Concrete Cradle, Arch or Encasement
 - a. All Class A embedment require "Class B" concrete as specified in SECTION 3000 - CAST-IN-PLACE CONCRETE. After initial set of concrete, one (1) foot of backfill material should be placed over the conduit or concrete. The backfill above this point shall not be placed nor sheeting removed until at least forty-eight (48) hours after placement of the concrete. Time requirements may be adjusted by the Engineer to obtain structural integrity.
 - b. Class A embedment for all pipe shall be installed with reinforcing steel as shown on the Drawings, but in no case less than $p = 0.4\%$, where p is the ratio of the area of steel to the area of concrete, or as otherwise specified. Reinforcing steel shall be

uniformly spaced and have a minimum lap of sixteen (16) bar diameters.

- c. Place pipe that is to be bedded in Class A concrete embedment in proper position on temporary supports consisting of concrete blocks or bricks. When necessary, anchor or weight the pipe to prevent flotation when the concrete is placed.
- d. Place concrete for Class A embedment uniformly on each side of the pipe and deposit at approximately its final position. Do not move concrete more than five (5) feet from its point of placement. All Class A embedment shall begin and end at a pipe joint.

2. Class B Embedment (RCP Optional)

- a. The pipe shall be bedded in granular material, with a minimum thickness below the pipe as specified in the Table of Bedding Depths and Side Clearances in the JCW Standard Detail Drawing. The granular material shall be placed to the horizontal centerline of the pipe. The backfill from the horizontal centerline to a level not less than twelve (12) inches above the top of pipe shall be carefully placed select earth backfill compacted to at least 90% of maximum dry density at a moisture content within 2% of the optimum moisture as defined in ASTM D698. The select material shall be free from debris, organic matter, frozen material and rocks larger than one (1) inch.

3. Class C Embedment (RCP)

- a. The pipe shall be bedded in granular material with a minimum thickness beneath the pipe as specified in the Table of Bedding Depths and Side Clearances in the JCW Standard Detail Drawing.
- b. Granular material shall be placed under the haunches of the pipe to a height one-sixth (1/6) of the outside diameter of the pipe. Backfill above the bedding to a point twelve (12) inches above the pipe shall be carefully placed select earth backfill compacted to at least 90% of maximum dry density at a moisture content within 2% of the optimum moisture as defined in ASTM D698. The select material shall be free from debris, organic matter, frozen materials and rocks larger than one (1) inch.

4. Flexible Pipe Embedment (PVC Pipe, DIP, Fiberglass Wastewater Pipe & HDPE)

- a. The pipe shall be bedded in granular material with a minimum thickness beneath the pipe as specified in the Table of Bedding Depths & Side Clearances in the JCW Standard Detail Drawing. The pipe shall also be backfilled with bedding aggregate to a level not less than twelve (12) inches above the top of the pipe bell.

B. Embedment Requirements:

1. Class A Embedment shall be used as shown on the Drawings, for trench widths that exceed the design requirements, as required by the Engineer for unstable soils, or at stream crossings.
2. Class B Embedment may be used for reinforced concrete pipe (RCP) at the Contractor's discretion or where required by the Engineer.
3. Class C Embedment shall be used for reinforced concrete (RCP), except when installation depths will result in loads exceeding the pipe's safe supporting strength.
4. Flexible Pipe Embedment shall be used for polyvinyl chloride pipe (PVC) pipe, Fiberglass Wastewater Pipe, DIP, and HDPE pipe. Installation shall be in strict conformance with instructions for the appropriate Class being utilized.

C. Bedding Installation:

1. The trench subgrade shall be prepared to provide a uniform and continuous pipe support between pipe bells and joints.
2. Place and densify embedment material by shovel slicing, or vibrating, and prepare embedment material so that the pipe will be true to line and grade after installation.
3. After each pipe has been brought to grade, aligned, and placed in final position, deposit and densify by shovel slicing sufficient bedding material under the pipe haunches and on each side of the pipe to hold the pipe in proper position during subsequent pipe jointing, bedding, and backfilling operations. Place bedding material uniformly and simultaneously on each side of the pipe to prevent lateral displacement.
4. If unstable subgrade conditions are encountered and it is determined by the Engineer that the bedding specified will not provide suitable support for the pipe, additional excavation to the limits determined by the Engineer will be required. This additional excavation shall be backfilled with granular embedment material approved by the Engineer.

3.03. PIPE LAYING

A. General

1. All pipe shall be installed in accordance with the pipe manufacturer's recommendations, except as modified herein.
2. Pipe laying operations shall not proceed if the trench width as measured at the top of pipe exceeds the maximum allowable trench width as defined in SECTION 2315 - TRENCHING AND BACKFILLING. If this occurs the Contractor shall provide, upon submittal to the Engineer for approval, a better class of bedding for the pipe or pipe of sufficient strength to provide safe supporting strength.

3. All pipe and fittings shall be stored and handled with care to prevent damage thereto. Do not use hooks to transport or handle pipe or fittings. Do not drop pipe or fittings.
 4. Rejected pipe and fittings shall be marked and removed from the Project Site at no cost to the Owner. All pipe and fittings shall be examined for soundness and specification compliance prior to placement in the trench and rejected pipe or fittings shall not be incorporated into the pipeline. The Contractor shall check the class or pipe strength to be sure proper pipe is installed.
 5. Clean joint contact surfaces prior to jointing. Use lubricants, primers, adhesives, and touch-up coatings as recommended by the pipe or joint manufacturer.
 6. Pipe laying normally shall begin at the lowest point and proceed in the upstream direction unless approved by JCW. The Contractor will not be allowed to lay any pipe if manholes are not on the project site. The pipe laying upstream of a manhole shall not proceed until the base of the manhole has been placed and leveled.
 7. Unless otherwise required, lay all pipe straight between manholes. Excavate bell holes for each pipe joint. When jointed, the pipe shall form a true and smooth pipeline.
 8. Pipe connecting to a structure shall be supported with Class A embedment, cradle or encasement, to a point twelve (12) inches outside the structure excavation. If flexible wall connections are used, Class B embedment may be used, in lieu of concrete embedment, provided the height of backfill does not result in loads exceeding the pipe's safe supporting strength. When the potential exists for the pipe to become un-centered within the manhole gasket, the Contractor shall institute such means necessary to prevent un-centering of the pipe in the gasket.
 9. All pipelines shall be plugged at the end of each day's progress. Plugs or other positive methods of sealing shall be utilized at all times to protect any existing system from entrance of stormwater or other foreign matter.
 10. When a sanitary sewer line crosses an existing pipeline and the clearance is less than two and one half (2.5) feet, Class A Embedment or Ductile Iron Pipe (DIP) shall be required.
- B. Gravity Sewers: All gravity sewers shall be installed to the alignment, elevation, slope, and with pipe embedment as specified and/or shown on the Drawings.
1. The grade lines shown on the profile drawings extend from the centerline of the top manhole to the centerline of the bottom manhole. Slope from the center of new manholes to the manhole walls of the incoming or outgoing pipes shall be added to the drops shown on the plans when establishing pipe invert elevations at manholes.

2. The pipes and appurtenances shall be truly laid to line and grade throughout, all junctions and other pieces required shall be properly excavated for and laid as shown on the Drawings, and the following tolerances from true horizontal alignment and vertical grade shall be maintained:
 - a. Horizontal Alignment: 12 inches
 - b. Vertical Grade: As shown on page 2536-**Error! Bookmark not defined.**

Pipe installed but not meeting these tolerances shall be ordered removed and replaced at the Contractor's cost and expense.

C. Pressure Sewers (Force Main)

1. All pressure sewers shall be installed with granular embedment per Paragraph 3.02 of this Section. All pressure sewers shall be laid to a continuous slope when not shown on the Drawings.
2. Approved air relief valves shall be installed at all locations shown on the Drawings or where required by the Engineer.
3. The Contractor shall restrain the pipeline to accommodate thrust and testing forces at pipe deflections, bends, tees, and plugs in accordance with the project Contract Documents. All damage caused by the Contractor's failure to provide adequate restraint shall be corrected by the Contractor at no additional cost to the Owner.
4. The Contractor shall obtain Kansas State Plane coordinates on the force main using survey-grade GPS equipment. The coordinates shall be obtained at 100-foot intervals on straight runs of pipe, at 25-foot intervals on curved runs of pipe, and at all fittings. The Contractor shall provide the coordinates to JCW in a digital format such as a comma delimited text file, a shape file, or a Microsoft Excel spreadsheet. The digital file shall identify the fittings with their corresponding coordinate pair.
5. All force mains shall be installed with the following in-ground identification.
 - a. Warning Tape: Warning tape shall be made of polyethylene, a minimum 4 mils thick, and a minimum of 6" wide with black lettering imprinted on a green background. Tape lettering shall include the words "CAUTION FORCE MAIN LINE BURIED BELOW", "JCW", and "913-715-8500" printed at regular intervals. The tape shall be installed 12 to 18 inches directly above the pipe and at least 6" below grade.
 - b. Tracer Wire: The tracer wire shall be a minimum AWG #12 XHHW copper wire. The tracer wire shall be installed no more than 6" above the top of the force main. Tracer wire shall be installed continuously along the new facility route with access

points placed every 300 hundred feet maximum. Tracer wire should be brought to the ground surface at the access points. Access points may include valve boxes, handholes, manholes, vaults or other covered access devices. Access point covers shall be clearly marked with the type of facility. Splices in the tracer wire should be connected by means of a split bolt or compression type connector to ensure continuity. The contractor shall perform continuity tests on the tracer wire after installation. If the tracer wire fails the continuity test, the Contractor shall repair the wire at no additional cost to the Owner.

- D. Ductile Iron Pipe: All field cut joints shall be repaired with an epoxy polyamide paint system. The cut surface of the pipe to be coated shall be dry and free of dirt, dust, sand, grit, mud, oil, grease, rust, loose mill scale, or other objectionable substances. Cleaning and painting operations shall be performed in a manner which will prevent dust or other contaminants from getting on freshly painted surfaces. Any damages to the lining system that result from the field cut shall be repaired according to the manufacturers recommendations.
- E. Fiberglass (Glass-Fiber-Reinforced Thermosetting-Resin) Wastewater Pipe: The maximum initial deflection of the Fiberglass Wastewater Pipe following open-cut installation shall be 2%. In accordance with paragraph 3.11 of this Section, the Contractor shall perform deflection testing following pipe installation to determine the initial deflection of the Fiberglass Wastewater pipe.
- F. High Density Polyethylene
 - 1. Pipe Joining:
 - a. The polyethylene pipe shall be assembled and joined at the site using the butt-fusion method to provide a leak proof joint. Socket fusion, extrusion welding or hot gas welding, threaded, or solvent-cement joints and connections are not permitted. Electrofusion fittings may be allowed as approved by JCW. All equipment and procedures used shall be used in strict compliance with the manufacturer's recommendations. Fusing shall be accomplished by personnel certified as fusion technicians by a manufacturer of polyethylene pipe and/or fusing equipment. Certifications for all personnel shall be submitted to the Engineer for review prior to the onset of work on this project.
 - b. The butt-fused joint shall be true alignment and shall have uniform roll back beads resulting from the use of proper temperature and pressure. The joint shall be allowed adequate cooling time before removal of pressure. The fused joint shall be watertight and shall have tensile strength equal to that of the pipe and shall indicate a ductile rather than brittle fracture when tested. All butt fused joints shall be subject to acceptance by the Engineer and/or his representative prior to insertion. All defective joints shall be cut out and replaced at no cost to JCW. Any section of the pipe with a gash, blister, abrasion, nick, scar, or other deleterious fault greater in depth than five percent (5%) of the wall thickness, shall

not be used and must be removed from the site. However, a defective area of the pipe may be cut out and the joint fused in accordance with the procedures stated above. In addition, any section of the pipe having other defects such as concentrated ridges, discoloration, excessive spot roughness, pitting, variable wall thickness or any other defect of manufacturing or handling in the opinion of the Engineer and/or his representative shall be discarded and not used.

- c. Butt fusion beads shall be uniform on both sides of the joint i.e. no wrinkles or discontinuities.
- d. The Contractor shall allow the HDPE pipe sufficient time to rest and contract in the trench prior to backfill, tie-ins, and connections.

2. Internal Bead Removal

- a. All internal beads shall be removed after the cooling time using a suitable bead removal tool. The bead removal tool shall not induce any slits, gouges or defects in the pipe wall.
- b. The beads shall be bent back at several positions. No evidence of the bead splitting shall be seen. If the bead is seen to split at any point then the joint shall be cut from the pipeline and remade. If a similar defect recurs, all further production jointing shall cease until the equipment has been thoroughly cleaned and examined. New trial joints shall be made and shown to be satisfactory.

G. Tees, Wyes and Building Service Lines: Tees, wyes, and building service lines shall be installed as shown on the Drawings or specified herein.

- 1. Tees, wyes and saddles shall be installed at forty-five (45) degrees and not less than thirty (30) degrees with pipe spring-line for pipe sizes 8 through 16 inch diameter. Tees, wyes and saddles shall not be installed in pipe sizes greater than or equal to eighteen (18) inch diameter.
- 2. Building service lines shall be installed with a straight alignment and at a uniform grade not less than two (2) percent for 4 inch diameter service lines and not less than one (1) percent for 6 inch diameter service lines unless otherwise specified and shall be embedded with Flexible Pipe Embedment. When a building service line grade exceeds thirty (30) percent, pipeline anchors shall be installed as required under paragraph 3.05, with the first anchor not more than twelve (12) nor less than seven (7) feet upstream of the tee or wye.
- 3. The Contractor shall maintain an accurate record for submittal to the Engineer of location, size and direction of each tee, wye, saddle and the elevation, location, size and length of each building service line. Locations shall use the pipeline stationing as shown on the Drawings, or the distance from the first downstream manhole. In the event such records are not kept, or are lost before final acceptance of the work, the required information shall be determined by the Contractor at no

additional cost to the Owner. A four (4) foot long wooden board or metallic locating tape shall be placed vertically at the end of each stub.

- 4. Saddles will not be allowed unless approved by JCW.

3.04. CONNECTION OF PIPES OF DISSIMILAR MATERIALS

The connection of pipes of different materials shall be made using one of the following transition couplings that provide a permanent and watertight connection which will withstand the hydrostatic test pressure and prevent the offset of the joint within the coupling:

- A. Pipe Diameter 27-inch and Smaller: Mission EZ Flex Coupling, Fernco Strongback RC Coupling, or approved equal.
- B. Pipe Diameter 30-inch and Larger: Fernco Coupling encased with Class A reinforced concrete encasement, or approved equal.

3.05. ANCHORS

Pipelines shall be anchored in accordance with the table below:

PIPELINE ANCHORS	
<u>Percent of Grade</u>	<u>Center to Center Max. Spacing (Feet)</u>
15-35	36
35-46	24

The anchor shall be constructed of cast-in-place concrete as shown on the JCW Standard Detail Sheet. Concrete anchors shall have a minimum thickness of twelve (12) inches. The anchor shall extend not less than one (1) foot into undisturbed earth on the sides and bottom and one (1) foot above top of pipe. In incompressible material, the above dimensions may be six (6) inches each side and bottom. The anchor shall support a joint fitting.

3.06. PROTECTION OF WATER SUPPLIES

- A. There shall be no physical connection between a public or private potable water supply system and a sewer, or appurtenance thereto, which would permit the passage of any wastewater or polluted water into the potable water supply.
- B. Sewer lines, i.e., house connections, laterals, trunk lines, interceptors, force mains, etc., shall not be constructed within a 100 foot radius of a public water supply well. Greater separation may be required where soil and drainage conditions indicate the need for greater protection. Sewer lines constructed of ductile materials may be constructed within 10 feet of a private water supply well.
- C. Parallel Placements: When gravity sanitary sewers and potable water pipes are laid parallel to each other, the horizontal distance between them shall not be less than 10 feet. The distance of separation shall be measured from edge to edge. The laying of gravity sanitary sewers and potable water pipes shall be in separate trenches with undisturbed earth between them.

- D. Crossing Placements: When a gravity sanitary sewer and a potable water pipe cross and the gravity sewer is 2 feet or more below the water pipe, no special requirements or limitations are provided herein. At all other crossings, the sanitary sewer shall be constructed of DIP, PVC pipe, or RCP and pressure tested to assure water tightness pursuant to paragraph 3.10 below. Joints in the gravity sewer pipe shall be located as far as practical from the intersected potable water pipe. At points where sewers cross above water mains, the sewer shall be encased in concrete for a distance of 10 feet in each direction of the crossing.
- E. Force Main Placements: When a force main runs parallel to a potable water pipe, the horizontal separation distance shall be a minimum of 10 feet. There shall be at least a 2 foot vertical separation at crossings with the force main always crossing under the potable water pipe.

3.07. IMPERVIOUS DITCH CHECKS

- A. Impervious ditch checks shall be placed where shown on the Drawings. Length shall be a minimum of five (5) linear feet. The height of the check shall extend to two (2) feet below finish grade. The impervious material shall be placed such that it is in contact with a stable foundation material. All fractured or unstable material surrounding the impervious material shall be removed prior to constructing ditch check. The ditch check shall be constructed of flowable fill as specified in SECTION 3000 - CAST-IN-PLACE CONCRETE. The backfill above the ditch check shall be free of debris, organic materials, and stones greater than 12-inches.

3.08. MANHOLE MARKERS

Where noted on Drawings, manhole markers shall be constructed by installing a 6-foot steel tee post into the ground with four (4) feet above grade. The tee post shall be placed within five (5) feet of the manhole cover on the side away from the slope of the eccentric cone (if used) so as to not damage the eccentric cone. The 6' long x 2" diameter PVC pipe shall be placed over the tee post and the PVC cap place on top of the PVC pipe.

3.09. VISUAL INTERNAL INSPECTION

Contractor shall clean and flush with clear water the pipe of excess mortar, joint sealant and other dirt and debris prior to inspection. Sewer will be inspected by flashing a light between manholes and/or by physical passage to determine the presence of any misaligned, displaced, or broken pipe and other defects.

3.10. SEWER PIPE EXFILTRATION TESTING

Exfiltration tests shall be conducted on sewers before acceptance by JCW. In lieu of exfiltration testing, hydrostatic testing per paragraph 3.11 below may be used with prior approval by JCW. Exfiltration tests shall be performed by the Contractor using one or a combination of methods as set forth below. The required air pressure and/or exfiltration testing shall be successfully performed on carrier conduits prior to filling the void between the casing and the carrier conduits with sand or the sealing of the ends of the casing conduits.

- A. Hydrostatic Tests for Pressure Systems:

1. Conformance Procedure: Perform hydrostatic pressure and leakage tests. Conform to AWWA C600 procedures as modified herein. Tests shall apply to all pressure sewers.
 2. Sectionalizing: Test in segments between sectionalizing valves, between a sectionalizing valve and a test plug, or between test plugs. Contractor shall furnish and install test plugs at no additional cost to the Owner, including all anchors, braces, and other devices to withstand hydrostatic pressure on plugs. Contractor shall be responsible for any damage to public or private property caused by failure of plugs. Limit fill rate of line to available venting capacity.
 3. Pressure Test: Conduct at 1.5 times maximum operating pressure determined by the following formula:
 - a. $P_{pt} = (1.5) * (.433) * (OP - GE)$, in which
 - i. P_{pt} = test pressure in psi at gauge elevation
 - ii. OP = operating pressure in feet as indicated for highest elevation of the hydraulic gradient on each section of the line.
 - iii. GE = elevation in feet at center line of gauge.
 - b. Perform pressure tests satisfactorily prior to determining leakage.
 4. Leakage Test
 - a. Conduct at maximum operating pressure as determined by the following formula:
 - b. $P_{lt} = 0.433 * (OP - GE)$, in which
 - c. P_{lt} = test pressure in psi at gauge elevation
 - d. OP and GE - as defined above
 - e. All joints shall be watertight and free from leaks.
- B. Air Testing of Gravity Systems (Except RCP and except Fiberglass Wastewater Pipe \geq 54" Diameter):
1. Each section of gravity pipeline between manholes and/or structures after backfill shall be tested as outlined below.
 - a. Contractor may perform air tests for all pipe sizes described above.
 - b. Furnish all facilities required including necessary piping connection, test pumping equipment, pressure gauges, bulkheads, regulator to avoid over-pressurization, and all miscellaneous items required.

- c. The pipe plug for introducing air to the sewer line shall be equipped with two taps. One tap will be used to introduce air into the line being tested through suitable valves and fittings, so that the input air may be regulated. The second tap will be fitted with valves and fittings to accept a pressure test gauge indicating internal pressure in the sewer pipe. Additional valve and fitting will be incorporated on the tap used to check internal pressure so that a second test gauge may be attached to the internal pressure tap. The pressure test gauge will also be used to indicate loss of air pressure due to leaks in the sewer line.
- d. The pressure test gauge shall meet the following minimum specifications:
 - i. Size (diameter): 4-1/2 inches
 - ii. Pressure Range: 0-15 psi
 - iii. Figure Intervals: 1 psi increments
 - iv. Minor Subdivisions: 0.05 psi
 - v. Pressure Tube: Bourdon Tube or diaphragm.
 - vi. Accuracy: +/-0.25% of maximum scale reading.
 - vii. Dial: White coated aluminum with black lettering, 270° arc and mirror edge.
 - viii. Pipe Connection: Low male 1/2 inch NPT.
 - ix. Calibration data not more than one year old will be supplied with all pressure test gauges. Certification of pressure test gauge will be required from the gauge manufacturer. This certification and calibration data will be available to the Engineer whenever air tests are performed.

2. Process

- a. Gravity sewer pipe is used it shall be air-tested in accordance with the requirements of ASTM F1417.
- b. Plug ends of line and cap or plug all connections to withstand internal pressure. One of the plugs provided must have two taps for connecting equipment. After connecting air control equipment to the air hose, monitor air pressure so that internal pressure does not exceed 5.0 psig. After reaching 4.0 psig, throttle the air supply to maintain between 4.0 and 3.5 psig for at least two (2) minutes in order to allow equilibrium between air temperature and pipe walls. During this time, check all plugs to detect any leakage. If plugs are found to leak, bleed off air, tighten plugs, and again begin supplying air. After temperature has stabilized, the pressure

is allowed to decrease to 3.5 psig. At 3.5 psig, begin timing to determine the time required for pressure to drop to 2.5 psig. If the pressure remains at 3.5 psig for 30 minutes with no drop, the pipe shall be presumed free of defects. If the pressure begins to slowly drop within the first 30 minutes and If the total time, in seconds, for the air pressure to decrease from 3.5 psig to 2.5 psig is greater than that shown in the table below, the pipe shall be presumed free of defects.

Pipe Diameter (in)	Minimum Time (min:sec)	Length for Minimum Time (ft)	Time for Longer Length (sec) L = Total Length
4	3:46	597	0.380 * L
6	5:40	398	0.854 * L
8	7:34	298	1.520 * L
10	9:26	239	2.374 * L
12	11:20	199	3.418 * L
15	14:10	159	5.342 * L
18	17:00	133	7.692 * L
21	19:50	114	10.470 * L
24	22:40	99	13.674 * L
27	25:30	88	17.306 * L
30	28:20	80	21.366 * L
33	31:10	72	25.852 * L
36	34:00	66	30.768 * L
42	39:48	57	41.883 * L
48	45:34	50	54.705 * L

- c. If air test fails to meet above requirements, repeat test as necessary after all leaks and defects have been repaired and backfilled.
- d. In areas where ground water is known to exist, install a one-half inch diameter capped pipe nipple, approximately 10" long, through manhole wall on top of one of the sewer lines entering the manhole. This shall be done at the time the sewer is installed. Immediately prior to the performance of the line acceptance test, ground water level shall be determined by removing pipe cap, blowing air through pipe nipple into the ground so as to clear it, and then connecting a clear plastic tube to pipe nipple. The hose shall be held vertically and a measurement of height in feet of water shall be taken after the water stops rising in this plastic tube. The height in feet shall be divided by 2.3 to establish the pounds of pressure that will be added to all readings.
- e. In lieu of the above paragraph, the Contractor may install a monitoring well to measure the height of the ground water prior to air testing. The monitoring well shall be sized to allow measurement of the ground water from the surface and extend

into the granular pipe bedding. The monitoring well shall be removed in a manner acceptable to the Engineer and JCW.

3. If the maintenance of existing flow in a pipe is necessary and air pressure testing is not possible, the Contractor shall perform closed circuit television inspection of the pipe per SECTION 1400 - PROJECT INTERNAL TELEVISION INSPECTION.

C. Air Testing of Gravity Systems (RCP and Fiberglass Wastewater Pipe \geq 54" Diameter):

1. Air pressure testing of individual joints shall be performed on the coupled joint to determine the soundness of the bell and spigot and the seal of the gasket. Joints that do not pass the joint air pressure test shall be uncoupled to determine the source of the leak, repaired and/or replaced, retested until the joint meets the test requirements.
2. Each joint of pipe shall be tested as outlined below and in accordance with ASTM C1103. The joint testing shall occur immediately after the joint is coupled and backfilled with a minimum of 5 feet of backfill over the embedment. If the RCP is furnished with a plastic lining, joints shall be tested prior to welding of the liner.
3. Furnish all facilities required including necessary piping connection, test pumping equipment, pressure gauges, joint testing apparatus, regulators to avoid over pressurization, and all miscellaneous items required.
4. The joint testing apparatus shall be equipped with three taps. One tap will be used to inflate the end element sealing tubes. The second tap will be used to introduce air into the void between the sealing tubes through suitable valves and fittings, so that the input air may be regulated. The third tap will be fitted with valves and fittings to accept a pressure test gauge indicating internal pressure being applied to the pipe joint. Additional valves and fitting will be incorporated on the tap used to check internal pressure so that a second test gauge may be attached to the internal pressure tap. The pressure test gauge will also be used to indicate loss of air pressure due to leaks in the sewer line.
5. The pressure test gauge shall meet the following minimum specifications:
 - a. Size (diameter) 4-1/2 inches
 - b. Pressure Range 0-15 psi
 - c. Figure Intervals 1 psi increments
 - d. Minor Subdivisions 0.05 psi
 - e. Pressure Tube Bourdon Tube or diaphragm.
 - f. Accuracy +/-0.25% of maximum scale reading.

- g. Dial White coated aluminum with black lettering, 270° arc and mirror edge.
 - h. Pipe Connection Low male ½ inch N.P.T.
 - i. Calibration data not more than one year old shall be supplied with all pressure test gauges. Certification of pressure test gauges will be required from the gauge manufacturer. This certification and calibration data shall be given to the Engineer prior to the performance of any air tests conducted for the subject project.
6. Move the joint testing apparatus to straddle the joint. Inflate the end element sealing tubes per manufacturer's instructions. Pressurize the void volume with air to 3.5 psi. Allow the air pressure to stabilize. After the air pressure has stabilized, shut off the air supply and monitor the air pressure being applied to the joint. The pressure line shall be extended to the surface so that the pressure gauge can be monitored at the surface. If the air pressure holds, or drops less than 1 psi in 5 seconds, the joint is acceptable.
 7. If joint test fails to meet above requirements, disassemble the pipe joint to determine the cause of the failed test. Then, repeat the test as necessary after all leaks and defects have been repaired and the pipe has been backfilled.

3.11. SEWER PIPE HYDROSTATIC TESTING

With prior approval from JCW, the Contractor may use hydrostatic testing in lieu of exfiltration testing.

- A. For sewers with a diameter less than twenty-four (24) inches, the infiltration/exfiltration shall not exceed fifty (50) gallons per day per inch of nominal diameter per mile of sewer line for any section of the system. For sewers with a diameter twenty-four (24) inches or greater, infiltration/exfiltration shall not exceed three thousand six hundred (3,600) gallons per day per mile of pipe.
- B. Infiltration: Where sewers are laid within the ground water table, infiltration testing may be conducted. Where evidence of infiltration is discovered by the Engineer, the Contractor shall install weirs or other suitable flow rate measuring devices adequate to determine to the satisfaction of the Engineer that the specified infiltration limit is not exceeded for that reach of gravity sewer. Where the specified infiltration limit is exceeded, the Contractor shall repair or replace the defective reach of pipeline at no additional cost to the Owner. Following repair of the pipeline, the Contractor shall remeasure infiltration flow rates and make additional repairs until an acceptable infiltration flow rate is achieved.
- C. Exfiltration: Exfiltration tests may be performed by the Contractor using the method set forth below.
 1. Test section shall be filled not less than twelve (12) hours prior to testing. Refill test section prior to performing test.

2. Perform at depths of water as measured above center line of pipe of not less than 4 feet nor more than 10 feet (consideration shall be given for water table above said centerline). Maintain test as necessary to locate all leaks but not less than two hours.

3.12. SEWER PIPE DEFLECTION TESTING

All flexible pipelines, except ductile iron pipe, shall be tested for deflection by pulling a mandrel through the entire length thereof.

- A. The mandrel (go/no-go) device shall be cylindrical in shape and constructed with nine (9) evenly spaced arms or prongs. Mandrels with fewer arms will be rejected as not sufficiently accurate. The rigid mandrel shall have an outside diameter (O.D.) equal to 95 percent of the inside diameter (I.D.) of the pipe. The inside diameter of the pipe, for the purpose of determining the outside diameter of the mandrel, shall be the average outside diameter minus two minimum wall thicknesses for O.D. controlled pipe and the average inside diameter for I.D. controlled pipe, dimensions per appropriate standard. Statistical or other "tolerance packages" shall not be considered in mandrel sizing. The dimensions of the mandrel for PVC pipe shall be as listed in the table below. The "D" mandrel dimension shall carry a tolerance of ± 0.01 inch. Contact length (L) shall be measured between points of contact on the mandrel arm. The length shall not be less than as shown in the accompanying table.

Nominal Diameter (Inches)	"L" Mandrel Length (Inches)	"D" Mandrel Diameter (Inches)
	ASTM D3034 SDR26	
8	8	7.37
10	10	9.21
12	10	10.96
15	12	13.42
	ASTM F679 PS115	
18	18	16.49
21	21	19.44
24	24	21.87
27	27	24.65
30	24	28.21
36	24	33.78
42	24	39.24
48	24	44.80

- B. Mandrel outside diameters for HDPE and Fiberglass Wastewater Pipe shall be calculated as described in paragraph 3.11.A above. For Fiberglass Wastewater Pipe, the outside diameter of the mandrel shall be 97% of the inside diameter of the pipe.
- C. The Engineer shall be responsible for approving the mandrel. The Contractor shall provide proving rings to verify this.

- D. The mandrel shall be hand-pulled by the Contractor through all flexible sewer lines. Any sections of sewer not passing the mandrel test shall be uncovered and the Contractor, at no additional cost to the Owner, shall re-round or replace the sewer to the satisfaction of the Engineer and JCW. These repaired sections shall be retested.
- E. The testing shall be conducted after final trench backfill.

Vertical Tolerance Table Based on Slope and Length (Paragraph 3.03.B.2.b above)

Slope	MH to MH Length (Feet)	Max. Tolerance @ Upstrm. MH (Feet)	Slope	MH to MH Length (Feet)	Max. Tolerance @ Upstrm. MH (Feet)	Slope	MH to MH Length (Feet)	Max. Tolerance @ Upstrm. MH (Feet)
0.10%	50	0.01	0.35%	50	0.02	0.95%	50	0.05
0.10%	100	0.01	0.35%	100	0.04	0.95%	100+	0.10
0.10%	150	0.02	0.35%	150	0.05	1.00%	50	0.05
0.10%	200	0.02	0.35%	200	0.07	1.00%	100+	0.10
0.10%	250	0.03	0.35%	250	0.09	1.05%	50	0.05
0.10%	300	0.03	0.35%	300+	0.10	1.05%	100+	0.10
0.10%	350	0.04	0.40%	50	0.02	1.10%	50	0.06
0.10%	400	0.04	0.40%	100	0.04	1.10%	100+	0.10
0.10%	450	0.05	0.40%	150	0.06	1.15%	50	0.06
0.10%	500	0.05	0.40%	200	0.08	1.15%	100+	0.10
0.15%	50	0.01	0.40%	250+	0.10	1.20%	50	0.06
0.15%	100	0.02	0.45%	50	0.02	1.20%	100+	0.10
0.15%	150	0.02	0.45%	100	0.05	1.25%	50	0.06
0.15%	200	0.03	0.45%	150	0.07	1.25%	100+	0.10
0.15%	250	0.04	0.45%	200	0.09	1.30%	50	0.07
0.15%	300	0.05	0.45%	250+	0.10	1.30%	100+	0.10
0.15%	350	0.05	0.50%	50	0.03	1.35%	50	0.07
0.15%	400	0.06	0.50%	100	0.05	1.35%	100+	0.10
0.15%	450	0.07	0.50%	150	0.08	1.40%	50	0.07
0.15%	500	0.08	0.50%	200+	0.10	1.40%	100+	0.10
0.20%	50	0.01	0.55%	50	0.03	1.45%	50	0.07
0.20%	100	0.02	0.55%	100	0.06	1.45%	100+	0.10
0.20%	150	0.03	0.55%	150	0.08	1.50%	50	0.08
0.20%	200	0.04	0.55%	200+	0.10	1.50%	100+	0.10
0.20%	250	0.05	0.60%	50	0.03	1.55%	50	0.08
0.20%	300	0.06	0.60%	100	0.06	1.55%	100+	0.10
0.20%	350	0.07	0.60%	150	0.09	1.60%	50	0.08
0.20%	400	0.08	0.60%	200+	0.10	1.60%	100+	0.10
0.20%	450	0.09	0.65%	50	0.03	1.65%	50	0.08
0.20%	500	0.10	0.65%	100	0.07	1.65%	100+	0.10
0.25%	50	0.01	0.65%	150+	0.10	1.70%	50	0.09
0.25%	100	0.03	0.70%	50	0.04	1.70%	100+	0.10
0.25%	150	0.04	0.70%	100	0.07	1.75%	50	0.09
0.25%	200	0.05	0.70%	150+	0.10	1.75%	100+	0.10
0.25%	250	0.06	0.75%	50	0.04	1.80%	50	0.09
0.25%	300	0.08	0.75%	100	0.08	1.80%	100+	0.10
0.25%	350	0.09	0.75%	150+	0.10	1.85%	50	0.09
0.25%	400+	0.10	0.80%	50	0.04	1.85%	100+	0.10
0.30%	50	0.02	0.80%	100	0.08	All lengths of pipe with slopes of 1.9% and greater shall have no more that 0.1 feet of tolerance.		
0.30%	100	0.03	0.80%	150+	0.10			
0.30%	150	0.05	0.85%	50	0.04			
0.30%	200	0.06	0.85%	100	0.09			
0.30%	250	0.08	0.85%	150+	0.10			
0.30%	300	0.09	0.90%	50	0.05			
0.30%	350+	0.10	0.90%	100	0.09			
			0.90%	150+	0.10			

END OF SECTION 2536

SECTION 2537 - CURED-IN-PLACE PIPE (CIPP)

PART 1 GENERAL

1.01. WORK INCLUDED IN THIS SECTION

This Section governs the rehabilitation of pipelines and conduits by the installation of a resin-impregnated flexible tube, which is tightly formed to the original conduit. The resin is cured using either hot water under hydrostatic pressure or steam pressure within the tube. The Cured-In-Place Pipe (CIPP) shall be continuous and tight fitting.

1.02. SPECIFICATION MODIFICATIONS

It is understood that throughout this section these Specifications may be modified by appropriate items in the Modifications to Detailed Specifications or notes on the Contract Drawings.

1.03. REVISIONS OF STANDARDS

When reference is made to a Standard Specification i.e. ASTM, ANSI, AWWA, MCIB, the Specification referred to shall be understood to mean the latest revision of said specification as amended at the time of the Notice to Bidders, except as noted on the Drawings or in the Modifications to Detailed Specifications.

1.04. SUBMITTALS

The Contractor shall provide certifications or shop drawings on all materials provided under these specifications in accordance with the General Requirements. The Contractor shall submit the following:

- A. The Contractor shall submit to the Engineer for approval, the calculations, technical data, and complete physical properties of the liner and dimensions pertinent to the job.
- B. The Contractor shall submit a work plan to the Engineer for approval. The work plan will detail the preparation steps required for pre-installation (including methodology for point repairs), by-pass of existing flow (as defined in the General Requirements), and the procedures and steps to be followed for the installation.
- C. The Contractor shall submit to the Engineer for approval, the standard curing temperature/pressure/cool-down schedules prior to construction.
- D. The Contractor shall submit one electronic (CD) copy of all pre- and post-CCTV inspection video images and inspection logs to JCW for review and permanent record and for acceptance of work prior to final payment.

1.05. SAFETY REQUIREMENTS:

The Contractor shall complete all work in strict accordance with all applicable current OSHA, federal and state standards and requirements. Particular attention is drawn to those safety requirements involving work on an elevated platform and entry into a confined space. It shall be the responsibility of the Contractor to comply with OSHA standards and regulations pertaining to all aspects of the work.

1.06. REFERENCED DOCUMENTS

- A. This specification references standards from the American Society for Testing and Materials which are made a part hereof by such reference and shall be the latest edition and revision thereof. In case of conflicting requirements between this specification and these referenced documents, this specification will govern.
- B. The following ASTM Standards are referenced:
 - 1. ASTM F1216 - Rehabilitation of Existing Pipelines and Conduits by the Inversion and Curing of a Resin-Impregnated Tube
 - 2. ASTM D5813 - Cured-in-Place Thermosetting Resin Sewer Pipe
 - 3. ASTM D790 - Test Methods for Flexural Properties of Un-Reinforced and Reinforced Plastics and Electrical Insulating Materials, and
 - 4. ASTM D2990 - Tensile, Compressive, and Flexural Creep and Creep-Rupture of Plastics

1.07. QUALITY ASSURANCE

- A. Since sewer products are intended to have a 50-year design life, and in order to minimize JCW's risk, all trenchless rehabilitation products and installers must be pre-approved prior to performing the Work. If the product or installer does not meet the qualifications defined below, the Contractor shall provide product or installer that does meet these qualifications at no additional cost to the Owner or JCW.
- B. Products and Installers seeking approval must meet all of the following criteria to be deemed Commercially Acceptable:
 - 1. For an Installer to be considered as Commercially Proven, the Installer must satisfy all insurance, financial, and bonding requirements of the Owner, and must have been in the CIPP business for at least two (2) years. In addition, the Installer must have successfully installed at least 200,000 feet of the product bid in wastewater collection systems. The Contractor's onsite superintendents designated for this project must have had at least five (5) years of continuous active experience in the commercial installation of CIPP, and have been employed by the bidding contractor for no less than the past twelve (12) months. Acceptable documentation of these minimum installations must be submitted to the JCW.
 - 2. Sewer rehabilitation products submitted for approval must provide third party test results supporting the structural performance (short-term and long-term) of the product and such data shall be satisfactory to JCW. Test samples shall be prepared so as to simulate installation methods and trauma of the product. No product will be approved without verification.
 - 3. There must be a documented quality control and assurance program in place for the engineering applications, manufacturing, and installation.

Upon request, the Contractor shall provide the documentation verifying this requirement to JCW. JCW shall verify that the Quality Assurance program meets with their approval and is acceptable for the services provided.

4. Contractor must verify that a 24 hour response time can be met in correcting emergency repairs.
- C. Documentation: Documentation for products and installers seeking pre-approved status must be submitted no less than two weeks prior to bid date to allow time for adequate consideration. The JCW will advise of acceptance or rejection a minimum of three days prior to the bid date. All required submittals must be satisfactory to JCW.

PART 2 PRODUCTS

2.01. MATERIALS

- A. Tube: The Tube shall consist of one or more layers of absorbent non-woven or needled felt fabric and meet the requirements of ASTM F1216, Section 5.1. The tube shall be constructed to withstand installation pressures and temperatures, be compatible with the resin system used, have sufficient strength to bridge missing pipe, and stretch to fit irregular pipe sections.
- B. The wet out Tube shall have a relatively uniform thickness that when compressed at installation pressures will equal or exceed the calculated minimum design thickness.
- C. The Tube shall be manufactured to a size that when installed will tightly fit the internal circumference and length of the original pipe. Allowance should be made for circumferential stretching during inversion. Overlapped layers of felt in longitudinal seams that cause lumps in the final product shall not be utilized.
- D. The outside layer of the Tube shall be coated with an impermeable, flexible membrane that will contain the resin and will facilitate monitoring the resin impregnation (wet out) process and post-installation inspection.
- E. The Tube shall be homogeneous across the entire wall thickness containing no intermediate or encapsulated elastomeric layers. No material shall be included in the Tube that may cause delamination in the cured CIPP. No dry or unsaturated layers shall be evident.
- F. The wall color of the interior pipe surface of CIPP after installation shall be a relatively light reflective color so that a clear detailed examination with closed circuit television inspection equipment may be made.
- G. Seams in the Tube shall be as strong as or stronger than the non-seamed felt material.

- H. The Tube shall be marked for distance at regular intervals along its entire length, not to exceed 5 ft. Such markings shall include the Manufacturer’s name or identifying symbol.
- I. Resin: The resin system shall be a corrosion resistant polyester, epoxy vinyl ester, or epoxy system including all required catalysts, initiators or hardeners that when cured within the tube create a composite that satisfies the requirements of ASTM F1216 and ASTM D5813, the physical properties herein, and those which are to be utilized in the design of the CIPP for this project. The resin shall produce a CIPP that will comply with the structural and chemical resistance requirements of this specification.

2.02. STRUCTURAL REQUIREMENTS

- A. The CIPP shall be designed as per ASTM F1216, Appendix X1. The CIPP design shall assume no bonding to the original pipe wall. JCW/Engineer will determine the design condition of the pipes for this project. These calculations will define the required pipe wall thickness and are contained within the Appendix X1.
- B. The Contractor must have performed long-term testing for flexural creep of the CIPP pipe material installed by his Company. Such testing results shall be used to determine the long-term, time dependent flexural modulus shall be utilized in the product design. This is a performance test of the materials (Tube and Resin) and general workmanship of the installation and curing. A percentage of the instantaneous flexural modulus value (as measured by ASTM D790 testing) will be used in design calculations for external buckling. The percentage, or the long-term creep retention value utilized, will be verified by this testing. Retention values exceeding 50% of the short-term test results shall not be used. The materials utilized for the contracted project shall be of a quality equal to or better than the materials used in the long-term test with respect to the initial flexural modulus used in the CIPP design.
- C. The layers of the cured CIPP shall be uniformly bonded. It shall not be possible to separate any two layers with a probe or point of a knife blade so that the layers separate cleanly or the probe or knife blade moves freely between the layers. If the layers separate during field sample testing, new samples will be required to be obtained from the installed pipe. Any reoccurrence may cause rejection of the work.
- D. The cured pipe material (CIPP) shall conform to the structural properties, as listed below.

MINIMUM CIPP PHYSICAL PROPERTIES

		Cured Polyester Composite	
Property	Test Method	min. per ASTM F1216	Enhanced Resin
Flexural Modulus of Elasticity	ASTM D790	250,000 psi	400,000 psi
Flexural Strength	ASTM D790	4,500 psi	4,500 psi

- E. The required structural CIPP wall thickness shall be based as a minimum, on the physical properties in paragraph 2.02.D above and in accordance with the design equations in ASTM F1216 Appendix X1. Design Considerations of ASTM F1216 for fully deteriorated conditions, and the following design parameters:

PARAMETER	VALUE
Design Safety Factor	2.0
Retention Factor for Long-Term Flexural Modulus	As determined by long-term tests described in paragraph 2.01.B above, not to exceed 50%, and approved by JCW
Ovality	Calculated from X1.1 of ASTM F1216, and being not less than 2%
Groundwater Depth (above invert of existing pipe)	Five (5) feet below the top of ground
Soil Depth (above crown of existing pipe)	Refer to Drawings
Soil Modulus	700 psi
Soil Density	120 lb per cubic feet
Live Load	AASHTO H20 except for railroad crossings

- F. Any layers of the tube that are not saturated with resin prior to insertion into the existing pipe shall not be included in the structural CIPP wall thickness computation.

2.03. TESTING REQUIREMENTS

- A. **Chemical Resistance:** The CIPP shall meet the chemical resistance requirements of ASTM F1216, Appendix X2. CIPP samples for testing shall be of tube and resin system similar to that proposed for actual construction. It is required that CIPP samples with and without plastic coating meet these chemical-testing requirements.
- B. **Hydraulic Capacity:** Overall, the hydraulic cross-section shall be maintained as large as possible. The CIPP shall have a minimum of the full flow capacity of the original pipe before rehabilitation. Calculated capacities may be derived using a commonly accepted roughness coefficient for the existing pipe material taking into consideration its age and condition.
- C. **CIPP Field Samples:** When requested by JCW, the Contractor shall submit test results from field installations of the same resin system and tube materials as proposed for the actual installation. These test results must verify that the CIPP physical properties specified in ASTM F1216, Section 8 and have been achieved in previous field applications. Samples for this project shall be made and tested as described in paragraph 3.14 below of this specification section.

PART 3 EXECUTION

3.01. GENERAL

The Contractor shall locate all manhole access points required for executing the work. JCW will provide rights-of-access to these locations. If a street must be closed to traffic

because of the orientation of the sewer, the Contractor shall institute the actions necessary to provide access and traffic control. Contractor shall notify the appropriate city or jurisdiction with traffic control plan prior to closing or directing traffic. The Contractor shall supply water and electricity as necessary for cleaning, lining, and other work items. Contractor shall use utility approved water meters and backflow preventers before accessing a public water supply.

3.02. CLEANING OF SEWER LINES

The Contractor shall remove all internal debris and deposits out of the sewer line that will interfere with the installation of CIPP using accepted sewer cleaning techniques. The Contractor shall dispose of all debris removed from the sewers during the cleaning operation. Any hazardous waste material encountered during this project will be considered as a changed condition and Owner and JCW must be notified before any actions are taken to remove or dispose of hazardous waste.

3.03. BYPASSING SEWAGE

The Contractor, when required, shall provide for the flow of sewage around the section or sections of pipe designated for repair. Plugging the line at an existing upstream manhole and pumping the flow into a downstream manhole or adjacent system shall make the bypass. The pump(s) and bypass line(s) shall be of adequate capacity to accommodate the sewage flow. All bypass lines shall be of appropriate quality and free of leaks. Any defective bypass hose shall be replaced when leaks are noted. The Contractor shall submit a detail of the bypass plan to JCW.

3.04. INSPECTION OF PIPELINES

Inspection of pipelines shall be performed by experienced personnel trained in locating breaks, obstacles and service connections using close circuit television (CCTV) PACP certified inspection techniques. All Pre Liner & Post Liner CCTV shall be PACP rated. The pipeline interior shall be carefully inspected to determine the location of any conditions that may prevent proper installation of CIPP. These shall be noted and corrected. The video images shall be recorded electronically on a CD and provided to JCW along with suitable written logs for each line section for later reference by JCW.

3.05. LINE OBSTRUCTIONS

It shall be the responsibility of the Contractor to clear the line of obstructions such as solids and roots that will prevent the insertion of CIPP. If pre-installation inspection reveals an obstruction such as a protruding service connection, dropped joint, or a collapse that will prevent the installation process, that was not evident on the pre-bid video and it cannot be removed by conventional sewer cleaning equipment, then the Contractor shall make a point repair excavation to uncover and remove or repair the obstruction. Such excavation shall be approved in writing by the Owner's representative prior to the commencement of the work and shall be considered as a separate pay item.

3.06. PUBLIC NOTIFICATION

The Contractor shall make every effort to maintain sewer service usage throughout the duration of the project. In the event that a connection will be out of service, the longest period of no service shall be eight (8) hours. A public notification program shall be implemented, and shall as a minimum, require the Contractor to be responsible for contacting each home or business connected to the sanitary sewer and informing them

of the work to be conducted, and when the sewer will be off-line. The Contractor shall also provide the following:

- A. Written notice to be delivered to each home or business three days prior to the beginning of work being conducted on the section, and a local telephone number of the Contractor they can call to discuss the project or any potential problems. The office number of the appropriately identified JCW representative shall also be included on this notice.
- B. Personal contact must be conducted with any home or business which cannot be reconnected within the time stated in the written notice.

3.07. SERVICE CONNECTIONS

The Contractor shall be responsible for confirming the locations of all branch service connections prior to installing the CIPP.

3.08. HANDLING

The Manufacturer and Contractor shall use equipment and methods adequate to protect the pipe, joint elements and prevent shock contact of adjacent units during moving or storage. Damaged sections that cause reasonable doubt as to their structural strength or water-tightness will be rejected.

3.09. YARD PROTECTIVE MEASURES

The Contractor shall provide protective measures (felt, blocks of wood, plywood, cardboard, concrete blocks, street plates, etc.) to create a barrier between the boiler/steam hoses and grass for each installation.

3.10. INSTALLATION

The Contractor shall allow JCW to inspect the materials and "wet out" procedure. The lining shall be impervious and free of any leakage from the pipe to the surrounding ground or from the ground to the inside of the lined pipe. CIPP installation shall be in accordance with ASTM F1216, Section 7.

- A. Resin Impregnation: The quantity of resin used for tube impregnation shall be sufficient to fill the volume of air voids in the tube with additional allowances for polymerization shrinkage and the loss of resin during installation through cracks and irregularities in the original pipe wall.
- B. If a vacuum impregnation process is used, the point of vacuum shall be no further than 25-feet from the point of initial resin introduction. After vacuum in the tube is established, a vacuum point shall be no further than 75-feet from the leading edge of the resin. The leading edge of the resin slug shall be as near to perpendicular to the longitudinal axis of the tube as possible. A roller system shall be used to uniformly distribute the resin throughout the tube. If the Installer uses an alternate method of resin impregnation, the method must produce the equivalent results. Any alternate resin impregnation method must be documented to JCW's satisfaction that the saturation of the CIPP is sufficient.
- C. Tube Insertion: The wet out tube shall be positioned in the pipeline using water or steam inversion only. The tube should be inverted through an existing

manhole or approved access point and fully extended to the next designated manhole or termination point.

- D. Temperature gauges shall be placed between the tube and the host pipe's invert position to monitor the temperatures during the cure cycle.
- E. Curing shall be accomplished by utilizing hot water under hydrostatic pressure or steam pressure in accordance with the manufacturer's recommended cure schedule.
- F. The Contractor shall cool the hardened pipe to a temperature below 100 degrees Fahrenheit (or as recommended by the manufacturer), before relieving the water column. Cool water may be added to the column while draining hot water from a small hole at the opposite end of the CIPP, so that a constant water column height is maintained until cool-down is completed. Care shall be taken in the release of the water column so that a vacuum will not be developed that could damage the newly installed liner.
- G. The finished CIPP shall be continuous over the entire length from manhole to manhole and be free from visual defects such as foreign inclusions, dry spots, keel, boat hull, pinholes, wrinkles and other deformities. Any defects, which will affect the integrity or strength of the pipeliner, discovered in the post-installation inspection and during the warranty period shall be repaired at the Contractor's expense.
- H. The CIPP shall make a tight fitting seal with the existing pipe(s) in the manhole. One-half inch (1/2") diameter activated oakum band soaked in Scotch Seal 5600 or equal shall be applied circumferentially near the annular space touching the end of the existing pipe and properly encased with a cement based mortar. The top half of the pipeliner shall be neatly cut off at least two inches (2") away from the walls. Breaking or shearing of the pipeliner will not be allowed. The channel in the manhole shall be a smooth continuation of the pipe(s) and shall be merged with other lines or channels, if any. The sides of the channels shall be built up with mortar/concrete to provide benches at a maximum of 1 in 12 pitch towards the channel.

3.11. SEALER LINER AT ENDS

If due to a broken or misaligned pipe at the access point, the lining fails to make a tight seal, the Contractor shall apply a seal at that point. The seal shall be of a resin mixture compatible with the liner.

3.12. LINER TRIMMING

After the liner has been cured, the liner should be trimmed entering and exiting the manhole, so that it is nearly flush with the manhole wall. For each inversion of two (2) or more line segments using a single liner, the liner should be cut flush with the trough at the intermediate manhole(s). If additional line segments enter these intermediate manhole(s), the liner should not obstruct the flow from these lines.

3.13. REINSTATEMENT OF BRANCH CONNECTIONS

It is the intent of these specifications that branch connections to buildings be re-opened without excavation, utilizing a remotely controlled cutting device, monitored by a CCTV.

The Contractor shall certify a minimum of two complete functional cutters plus key spare components are on the job site before each installation or are in the immediate area of the jobsite and can be quickly obtained. Unless otherwise directed by JCW or his authorized representative, all laterals will be reinstated to not less than 90 percent capacity. No additional payment will be made for excavations for the purpose of reopening connections. The Contractor will be responsible for all costs and liability associated with such excavation and restoration work.

3.14. INSPECTION

- A. CIPP samples shall be prepared and physical properties tested in accordance with ASTM F1216. The flexural properties must meet or exceed the values listed in paragraph 2.02.D above.
- B. Wall thickness of samples shall be determined as described in Section 8 of ASTM F1216. The minimum wall thickness at any point shall not be less than the minimum design wall thickness as calculated in ASTM F1216.
- C. Visual inspection of the CIPP shall be in accordance with ASTM F1216, Section 8.7.

3.15. TELEVISION INSPECTION OF GRAVITY SEWER 8-INCH IN DIA. AND LARGER

A high quality project video recording of internal conditions of gravity sewer 8-inch in diameter and larger shall be created in accordance with SECTION 1400 - PROJECT INTERNAL TELEVISION INSPECTION after construction is complete.

3.16. CLEAN-UP

Upon acceptance of the installation work and testing, the Contractor shall restore the project area affected by the operations to a condition at least equal to that existing prior to the work.

3.17. WARRANTY

All liner installations shall be warranted to be free from defects in material and workmanship for a period of three (3) years from the date of project acceptance. Should a defect occur during this three (3) year period that is attributable to the liner installation or materials, then this defect shall be repaired within four (4) weeks from the date of defect notification to the Contractor at no additional cost to the Owner or JCW. However; if a liner is causing loss of flow or causing a backup the contractor will repair within 24 hours. The Contractor shall be responsible for all required repair costs associated with a liner failure during the warranty period including all costs associated with lateral backups into buildings and all other property damage.

END OF SECTION 2537

SECTION 2538 - PIPE BURSTING/REAMING

PART 1 GENERAL

1.01. WORK INCLUDED IN THIS SECTION

This section governs all work, materials and testing for installation of pipe by trenchless method of bursting or reaming existing pipes as shown on the plans and in conformity with these specifications. The operation shall be conducted with a pulling or pushing apparatus and a pipe shield/expander/reamer. The pipe expander/reamer shall be pushed or pulled through the existing pipe on grade, widening the existing pipe material for insertion of the new pipe material.

1.02. SPECIFICATION MODIFICATIONS

It is understood that throughout this section these Specifications may be modified by appropriate items in the Modifications to Detailed Specifications or notes on the Contract Drawings.

1.03. REVISIONS OF STANDARDS

When reference is made to a Standard Specification i.e. ASTM, ANSI, AWWA, MCIB, the Specification referred to shall be understood to mean the latest revision of said specification as amended at the time of the Notice to Bidders, except as noted on the Drawings or in the Modifications to Detailed Specifications.

1.04. SUBMITTALS

The Contractor shall provide certifications or shop drawings on all materials provided under these specifications in accordance with the General Requirements. The Contractor shall submit the following:

- A. Shop drawings, catalog data, and manufacturer's technical data showing complete information on material composition, physical properties, and dimensions of new pipe and fillings. Include manufacturer's recommendations for handling, storage, and repair of pipe and fillings damaged.
- B. Certification of workmen training for installing pipe.
- C. The Contractor shall submit a work plan to the Engineer for approval. The work plan will detail the method of construction with detailed drawings and written descriptions of the entire construction procedure to insert the pipe, pipe fusion techniques, non-fusion pipe joining techniques, and reestablishment of lateral connections. The Contractor submitted drawings shall show, but are not limited to, excavation locations, access pits, dimensions, shoring, dewatering method, adjacent utilities, traffic control, and the by-pass of existing flow (as defined in the General Requirements).

1.05. REFERENCED DOCUMENTS

- A. This specification references standards from the American Society for Testing and Materials which are made a part hereof by such reference and shall be the latest edition and revision thereof. In case of conflicting requirements between this specification and these referenced documents, this specification will govern.

- B. The following standard specifications are referenced:
1. ASTM D2241: Standard Specification for Poly (Vinyl Chloride) (PVC) Pressure-Rated Pipe (SDR Series)
 2. ASTM D2657: Standard Practice for Heat Fusion Joining of Polyolefin Pipe and Fittings
 3. ASTM D2837: Standard test method for Obtaining Hydrostatic Design Basis for thermoplastic Pipe Materials or Pressure Design Basis for Thermoplastic Products
 4. ASTM D3350: Standard Specification for Polyethylene Plastics Pipe and Fittings Materials
 5. ASTM F477: Standard Specification for Elastomeric Seals (Gaskets) for Joining Plastic Pipe
 6. ASTM F714: Polyethylene (PE) Plastic Pipe (SDR-PR) Based on Outside Diameter

1.06. QUALIFICATIONS

- A. The contractor shall be certified by the particular Pipe Bursting System Manufacturer that such a company is a fully trained user of the pipe bursting or reaming system.
- B. Polyethylene pipe jointing shall be performed by personnel trained in the use of bull-fusion equipment and recommended methods for new pipe connections. Personnel directly involved with installing the new pipe shall receive training in the proper methods for handling and installing the polyethylene pipe. Training shall be performed by qualified representative.
- C. The Contractor shall hold JCW and Engineering Consultant held harmless in any legal action resulting from patent infringements. The Contractor shall be licensed by British Gas pipe bursting patents which are available from British Gas or by Nowak Pipe Reaming, Inc. for pipe reaming patents which are available from Nowak Pipe Reaming, Inc.
- D. The contractor shall have experience installing line using pipe bursting or reaming, with a minimum of 25,000 feet in installations.

PART 2 PRODUCTS

2.01. GENERAL

This section governs materials that may be required to complete pipe installation by trenchless pipe replacement methods as shown on the Drawings and/or as provided for in the Specifications.

2.02. HIGH DENSITY POLYETHYLENE (HDPE) PIPE

HDPE pipe for trenchless sewer line installation shall be solid wall high density polyethylene (HDPE) pipe, meeting the requirements of ASTM F714, ASTM D1248, and ASTM D3350.

- A. General: Furnish maximum pipe lengths normally produced by the manufacturer, except for fittings, closures and specials.
- B. Materials: The pipe shall be made of Type 3408 HDPE pipe having a cell classification of PE 345434B or higher as defined in ASTM D3350. The pipe shall have an established hydrostatic design basis (HDB) of not less than 1,600 psi for water at 73.4 ° F. in accordance with ASTM D2837.
- C. Design: The pipe shall have sufficient strength to withstand both installation and service loads. The pipe shall have a minimum wall thickness conforming to SDR 17 (IPS - OD). The HDPE pipe wall thickness shall be as shown on the Drawings.
- D. Joints: The pipe shall be butt-fused and tested in accordance with manufacturer recommendations and applicable provisions of ASTM D2657.
- E. Fittings: All fittings shall conform to the requirements of ASTM F714 and be joined to the pipe as recommended by the pipe manufacturer. High density polyethylene pipe and fittings shall be supplied from the same manufacturer. Pipe and fittings shall be manufactured from the same materials and shall carry the same pressure rating The manufacturer shall provide a certificate of compliance certifying that the materials used to manufacture pipe and fittings meet the requirements of these specification.
- F. The pipe and fitting manufacturer shall certify that samples of his production pipe have undergone stress regression testing, evaluation, and validation in accordance with ASTM D2837 and PPI TR-3. Under these procedures, the minimum hydrostatic design basis shall be certified by the pipe manufacturer to be 1600 psi at 73.4°F and 800 psi at 140°F.
- G. Polyethylene pipe color should be a gray, white, or similar light color to enhance visibility during internal TV inspection of the pipe. HDPE with Opti-core liner inside the pipe is an acceptable alternate to colored pipe.

2.03. PVC PIPE

Certa-Lok YELOMINE restrained Joint PVC Pressure Pipe or equal shall meet the requirements of ASTM D2241. The pipe shall be joined using separate couplings that have beveled edges, built-in sealing gaskets, and restraining grooves. The restraining splines shall be hydrostatically tested at the factory at four times its rated pressure for at least five seconds.

- A. Design: The pipe shall have sufficient strength to withstand both installation and service loads. The pipe shall have a minimum wall thickness conforming to SDR 26 with a minimum working pressure rating of 160 psi. The Certa-Lok YELOMINE pipe wall thickness shall be as shown on the Drawings.
- B. Materials:

1. The pipe shall be made of PVC plastic having a minimum cell classification of 12454-B as defined in ASTM D1784. The pipe materials shall have a minimum hydrostatic design stress of 4,000 psi at 73.4° F per the requirements of PPI TR-3 as issued by the Plastic Pipe Institute. Additives and fillers including but not limited to stabilizers, antioxidants, lubricants, colorants, etc., shall not exceed 20 parts by weight per 100 of PVC resin in the compound. The compounding ingredients may consist of lubricants, stabilizers, non polyvinyl chloride resin modifiers, and pigment essential for processing, property control, and coloring. Certification of resin compounding shall be provided by the pipe manufacturer prior to shipment to the job site.
 2. One test to verify resin compounding may be required by the Engineer and/or JCW. The test shall be performed by an independent testing laboratory approved by JCW and shall be performed upon a sample of pipe obtained from the job site. The cost of the test shall be paid for by the Contractor and shall be included with the bid price for pipe. The test shall be performed in accordance with ASTM D2584 Standard Test Method for Ignition Loss of Cured Reinforced Resins.
- C. O-rings shall meet the requirements of ASTM F477.

PART 3 EXECUTION

3.01. INSTALLATION

- A. **Safety:** The contractor shall carry out his operations in strict accordance with all OSHA and manufacturers' safety requirements. Particular attention is drawn to those safety requirements involving entering confined spaces.
- B. The Contractor shall protect structures, pavement, facilities and other utilities from damage by forces generated by the pipe bursting equipment. If damage occurs, the Contractor shall repair or replace the damaged structure, pavement, facility, or utility to its owner's satisfaction, prior to demobilizing from the site.
- C. The Contractor shall establish heave/settlement points at locations agreed to with the Engineer and JCW prior to beginning the bursting or reaming operations. The Contractor shall record elevations at heave/settlement points prior to and after pipe bursting or reaming and submit a log of elevations and changes in elevation.
- D. **Pre-Installation Television Inspection:** It shall be the responsibility of the Contractor to video (TV) inspect the sewer pipe immediately before pipe bursting or reaming to assure that the existing pipe conditions are acceptable for pipe bursting or reaming, and to locate all active service line connections. Television inspection shall be performed in accordance with SECTION 1400 - PROJECT INTERNAL TELEVISION INSPECTION.
- E. **Sewage Bypass:** When required for acceptable completion of pipe bursting or reaming, the Contractor shall provide for continuous sewage flow around the section(s) of pipe designated for the installation of replacement pipe. The bypass

pumping of wastewater shall meet the requirements of the General Requirements.

- F. Sags In Line: If Pre-Installation video (TV) inspection reveals a sag in the existing sewer that is greater than one-half the diameter of the existing pipe and continues for more than 3 joints, the Engineer may direct the Contractor to open cut a sag elimination pit to install the new pipe at a uniform grade. This work, if directed by the Engineer, would require a change order.
- G. The Contractor shall install all pulleys, rollers, bumpers, alignment control devices and other equipment required to protect existing facilities and to protect the pipe from damage during installation. Lubrication may be used as recommended by the manufacturer. Under no circumstances shall the pipe be stressed beyond the elastic limit defined by the pipe manufacturer.
- H. Service Laterals and Connections
 - 1. Existing service connections shall be located before initiating sewer main replacement operations. The Contractor shall also be responsible for temporary suspension and restoration of sewer service along with property owner notification for all facilities affected.
 - 2. Service laterals shall not be reconnected to the new sewer line until the new line is installed. Any services remaining off line for an extended period of time, or any connections as deemed necessary by the Engineer to protect the customer, shall be bypass pumped until such time that they can be reconnected.
 - 3. Reconnection of service laterals to the installed sewer main pipe shall be accomplished using one of two approved methods:
 - a. Saddles: Heat fusion saddles shall be made of polyethylene pipe that is suitable for fusion welding. Fusion saddles shall be Branch Saddle as manufactured by Driscopipe, Miller, DuPont, or approved equal.
 - b. Watertight compression-fit service connection: The connection shall be specifically designed for connection to the HDPE sewer main being installed, and shall be INSERTA TEE as manufactured by Fowler Manufacturing Co., Hillsboro, Oregon, or approved equal.
 - 4. Connections to existing service laterals shall be made using flexible couplings. All flexible couplings shall conform to ASTM C425 and shall be as manufactured by Fernco Joint Sealer Co., DFW Plastics, Inc., or approved equal.

3.02. PIPE JOINING

The polyethylene pipe shall be assembled and joined at the site using the butt-fusion method to provide a leak proof joint. Threaded or solvent-cement joints and connections are not permitted. All equipment and procedures used shall be used in strict compliance with the manufacturer's recommendations. Fusing shall be accomplished by personnel

certified as fusion technicians by a manufacturer of polyethylene pipe and/or fusing equipment.

- A. The butt-fused joint shall be true alignment and shall have uniform roll-back beads resulting from the use of proper temperature and pressure. The joint shall be allowed adequate cooling time before removal of pressure. The fused joint shall be watertight and shall have tensile strength equal to that of the pipe. All joints shall be subject to acceptance by the Engineer and/or his representative prior to insertion. All defective joints shall be cut out and replaced at no cost to the Owner. Any section of the pipe with a gash, blister, abrasion, nick, scar, or other deleterious fault greater in depth than ten percent (10%) of the wall thickness, shall not be used and must be removed from the site. However, a defective area of the pipe may be cut out and the joint fused in accordance with the procedures stated above. In addition, any section of the pipe having other defects such as concentrated ridges, discoloration, excessive spot roughness, pitting, variable wall thickness or any other defect of manufacturing or handling as determined by the Engineer and/or his representative shall be discarded and not used.
- B. Where excavations for the insertion of the replacement pipe are made between two manholes, the ends of the pipe will be cut smooth and square to the axis so that it can be joined in a workman like manner such that the gap between pipe ends does not exceed one-half ($\frac{1}{2}$) inch. A Fernco coupling or a full circle repair clamp with a minimum width of 12 inches (Smith-Blair or approved equal) shall be used. The butt-fusion method of pipe joining may be used as well.
- C. Certa-Lok YELOMINE pipe shall be joined and assembled as recommended by the manufacturer of the pipe. Contractor shall refer to CertainTeed Technical Bulletin No. 40-90-17 for assembly and installation instructions.
- D. Internal Bead Removal
 - 1. All internal beads shall be removed after the cooling time using a suitable bead removal tool. The bead removal tool shall not induce any slits, gouges or defects in the pipe wall.
 - 2. The beads shall be bent back at several positions. No evidence of the bead splitting shall be seen. If the bead is seen to split at any point then the joint shall be cut from the pipeline and remade. If a similar defect recurs, all further production jointing shall cease until the equipment has been thoroughly cleaned and examined. New trial joints shall be made and shown to be satisfactory.
- E. Pipe Relaxation and Cooling: The installed pipe shall be allowed to cool down for an amount of time recommended by the manufacturer, but not less than four (4) hours, prior to any reconnection of service lines, sealing of the annulus or backfilling of the insertion pit. Sufficient excess length of new pipe, but not less than twelve (12) inches, shall be allowed to protrude into the manhole.
- F. Sealing: The replacement pipe shall be installed with a tight fitting seal with the existing or new manhole. A WS-30 Waterstop by Press-Seal Gasket Co. or approved equal shall be placed circumferentially on the replacement pipe and

encased with a cementitious non-shrink grout to prevent inflow at the manhole. A PSX Boot gasket, by Press-Seal Gasket Co. may be used if the manhole wall has been cored to provide a surface capable of a water-tight seal between the boot gasket and the manhole wall.

- G. Installation Procedure: The Contractor shall carefully follow the approved installation procedures as submitted. Any proposed changes in installation procedures shall require submittal of revised procedures and acceptance by the Engineer.
- H. Testing: Testing of sanitary sewer lines for water tightness and structural integrity following installation of main lines, manhole connections, and house service connection renewals shall be as specified in SECTION 2536 - SEWER PIPE INSTALLATION and in SECTION 2539 - TESTING LABORATORY SERVICES. Internal video inspection shall be performed in accordance with SECTION 1400 - PROJECT INTERNAL TELEVISION INSPECTION.
- I. Extreme Deflection: If Post-Installation video (TV) inspection reveals extreme deflection in the new HDPE pipe, the Engineer may direct the Contractor to excavate and expose the point(s) of extreme deflection and resolve the physical feature(s) that is causing the extreme deflection. This work, if directed by the Engineer, would require a change order.

3.03. WARRANTY

All installations shall be warranted to be free from defects in material and workmanship for a period of three (3) years from the date of project acceptance. Should a defect occur during this three (3) year period that is attributable to the liner installation or materials, then this defect shall be repaired within four (4) weeks from the date of defect notification to the Contractor at no additional cost to the Owner. The Contractor shall be responsible for all required repair costs associated with a failure during the warranty period including all costs associated with lateral backups into buildings and all other property damage.

END OF SECTION 2538

SECTION 2539 - TESTING LABORATORY SERVICES

PART 1 GENERAL

1.01. WORK INCLUDED IN THIS SECTION

- A. Provide testing and inspecting as specified to be furnished by the Contractor elsewhere in these Specifications. The Contractor is referred to the following sections for required testing:

Test	Technical Specification Section
Soil Density Tests	Section 2315 - Trenching And Backfilling
Manhole and Structure Testing	Section 2530 - Manholes And Special Structures
Bedding Aggregate Testing	Section 2536 - Sewer Pipe Installation
Visual Internal Inspection	Section 2536 - Sewer Pipe Installation
Sewer Pipe Exfiltration Testing	Section 2536 - Sewer Pipe Installation
Pipe Deflection Testing	Section 2536 - Sewer Pipe Installation
Concrete Sampling And Testing	Section 3000 - Cast-In-Place Concrete

- B. The Contractor shall select a qualified independent testing laboratory which is subject to the review of the Engineer and JCW.
- C. Where no testing requirements or standards are described, but JCW decides that testing is required, JCW may direct that such testing be performed under current standards for testing. Payment for such testing will be made as described in this Section.
- D. Where the requirements of the jurisdictional agency are more stringent or require tests not defined in these Technical Specifications, the Contractor shall also provide those tests to the satisfaction of the jurisdictional agency, and the costs of those tests shall be included in the Contractors bid and shall be subsidiary to other costs.

1.02. SPECIFICATION MODIFICATIONS

It is understood that throughout this section these Specifications may be modified by appropriate items in the Modifications to Detailed Specifications or notes on the Contract Drawings.

1.03. REVISIONS OF STANDARDS

When reference is made to a Standard Specification i.e. ASTM, ANSI, AWWA, MCIB, the Specification referred to shall be understood to mean the latest revision of said specification as amended at the time of the Notice to Bidders, except as noted on the Drawings or in the Modifications to Detailed Specifications.

1.04. SUBMITTALS

The Contractor shall provide certifications or shop drawings on all materials provided under these specifications in accordance with the General Requirements.

1.05. PRODUCT HANDLING

Promptly process and distribute required copies of test reports and related instructions to ensure necessary retesting and replacement of materials with the least possible delay in progress of the Work.

PART 2 PRODUCTS

2.01. PAYMENT FOR TESTING

- A. When the Contractor is directed to conduct tests other than those required in the specifications, the Owner shall pay the full cost of conducting the test when the material meets or exceeds the specified test requirements. If the test yields a failing result, the Contractor shall pay for the testing.
- B. The tests specified in the Contract Documents, Drawings, or Project Specifications shall be paid for by the Contractor.
- C. Retesting: When tests indicate non-compliance with the Contract Documents, all subsequent retesting occasioned by the non-compliance shall be performed by the same testing agency and the costs thereof will be paid for by the Contractor.
- D. Code Compliance Testing: Inspections and tests required by codes or ordinances, or by a plan approval authority, and which are made by a legally constituted authority, shall be the responsibility of and shall be paid for by the Contractor, unless otherwise provided in the Contract Documents.
- E. Contractor's Convenience Testing: Inspecting and testing performed exclusively for the Contractor's convenience shall be the sole responsibility of the Contractor.

PART 3 EXECUTION

3.01. GENERAL

The Contractor shall furnish all labor, equipment, materials and reports for the required acceptance tests. All pipelines, including building service lines shall undergo and pass tests to determine the soundness and workmanship regarding alignment, grade, infiltration, exfiltration and/or pressure. Pipelines which do not conform to the project requirements shall be repaired and/or replaced and shall be retested until the pipeline meets the project requirements. Test results shall be collected by the Contractor and a copy shall be submitted to the Engineer and JCW. No testing shall be performed before backfill and compaction operation has been completed. Exfiltration testing and deflection testing shall be performed in the presence of a JCW inspector. The Contractor shall notify the Engineer and the JCW inspector at least 24 hours prior to the start of testing, and testing shall be scheduled only between the hours of 9:30 a.m. and 4:00 p.m. on weekdays (but never on official County holidays). Retesting required as a result of Contractor's failure to conform to these requirements shall be a subsidiary obligation of the Contractor.

3.02. COOPERATION WITH TESTING LABORATORY

Representatives of the testing laboratory shall have access to the Work at all times. Provide facilities for such access in order that the laboratory may properly perform its function.

3.03. TAKING SPECIMENS

Specimens and samples for testing, unless otherwise provided in the Contract Documents, will be taken by the testing personnel. Sampling equipment and personnel will be provided by the testing laboratory. Deliveries of specimens and samples to the testing laboratory will be performed by the testing laboratory.

3.04. SCHEDULE

A. Establishing the Schedule:

1. The Contractor shall coordinate with the testing laboratory and determine the time required for the laboratory to perform its tests and to issue each of its findings.
2. The Contractor shall provide required time within the construction schedule.

B. Revising the Schedule: When changes of construction schedule are necessary during construction, the Contractor shall coordinate such changes of schedule with the testing laboratory as required.

C. Adherence to schedule: When the testing laboratory is ready to test according to the established schedule, but is prevented from testing or taking specimens due to incompleteness of the Work, all extra charges for testing attributable to the delay may be back-charged to the Contractor and shall not be borne by the Owner.

3.05. ALTERNATIVE INSPECTION PROCEDURE

The Engineer or JCW shall have the right to require alternative inspection procedure other than as specified when, in the Engineer's judgment, other inspections are required to demonstrate compliance with the Contract requirements. Costs of such alternative inspections will be borne by the Owner if products are found to comply; otherwise, costs shall be borne by the Contractor.

END OF SECTION 2539

SECTION 2920 - RESTORATION

PART 1 GENERAL

1.01. WORK INCLUDED IN THIS SECTION

This Section governs the furnishing all labor, equipment, and materials required for surface restoration of land disturbed by sanitary sewer construction.

1.02. SPECIFICATION MODIFICATIONS

It is understood that throughout this section these Specifications may be modified by appropriate items in the Modifications to Detailed Specifications or notes on the Contract Drawings.

1.03. REVISIONS OF STANDARDS

When reference is made to a Standard Specification i.e. ASTM, ANSI, AWWA, MCIB, the Specification referred to shall be understood to mean the latest revision of said specification as amended at the time of the Notice to Bidders, except as noted on the Drawings or in the Modifications to Detailed Specifications.

1.04. SUBMITTALS

The Contractor shall provide certifications or shop drawings on all materials provided under these specifications in accordance with the General Requirements. The Contractor shall submit the following:

- A. General. The Contractor shall provide all certifications or shop drawings required under these Specifications prior to commencing with the seeding or sodding operation. Work done prior to the Engineer's review of the submittals will be considered unacceptable and shall be removed at the sole cost of the Contractor.
- B. Seed Labels. All state seed certification tags and seed analysis labels shall be submitted to the Engineer for acceptance.
- C. Mulch. A full product fact sheet from the manufacturer shall be submitted to the Engineer for acceptance. A weight certificate for each load of mulch to be used shall be submitted to the Engineer. The certificate shall be used to verify application rates.
- D. Sod Grower. The sod grower's name and address and a sod analysis substantiating that the material complies with specified requirements shall be submitted. The Engineer reserves the right to inspect the sod at the place of growth for compliance with variety and quality.
- E. Experience. A listing of seeding or sodding projects completed and the name, address, and telephone number of the owner of those projects.

1.05. DESCRIPTION

- A. The Contractor shall restore the project site to conditions equal to or better than those existing prior to entry. All existing items and construction removed or damaged during the performance of work, regardless of location and whether or

not indicated on the Drawings, shall be repaired or replaced unless otherwise indicated on the Drawings. Repair or replacement shall be done with materials similar to those existing and shall, in each case, restore the item to its original or better quality, thickness, and appearance as acceptable to the Engineer and the owner thereof.

- B. All public and private grass lawns disturbed by construction operations shall be sodded in accordance with the Contract Documents or as noted on the Drawings. Pastures, wooded areas, or other vegetated areas disturbed by construction operations shall be seeded in accordance with the Contract Documents or as noted on the Drawings.
- C. Contractor shall coordinate surface restoration with the affected property owners.
- D. The Contractor shall maintain adequate safety signs, barricades and lights until final restoration of work area is completed.
- E. Public property shall be restored to the requirements of the public body having jurisdiction. The contractor shall be responsible for coordinating with each city, county or any other authority having jurisdiction regarding their requirements. The public agency's requirement shall govern except that materials and workmanship shall not be less than required by the Drawings and Specifications.

1.06. PERSONNEL AND EQUIPMENT

- A. All seeding and sodding work shall be performed by a subcontractor who is a landscaping or lawn and garden contractor regularly engaged in seeding and sodding work and having personnel who are experienced and qualified in the work required. The subcontractor shall be approved by the Engineer prior to the start of the work.
- B. Seeding shall be accomplished with equipment suitable for preparing the seed bed, sowing the seed, fertilizing, and mulching in accordance with the applicable requirements of this section. On small areas and areas too steep for the safe operation of conventional seeding equipment, the subcontractor shall use mechanical hand seeders.
- C. Equipment necessary for the proper preparation of the ground surface and for handling and placing all required materials shall be of a size appropriate for work area and shall be in good condition

1.07. GUARANTEE

The Contractor shall unconditionally guarantee until acceptance by JCW a stand of grass in seeded and sodded areas that 1) has a fully established root system, 2) is thoroughly knitted, 3) is uniform in color, overall texture, and density, and 4) is reasonably free of weeds, diseases, or other visible imperfections. As a minimum requirement, all seeded and sodded areas must be equal to or better than adjacent, undisturbed areas. The work will not be accepted and final payment will not be made until a uniform and full stand of grass acceptable to JCW is obtained.

PART 2 PRODUCTS

2.01. TOPSOIL

- A. When the topsoil is placed for use, it shall be free from tree roots, clay balls, 1-inch diameter and greater stones, and other materials that hinder grading, planting, and maintenance operations and shall be free from noxious and other objectionable weed seeds and toxic substances.
- B. As defined in paragraph 3.02.G of this Section, additional topsoil shall be provided by the Contractor at no additional cost to the Owner if the Contractor fails to stockpile a sufficient quantity of topsoil or if a sufficient quantity of existing topsoil is not available. Imported topsoil shall be a loamy mixture having at least 90 percent passing the No. 10 sieve, and shall comply with the following requirements:
 - 1. Contain not less than 3.0 percent organic matter as determined by the test for organic matter in accordance with AASHTO T194.
 - 2. Contain not less than 12 percent clay as determined in accordance with AASHTO T88.
 - 3. Sand content shall not exceed 55 percent as determined in accordance with AASHTO T88.
 - 4. The pH of the sample shall not be lower than 5.0 or higher than 8.0. The pH shall be determined with a calibrated pH meter, on that portion of the sample passing the No. 10 sieve in accordance with the "Suggested Methods of Test for Hydrogen Ion Concentration (pH) of Soils" included in the procedures for Testing Soil issued in 1970, by ASTM.

2.02. WATER

Water used in this work shall be furnished by the Contractor and shall be suitable for irrigation and free from ingredients harmful to plant life. All watering equipment required for the work shall be furnished by the Contractor. Water from adjacent fire hydrants or public water lines shall be metered. Meters shall be inspected and approved by the city, utility, or other authority having jurisdiction. Backflow prevention shall be provided as required. Written approval from the property owner shall be obtained prior to the use of suitable water from ponds or creeks.

2.03. SEED

Seeds for cover crops shall comply with the requirements of applicable state seed laws. Seeds shall be free of prohibited weed seeds and shall not have more than one (1) percent of noxious weed seeds. Seeds shall be delivered to the site in convenient containers, each fully labeled, bearing name, trade name, or trade mark, and a warranty of the producer and a certificate of the percentage of purity and germination of each kind of seed within the container. The containers shall also bear date of last germination which shall be within six (6) months prior to planting. Seed which has become wet, moldy, or otherwise damaged in transit or storage will not be accepted.

- A. General Grass Seed (Type "A"): Unless specified otherwise, this seeding mixture will be used where seeding is required in areas of established yards, on

shoulders and slopes in street right-of way, and any other areas where a high-type or lawn seeding is deemed necessary. The seed mixture will be a 100% Turf-Type Tall Fescue composed of an equal mix of three or four compatible species. The mixture shall not include any varieties of the slower growing Turf-Type Tall Fescue “Dwarf”. The species shall be one of the following as recommended by Johnson County K-State Research and Extension Office:

Apache III	Avenger	Blackwatch	Blade Runner
Bullseye	Cayenne	Cezanne Rz	Cochise III
Constitution	Coyote	Dynasty	Einstein
Escalade	Falcon IV	Finelawn Elite	Firenza
Grande II Masterpiece	Hemi	Hunter	Justice
Laramie	Lexington	Millennium	Monet
Padre	Picasso	Rebel IV	Rembrandt
Riverside	Scorpion	2nd Millennium	Serengeti
Silverado II	Speedway	Titanium	Turbo
Tulsa III	Ultimate	Van Gogh	Wolfpack

1. The seed mixture shall also include 100% Annual Rye grass to provide a temporary grass stand. The seed shall be sowed at a rate of 10 pounds per 1,000 square feet of the Turf-Type Tall Fescue and 2 pounds per 1,000 square feet of the Annual Rye.

B. General Grass Seed (Type “B”): This seeding mixture will normally be used to seed areas off of street right-of-way that are not maintained.

Kind of Seed	Minimum Live Seed	Rate of Pure Live Seed (Lbs. per Acre)
Alta Fescue or Kentucky 31 Fescue (Festuca Elatior Var. Arundinices)	190	240
Rye Grass (Lolium Perenne or L. Multi-florum)	70	85
Total		140

C. Brome Grass Seed

1. Brome grass seed shall be native to eastern Kansas and grown not more than 150 miles north or 250 miles south of the general area in which seed is to be planted. The Contractor shall provide certification of the type of seed and the location where the seed was grown prior to beginning work.
2. Brome grass seed shall be sowed at a rate of 20 lbs. pure live seed per acre. The seed mixture shall also include 100% Annual Rye grass to

provide a temporary grass stand. The rye grass shall be spread at a rate of 90 lbs. pure live seed per acre.

D. Buffalo Grass Seed

1. Buffalo grass seed shall be Sharps Improved, KN03 Applied, or approved equal.
2. Buffalo grass seed shall be sowed at a rate of 44 lbs. pure live seed per acre. The seed mixture shall also include 100% Annual Rye grass to provide a temporary grass stand. The rye grass shall be spread at a rate of 90 lbs. pure live seed per acre.

2.04. SOD

- A. The sod shall be densely rooted nursery grown Kentucky Blue Grass, Turf-Type Tall Fescue, Bermuda Grass, Zoysia Grass or other grasses to match existing lawns unless otherwise indicated on the Drawings. The sod shall be less than two years old, contain a growth of not more than 10 percent of other grass and clovers and shall be free from all prohibited and noxious weeds.
- B. Sod shall be machine cut at a uniform soil thickness of 5/8 inch, plus or minus 1/4 inch, at the time of cutting. Measurement for thickness shall exclude top growth and thatch. Before stripping, sod shall be mowed uniformly at a height of 2 to 3 inches. Sod shall be cut in strips not less than 12 inches wide; each strip containing at least one square yard. Broken pads and torn or uneven ends will not be acceptable. Standard size sections of sod shall be strong enough to support their own weight and should retain their size and shape when suspended vertically from a firm grasp on the upper 10 percent of the section. Sod shall not be harvested or transplanted when moisture content (excessively dry or wet) will adversely affect its survival.
- C. Sod shall be relatively free of thatch, up to 1/2 inch allowable (uncompressed). Sod shall be reasonably free of diseases, nematodes, and soil-borne insects. State nursery and/or plant materials' laws require that all sod entering inter-state commerce be inspected and approved for sale. The same applies to sod being shipped intra-state. The inspections and approval must be made by the State Agricultural Department, Office of the State Entomologist.
- D. Sod shall be free of objectionable grassy and broad leaf weeds. Sod shall be considered free of weeds if less than 5 of the following plants are found per 200 square feet of area: quackgrass, Johnson grass, poison ivy, nutsedge, nimblewill, Canada thistle, bindweed, wild garlic, ground ivy, perennial sorrel, brome grass, and bentgrass.

2.05. FERTILIZER

Starter fertilizer for seeding and sodding shall be an approved commercial brand composed of a "Slow Release Nitrogen" fertilizer in the 1-1-1 range, such as 13-13-13, uniform in composition free flowing and suitable for application with approved equipment, delivered to the site in convenient containers, each fully labeled, conforming to the applicable State fertilizer laws, bearing the name, trademark, or trade name, and a warranty of the producer.

2.06. MULCH

- A. Vegetative Type: The vegetative type shall be cereal straw from stalks of oats, rye, wheat or barley and shall be free of prohibited and noxious weed seeds.
- B. Wood Cellulose Fiber Mulch: Wood cellulose fiber shall contain no germination or growth inhibiting ingredients, and shall be dyed an appropriate color to aid in visual metering in its application. It shall be easily and evenly dispersed and suspended when agitated in water, and when sprayed uniformly on the soil surface, shall form a blotterlike cover, which readily absorbs the water and allows infiltration to the underlying soil. The mulch material shall be supplied in packages of not more than 100 pounds gross weight, and shall be marked by the manufacturer to show the air dry weight content. (Air dry weight shall contain no more than 10 per cent moisture).
- C. Erosion Control Mats: Erosion control mats shall be a woven cellulose fabric. The mats shall not require removal after a full stand of grass is achieved.

2.07. PAVEMENT

Except as otherwise specified or indicated, backfill and pavement materials, compositions and mix designs shall comply with the applicable provisions of the respective municipal codes of the city and the county having jurisdiction and the "Standard Specifications for State Road and Bridge Construction" of the Kansas Department of Transportation.

2.08. FENCE

All fencing damaged in removal, by construction or otherwise unsuitable for reinstallation shall be replaced with like materials of equal or better quality than the material used in the original installation.

2.09. TREES, SHRUBS, AND BUSHES

Any tree, shrub, or bush as shown on the Drawings or in the Modifications to Detailed Specifications as "replaced" shall be of the same species as the removed tree, shrub, or bush. Any tree, shrub, or bush species that is prohibited by local restrictions shall be substituted with a related species. Replacement planting shall conform to the guidelines ANSI-Z60.1-2004 "American Standard for Nursery Stock" specified by the American Nursery and Landscape Association.

PART 3 EXECUTION

3.01. TIME AND CONDITIONS

- A. Clean-up, finish grading, and removal of excess excavated materials must follow the trenching and pipe laying operations by a maximum of 14 calendar days. This applies to each segment of pipe (i.e., manhole to manhole or yard by yard for developed areas). If the clean-up, finish grading, and removal of excess excavated materials does not follow the trenching and pipe laying operations satisfactorily, the Owner may direct Contractor to suspend all trenching and pipe laying operations until the clean-up, finish grading, and removal of excess excavated materials is completed. Erosion control measures shall be enacted to

prevent soil erosion by runoff or wind carry in accordance with jurisdictional requirements and regulations on erosion control and the Contractor's Stormwater Pollution Prevention Plan (SWPPP).

- B. During the seeding and sodding placement seasons, the Contractor shall seed and/or sod all disturbed areas in which the Contractor has finished clean-up, finish grading, and removal of excess excavated materials. The seeding and sodding work shall not be started until the pipe segment has been substantially completed and access to the work area(s) is no longer required by the Contractor. Topsoil shall be spread, and finish grading completed before the seeding and/or sodding work is started. Once started, the seeding and/or sodding work shall continue in an expeditious manner until complete. All seeding work shall be completed as specified in paragraph 3.04 below. Sodding shall be completed as specified in paragraph 3.05 below. If trenching and pipe laying operations are completed outside of the placement seasons, the Contractor shall maintain the area in a finish grade condition until the next placement season begins and provide erosion control measures to prevent soil erosion by runoff or wind carry. If trenching and pipe laying operations are completed outside of the placement seasons, seeding and/or sodding shall be completed within 14 calendar days of the beginning of the placement season.

3.02. CLEAN-UP

The Contractor shall prepare the area for finish grading including but not limited to the following items:

- A. Clean-up shall follow the completed backfilling operations as noted in Paragraph 3.01 of this Section.
- B. Compaction shall be completed to the density specified.
- C. Excess material shall be removed from the site including material which has washed in the stream beds, storm water facilities, streets, etc.
- D. Tools, equipment and construction material shall be removed except for that in designated storage areas along the pipeline route, and then shall be stored in a neat appearing manner.
- E. Restore surface and sub-surface drainage and provide temporary wash checks where necessary.
- F. Remove all rock (1-inch and larger in diameter), tree roots and limbs, clay balls, construction debris, weeds and trash.
- G. Topsoil:
 - 1. Prior to finish grading and tilling, the Contractor shall restore the topsoil on the excavated areas to a depth equal to that which existed prior to excavation. At the Contractor's option, the existing topsoil shall be replaced with 1) existing topsoil placed in a segregated stockpile prior to trench excavation or 2) imported topsoil from a suitable location at no additional cost to the Owner. If less than 6 inches of topsoil exists prior to excavation, the Contractor shall, at no additional cost to the Owner,

provide additional topsoil to achieve a minimum depth of 6 inches following construction.

2. Not topsoil shall be removed from an individual property or tract without JCW prior approval.

3.03. FINISH GRADING

The Contractor shall finish grade the restoration areas to lines and grades shown on the Drawings, or if not shown, to those which existed prior to the area being disturbed. Special attention shall be directed to assure proper surface drainage. The area shall be smoothed by raking or dragging.

3.04. CONSTRUCTION DETAILS FOR SEEDING

All workmanship shall meet the approval of the Engineer. Prior to construction, the Contractor shall notify the Engineer of all areas that are not currently able to support vegetation or grasses.

- A. Seeding Seasons: All seeding work shall be done between the dates of February 1 and April 15 for spring planting or August 15 and October 15 for fall planting.
- B. Application of Fertilizer: Before tilling the soil the fertilizer shall be distributed uniformly at the rate of 3.0 total chemical pounds per 1,000 square feet, and incorporated into the soil to a depth of at least 2 inches by discing or harrowing methods.
- C. Tilling the Seed Bed: The surface shall be tilled to a depth of at least 2 inches by discing or other approved methods until the topsoil is suitable for seeding. The seed bed shall be free from all rock (1-inch and larger in diameter), tree roots and limbs, clay balls, construction debris, weeds and trash. Areas tilled shall be maintained until seeding and mulching is complete to insure a smooth area with no gullies or depressions. Approval of the seed bed shall be obtained from the Engineer before seeding is started.
- D. Seed Application: Sowing shall be accomplished by use of an approved mechanical seeder or drill (hand spreader can be used in small areas), making sure that successive seed stripe overlap to provide uniform coverage. The mixtures shall be applied in a crossing pattern of two passes, each applying half of the seed required. Seed should be drilled to a depth of 1/2 inch.
- E. Compaction: Immediately following the completion of seeding operations, the entire area shall be compacted by means of a roller weighing at least 60 pounds per linear foot of roller, but not more than 90 pounds per linear foot of roller.
- F. Mulching: Mulching shall be done within 24 hours following the seeding operation except in the case of wood cellulose fiber type mulch.
 1. Vegetative Type Mulch: After compacting the surface, mulch shall be uniformly spread at the rate of 1 1/2 tons per acre by means of a mechanical spreader or other approved means. As soon as the mulch is spread it shall be anchored to the soil a minimum depth of 3 inches by use of a heavy disc harrow, set nearly straight, or a similar approved tool.

Discs of the anchoring tool shall be set approximately 9 inches apart. Anchoring shall be accomplished by not more than two passes of the tool.

2. Wood Cellulose Fiber-Type: Wood cellulose fiber mulch shall be added to the hydraulic seeder after the proportionate amounts of seed, fertilizer and water, and other approved materials are added. These ingredients shall be mixed to form a slurry which shall be applied at the rate of 1,000 pounds per acre. The mulch shall make a uniform coverage of the soil surface that will be satisfactory to the Engineer.
3. Erosion Control Mats: Erosion control mats shall be used on areas that are prone to erosion and storm water runoff.

G. Protection and Repair: The seeded area shall be kept free of traffic until accepted. If at any time before acceptance by the Owner, any portion of the seeded surface becomes gullied or otherwise damaged, or the seeding has been damaged or destroyed by the Contractor's operations, the affected portion shall be repaired to re-establish the specified condition prior to the acceptance of the work. The Contractor shall notify the property owner prior to beginning the seeding operation. The Owner shall be notified immediately of any damage to the restored areas by other parties

H. Maintenance and Acceptance:

1. Upon completion of seeding work and prior to final payment, meet with each property owner and furnish a seeding maintenance manual(s). Include complete and detailed instructions on the recommended maintenance procedure to be followed for maintaining seeded areas. Include all pertinent growing and maintenance information and requirements for watering, fertilizing, lime applications, spraying, and weed control. Provide a copy of the maintenance manual to JCW for approval prior to distribution.
2. All seeded areas shall be maintained until acceptance by the JCW. Maintenance shall include repair of erosion damage, reseeding, maintenance of mulch, and watering. The Contractor shall warranty all materials and workmanship of the seeding for one calendar year after acceptance by the JCW as specified in paragraph 1.07 of this Section.

3.05. CONSTRUCTION DETAILS FOR SODDING

A. Sodding Seasons: Bluegrass and Fescue sod may be planted during the periods of March 1 to May 15 and September 1 to November 15. Bluegrass and Fescue sod may be planted during the period November 15 to March 1, when the soil and sod is workable and with the approval of the Engineer. Sod shall be placed within 48 hours of cutting. Sod shall not be placed on frozen ground. If sod is planted between November 15 and March 1, the Contractor shall maintain the sod until 20 days after the beginning of the spring sodding season. Zoysia or Bermuda sod may be planted during the period of May 1 to October 15. The Engineer reserves the right to delay the sodding of all types of sod or to vary the permissible sodding seasons, due to weather, soil conditions, or for other causes.

- B. Minimum Topsoil Depth: A minimum of six inches of topsoil shall be placed over all trenched areas and areas disturbed by construction equipment prior to finish grading.
- C. Application of Fertilizer: Before tilling operations, fertilizer shall be spread uniformly at the rate of 3.0 pounds total chemical pounds per 1,000 square feet.
- D. Tilling the Sod Bed: The sod bed shall have a uniform surface free from washes and depressions. The sod bed shall be free from clods, 1-inch diameter and larger rocks, trash, weeds and other debris. The soil, except where fresh top soil has just been applied and compacted, shall be thoroughly tilled to a depth of 2 inches. Freshly graded areas, which have set long enough to become dry and crusted over shall be tilled as specified above, prior to placing the sod.
- E. Placing Sod: Sod shall be moist when it is placed. A clean, cut edge shall be established at the outer limits of the area to be sodded so that good contact can be made between the new sod and the established turf. Sod strips shall be laid along contour lines, commencing at the lowest point of the area and working upward. The transverse joints of sod strips shall be staggered and the sod carefully placed to produce tight joints. Sod shall be laid so that no voids occur. The sod shall be firmed and watered immediately after it is placed. The "firming" shall be accomplished by application of a roller weighting not less than 60 pounds per linear foot of roller nor more than 90 pounds per linear foot of roller. The completed sodded surface shall be true to finished grade, even and firm over the entire area.
- F. Anchoring Sod: On 2:1 slopes, or steeper, the sod shall be anchored with 1/2 inch square by 8-inch long wooden pegs driven into the ground, using three (3) pegs to the square yard or other approved methods. Pegging shall be done immediately after sod is firmed. The area shall then be cleared of loose sod, excess or broken anchors, excessive soil, or other foreign materials.
- G. Maintenance and Acceptance:
 - 1. Upon completion of seeding work and prior to final payment, meet with each property owner and furnish a seeding maintenance manual(s). Include complete and detailed instructions on the recommended maintenance procedure to be followed for maintaining seeded areas. Include all pertinent growing and maintenance information and requirements for watering, fertilizing, lime applications, spraying, mowing, and weed control. Provide a copy of the maintenance manual to JCW for approval prior to distribution.
 - 2. After each day that sod is placed, the sod shall be watered sufficiently to wet the sod pads and at least 2-inches of the sod bed. Thereafter, in the absence of adequate rainfall, watering shall be performed daily and as often as necessary to keep the sod pads moist at all times. Watering by the Contractor shall continue until the roots of the sod are anchored in placed, and the sod is growing and accepted, but at a minimum of a period of 20 days after laying and as often as required thereafter until all sod is growing and accepted by the Owner. The Owner shall be notified immediately of any damage by others to the restored areas.

3. All sodded areas shall be mowed immediately prior to the Engineer's inspection for acceptance. Mowing is required to facilitate visual assessment and acceptability of the work. Mowing shall not be attempted until the sod is firmly rooted and secure in place. Not more than 1/3 of the grass leaf shall be removed. Any debris that would interfere with mowing shall be collected and removed. The Contractor shall warranty all materials and workmanship of the sod for one calendar year after acceptance by the Owner as specified in paragraph 1.07 of this Section.

3.06. PAVEMENT REPLACEMENT

- A. General: Except as otherwise specified or indicated, equipment, details, and construction methods shall comply with the applicable provisions of the respective municipal codes of the city and the county having jurisdiction and the "Standard Specifications for State Road and Bridge Construction" of the Kansas Department of Transportation.
- B. Pavement Replacement: Pavement replacement, as used herein, shall mean reconstruction of the entire structural section of all pavements removed in excavated areas, including sidewalks, driveways and curbing and all pavement surfaces damaged during construction outside of excavation limits. Prior to pavement replacement, all edges that were previously cut but have been subsequently damaged, shall be re-cut and all adjacent undermined and heaved pavement shall be removed.
- C. Backfill: Backfill under pavement shall be installed in accordance with city, county, or state agency having jurisdiction.
- D. Traffic Control: Replacement of pavement shall proceed in accordance with an approved traffic control plan. The traffic control plan shall be approved by the city, county, or state agency having jurisdiction. All traffic control devices and measures shall be provided by the Contractor at no additional cost to the Owner.
- E. Privately Owned Paved Areas and Driveways
 1. The Contractor shall saw cut paved areas and driveways to remove all damaged edges and all undermined and heaved pavement. Saw cuts shall be made perpendicular to the existing pavement edge. If there is an existing joint within 10 feet of the proposed saw cut, then the pavement shall be replaced to the existing joint. However, in no case shall the distance between saw cuts be less than 15 feet.
 2. The paved area or driveway replacement shall match or exceed the existing pavement but in no case shall have a depth less than the existing. As a minimum, all pavements shall be reinforced with #4 bars at 18" centers in each direction or 6" x 6" - W2.9 x W2.9 welded wire fabric at the mid-depth of the slab. All pavement shall be jointed in a manner that matches the original contraction and expansion joints. All contraction joints shall have a depth of 1/4 of the slab thickness and shall be spaced no greater than 15 feet in separation.

3.07. FENCES

- A. All fencing damaged and/or removed during construction shall be restored to a condition equal to or better than that which existed prior to construction. Height and style shall match the remaining fence or that which was removed. All posts shall be plumb and true to line and grade. Spacing shall be uniform and comparable to that in the existing fence system. All line posts shall be embedded two feet six inches; corner and end posts embedded three feet six inches. Wood posts may be driven or set in pre-bored holes.
- B. It shall be the responsibility of the Contractor to survey and record the location of all existing fence corners with a minimum of three ground ties prior to removal of the fences. Copies of all ties to fence corners shall be given to the Engineer.
- C. The erection of the new fences shall be performed by a certified fence erector. The fence erectors must be approved by the Engineer prior to the start of the fence installation.
- D. All temporary fencing installed by the Contractor during construction shall be removed once work is completed.

3.08. WALLS

Retaining and architectural walls, if disturbed or damaged, shall be restored architecturally and structurally to conditions not less than that which existed prior to construction.

3.09. TREES, SHRUBS, AND BUSHES

Any tree, shrub, or bush as shown on the Drawings or in the Modifications to Detailed Specifications as "replaced" shall be planted outside the permanent sanitary sewer right-of-way.

END OF SECTION 2920

SECTION 2930 - NATIVE SEEDING AND RESTORATION PLANTINGS

PART 1 GENERAL

1.01. WORK INCLUDED IN THIS SECTION

- A. This Section governs the furnishing all labor, equipment, and materials, and in performing all operations in connection with native seeding and restoration plantings and completion thereof, in strict accordance with the specifications and Drawings, and subject to the terms and conditions of the contract.
- B. Complete native seeding and restoration plantings at locations indicated by the contract documents. Contractor shall coordinate native seeding and restoration plantings with the affected property owners.

1.02. SPECIFICATION MODIFICATIONS

It is understood that throughout this section these Specifications may be modified by appropriate items in the Modifications to Detailed Specifications or notes on the Contract Drawings.

1.03. REVISIONS OF STANDARDS

When reference is made to a Standard Specification i.e. ASTM, ANSI, AWWA, MCIB, the Specification referred to shall be understood to mean the latest revision of said specification as amended at the time of the Notice to Bidders, except as noted on the Drawings or in the Modifications to Detailed Specifications.

1.04. SUBMITTALS

The Contractor shall provide certifications or shop drawings on all materials provided under these specifications in accordance with the General Requirements. The Contractor shall submit the following:

- A. General: All information required by the Engineer shall be submitted prior to commencing with the native seeding and restoration operation. Work done prior to the Engineer's review of the submittals will be considered unacceptable and shall be removed at the sole cost of the Contractor.
- B. Seed Labels: All producer native seed tags and component native seed analysis labels shall be submitted to the Engineer for acceptance.
- C. Mulch: A weight certificate or delivery ticket for each load of mulch to be used shall be submitted to the Engineer. The certificate shall be used to verify application rates.
- D. Emulsion Type Mulch and Wood Cellulose Fiber: A full product fact sheet from the manufacturer shall be submitted to the Engineer for acceptance.
- E. Tree / Shrub Producer: Tree / shrub producer's name and address and a certificate of inspection substantiating materials comply with specified requirements shall be submitted. The Engineer reserves the right to inspect tree and shrub plantings at the place of growth for compliance with type and quality.

1.05. PERSONNEL AND EQUIPMENT

- A. All work shall be performed by a native grass or restoration Contractor regularly engaged in restoration work, and having personnel who are experienced and qualified in the work required. The Contractor shall be approved by the Engineer prior to the start of the native seeding and restoration plantings.
- B. The native seeding operation shall be accomplished with equipment suitable for herbicide spraying, preparing the seed bed, sowing the seed, soil inoculation, spreading the vegetative type mulch, spreading the emulsion type mulch, or spreading the wood cellulose fiber mulch. On small areas and areas too steep for the safe operation of conventional seeding equipment, the Contractor may use hydraulic seeders.
- C. Equipment necessary for the proper preparation of the ground surface and for handling and placing all required materials shall be of a size appropriate for the areas to be work, on hand, and in good condition.

1.06. GUARANTEE

The Contractor shall unconditionally guarantee until acceptance by JCW a stand of native grass in seeded areas with no less than three healthy specified native grass plants per square foot. As a minimum requirement, all native seeded areas must be equal to or better than adjacent, undisturbed areas. The Contractor shall unconditionally guarantee for one calendar year after acceptance by the Owner a tree/shrub survival rate of no less than 80% of the total restoration plant quantity.

PART 2 PRODUCTS

2.01. GENERAL

- A. Zones: The following zones will be used for defining appropriate locations for native seed, shrubs, and trees and shall be identified on the Drawings.
 - 1. Zone 1 is defined as streambank areas.
 - 2. Zone 2 is defined as riparian and woodland areas.
 - 3. Zone 3 is defined as wetland areas.
 - 4. Zone 4 is defined as wooded wetland areas.

2.02. NATIVE SEEDING

- A. Native Seeds: Native seeds shall comply with the requirements of the applicable state seed laws. Seeds shall be free of prohibited weed seeds and the completed mix shall not have more than 1 percent total of other weed seeds. Seeds shall be delivered to the site in convenient containers, each fully labeled, bearing the name, trade name, or trade mark, and a warranty of the producer and a certificate of the percentage of the purity and germination of each kind of seed specified. Native seeds shall be from local Midwest origin.

B. Native Seeding Mixtures: The native seeding mixtures and the rate of placing pure live seed shall be as specified below, on the Drawings and/or in the Modifications to Detailed Specifications:

1. Zone 1 - Native Seed Mix for Stream Crossing Restoration:

Scientific Name	Common Name	# Pure Live Seed / Acre
<i>Elymus virginicus</i>	Virginia Wild-Rye	6.5
<i>Spartina pectinata</i>	Prairie Cordgrass	3
<i>Panicum virgatum</i>	Switchgrass	2.3
<i>Agrostis alba</i>	Redtop	0.2
<i>Avena sativa</i>	Common Oats (Temporary Cover)	27
<i>Lolium multiflorum</i>	Annual Ryegrass (Temporary Cover)	11

2. Zone 2 - Native Seed Mix for Riparian / Woodland Restoration:

Scientific Name	Common Name	# Pure Live Seed / Acre
<i>Elymus canadensis</i>	Canada Wild-Rye	13
<i>Bouteloua curtipendula</i>	Side Oats Grama	7
<i>Chasmanthium latifolium</i>	Northern Sea Oats	1.2
<i>Carex blanda</i>	Woodland Sedge	0.6
<i>Rudbeckia laciniata</i>	Cut-leaf Coneflower	0.5
<i>Penstemon digitalis</i>	Smooth Beardtongue	0.1
<i>Eupatorium rugosum</i>	Black Snakeroot	0.1
<i>Monarda fistulosa</i>	Wild Bergamot	0.1
<i>Avena sativa</i>	Common Oats (Temporary Cover)	27
<i>Lolium multiflorum</i>	Annual Ryegrass (Temporary Cover)	11

3. Zone 3 - Native Seed Mix for Herbaceous Wetland Restoration:

Scientific Name	Common Name	# Pure Live Seed / Acre
Leersia oryzoides	Rice Cutgrass	1
Carex frankii	Frank's Sedge	1
Carex vulpinoidea	Fox Sedge	0.3
Eleocharis palustris	Creeping Spikerush	0.3
Scirpus atrovirens	Green Bulrush	0.1
Bidens cernua	Nodding Beggartick	1
Verbena hastata	Blue Vervain	0.2
Avena sativa	Common Oats (Temporary Cover)	27
Lolium multiflorum	Annual Ryegrass (Temporary Cover)	11

4. Zone 4 - Native Seed Mix for Wooded Wetland Restoration: To ensure the seed mix is appropriate for specific site conditions and matches the Compensatory Mitigation Plan which may be required by U.S. Army Corps of Engineers (Corps) as part of the Section 404 / 401 permitting process for projects that impact wooded wetlands, a site specific native seed mix for wooded wetland restoration shall be prepared by the Engineer on a case-by-case basis.

C. Pure Live Seed: The following formula shall be used to determine the amount of commercial seed required to provide each kind of seed for the specified quantities of pure live seeds:

$$\text{Pounds of Seed Required} = \frac{10,000 \times \text{Pure Live Seed (lbs. per acre)}}{\text{Purity (Percent)} \times \text{Germination (Percent)}}$$

D. Fertilizer: Fertilizer for native seeding shall consist of 0-3-1 (Nitrogen, Phosphate, Potassium) mixture, uniform in composition free flowing and suitable for application with approved equipment, delivered to the site in convenient containers, each fully labeled, conforming to the applicable state fertilizer laws, bearing the name, trade mark, or trade name, and a warranty of the producer.

E. Mulch: Mulch shall be either the vegetative type or wood cellulose fiber type.

1. Vegetative Type: The vegetative type shall be the cereal straw from stalks of oats, rye, wheat or barley and shall be free of prohibited and noxious weed seeds.
 2. Wood Cellulose Fiber Mulch: Wood cellulose fiber shall contain no germination or growth inhibiting ingredients, and shall be dyed an appropriate color to aid in visual metering in its application. It shall be easily and evenly dispersed and suspended when agitated in water, and when sprayed uniformly on the soil surface, shall form a blotterlike cover, which readily absorbs the water and allows infiltration to the underlying soil. The mulch material shall be supplied in packages of not more than 100 pounds gross weight, and shall be marked by the manufacturer to show the air dry weight content. (Air dry weight shall contain no more than 10 per cent moisture).
- F. Herbicide: Herbicide shall be provided as an individual or combination of chemicals rated for environmental use in and around water. The herbicide shall be delivered to the jobsite in the original manufacturer's container bearing the EPA-registered label.

2.03. RESTORATION PLANTINGS

- A. Native Trees / Shrubs: All native plant material shall be healthy, vigorous, and free from any signs of insect, disease, mechanical injury, or signs of environmental or other stress. Plant roots shall be firm and moist with light-colored root tips. Native tree and shrub species and plant size shall be those specified below, on the Drawings and/or in the Modifications to Detailed Specifications.

1. Zone 1 – Native Plantings for Stream Crossing Restoration:

Scientific Name	Common Name	Plant Size (gallon)	Type
Acer saccharinum	Silver Maple	5	Tree
Fraxinus pennsylvanica	Green Ash	5	Tree
Platanus occidentalis	American Sycamore	5	Tree
Populus deltoides	Eastern Cottonwood	5	Tree
Quercus palustris	Pin Oak	5	Tree
Quercus shumardii	Shumard Oak	5	Tree
Cornus amomum	Silky Dogwood	5	Shrub

Scientific Name	Common Name	Plant Size (gallon)	Type
Cornus sericea	Red Osier Dogwood	5	Shrub
Cephalanthus occidentalis	Buttonbush	5	Shrub
Sambucus canadensis	Elderberry	5	Shrub

- a. Select no less than 4 species of trees and no less than 2 species of shrubs. Any species substitutions by the Contractor shall be approved by the Engineer. The Contractor shall provide and install plantings per technical specifications at the specified locations on the Drawings.
- b. Trees shall be installed on 10 foot centers and shrubs shall be installed on 5 foot centers.

2. Zone 2 – Native Plantings for Riparian / Woodland Restoration:

Scientific Name	Common Name	Plant Size (gallon)	Type
Celtis occidentalis	Hackberry	5	Tree
Fraxinus americana	White Ash	5	Tree
Ulmus rubra	Slippery Elm	5	Tree
Quercus alba	White Oak	5	Tree
Quercus rubra	Northern Red Oak	5	Tree
Cercis canadensis	Eastern Redbud	5	Tree
Tilia americana	American Basswood	5	Tree
Prunus serotina	Black Cherry	5	Tree
Cornus drummondii	Rough-leaf Dogwood	5	Shrub
Prunus americana	American Plum	5	Shrub
Symphoricarpos orbiculatus	Coral-Berry	5	Shrub
Prunus virginiana	Choke Cherry	5	Shrub

- a. Select no less than 4 species of trees and no less than 2 species of shrubs. Any species substitutions by the Contractor shall be approved by the Engineer. The Contractor shall provide and install plantings per technical specifications at the specified locations on the Drawings.
 - b. Trees shall be installed on 20 foot centers and shrubs shall be installed on 10 foot centers.
 3. Zone 4 - Native Plantings for Wooded Wetland Restoration: To ensure that the planting list is appropriate for specific site conditions and meets the Compensatory Mitigation Plan which may be required by U.S. Army Corps of Engineers (Corps) as part of the Section 404 / 401 permitting process for projects that impact wooded wetlands, a site specific native planting list for wooded wetland restoration shall be prepared by the Engineer on a case-by-case basis.
 - B. Fertilizer: Plant fertilizer in tablet and/or granular form shall be organic 12-8-8 controlled release fertilizer tablets with no less than 20% humus, provided in, delivered to the site in convenient containers, each fully labeled, conforming to applicable state fertilizer laws, bearing the name, trade name, or trademark and warranty of the producer.
 - C. Mycorrhizal Inoculant: Plant mycorrhizal inoculant in tablet and/or granular form shall be provided per the plant producer's recommendations.
 - D. Mulch: Wood chip mulch shall be provided for each restoration planting to help retain moisture and reduce weed growth.
- 2.04. IMPORTED TOPSOIL
Imported topsoil shall be as defined in paragraphs 2.01 and 3.02.G of SECTION 2920 - RESTORATION.
- 2.05. WATER
Water used in this work shall be furnished by the Contractor and will be suitable for irrigation and free from ingredients harmful to plant life. All watering equipment required for the work shall be furnished by the Contractor. Water from adjacent fire hydrants or public water lines shall be metered. Written approval from the property owner shall be obtained prior to the use of suitable water from ponds or creeks.

PART 3 EXECUTION

3.01. TIME AND CONDITIONS

All native seeding work shall be completed as specified in Paragraph 3.05 of this Section. Restoration plantings shall be completed as specified in Paragraph 3.06 of this Section. The work shall not be started until all construction and testing, finish grading, and topsoil placement has been completed and access to the work area(s) is no longer required by the Contractor. Once started, the work shall continue in an expeditious manner until complete. When conditions delay native seeding or restoration plantings, erosion control measures shall be enacted to prevent soil erosion by runoff or wind

carry. Clean-up, restoration work, and native seeding and/or restoration plantings shall follow the trenching and pipe laying operations by a maximum of two (2) weeks during the normal seeding and planting periods specified in Paragraph 3.05.A of this Section. If the clean-up, rough grading, restoration, native seeding and restoration plantings do not follow the trenching and pipe laying operations satisfactorily, JCW may suspend all trenching and pipe laying operations until the clean-up, restoration, native seeding and/or restoration planting is completed. Native seeding and/or restoration planting shall be completed only as the weather and installation periods permit.

3.02. RESTORATION

The Contractor shall restore the project site to conditions equal to or better than those existing prior to entry. The Contractor shall maintain adequate safety signs, barricades and lights until final restoration of work area is completed. Public property shall be restored to the requirements of the public body having jurisdiction. The Contractor shall be responsible for coordinating with each city regarding their requirements. The public agency's requirement shall govern except that materials and workmanship shall not be less than required by the plans and specifications.

3.03. CLEAN-UP

The Contractor shall prepare the area for final grading including but not limited to the following items:

- A. Clean-up shall follow backfilling operations as noted in Paragraph 3.01 of this Section.
- B. Excess material shall be removed from the site including material which has washed in the stream beds, storm water facilities, streets, etc.
- C. Tools, equipment and construction material shall be removed except for items in designated storage areas along the pipeline route.
- D. Restore surface and sub-surface drainage and provide temporary wash checks where necessary.
- E. Remove all rock (1-inch and larger in diameter), tree roots and limbs, clay balls, construction debris, weeds and trash.

3.04. FINISH GRADING

The Contractor shall finish grade the restoration areas to lines and grades shown on the Drawings, or if not shown, to those which existed prior to the area being disturbed. Special attention shall be directed to assure proper surface drainage. The area shall be smoothed by raking or dragging.

3.05. CONSTRUCTION DETAILS FOR NATIVE SEEDING

All workmanship shall meet the approval of the Engineer. Prior to construction the Contractor shall notify the Engineer of all areas that are not currently able to support native grasses.

- A. Timing: All native seeding work shall be completed within the following dates:

Normal	Frost Free (earliest April 1) to July 15
Dormant	November 1 to March 31

- B. Erosion Control Materials: Native seeding shall be coordinated with the installation of rolled erosion control products such as erosion control blankets and turf reinforcement mats. In areas where rolled erosion control products shall be used, mulch will not be required; however, phased topsoil placement shall be necessary. Refer to SECTION 2956 - SLOPE AND STREAM BANK/BED STABILIZATION to coordinate native seeding with installation of rolled erosion control products.
- C. Topsoil:
1. The existing topsoil shall be removed for all areas to be disturbed by construction activities and shall be placed in a segregated stockpile. The topsoil stock pile shall be protected from contamination by tree roots, clay balls, rocks, bedding materials, and other debris. When the topsoil is placed for use, it shall be free from tree roots, clay balls, 1 inch diameter and greater stones, and other materials that hinder grading, planting, and maintenance operations and shall be free from noxious and other objectionable weed seeds and toxic substances.
 2. Prior to finish grading and tilling, the Contractor shall restore the topsoil on the excavated areas to a depth equal to that which existed prior to excavation. At the Contractor's option, the existing topsoil shall be replaced with 1) the existing topsoil placed in a segregated stockpile prior to trench excavation or 2) imported topsoil from a suitable location at no additional cost to the Owner. If less than 6 inches of topsoil exists prior to excavation, the Contractor shall, at no additional cost to the Owner, provide additional topsoil to achieve a minimum depth of 6 inches following construction.
- D. Application of Herbicide: Eliminate all existing herbaceous plant materials within disturbance zone by applying herbicide per manufacturer's instruction. Repeat application as required to attain herbicide effectiveness. Follow manufacturer's instruction regarding the wait period necessary before the soil inoculants, native seeding and plantings can be installed.
- E. Application of Fertilizer: Before disking or harrowing the soil, the fertilizer shall be distributed uniformly at the rate defined in the plan documents. Incorporate into the soil to a depth of at least 2-inches by disking or harrowing methods. Fertilizer rate is equivalent to 50 pounds per 1,000 square feet.
- F. Removal of Debris from Seed Bed:
1. The seed bed shall be free from tree roots, clay balls, 1-inch and larger diameter stones, trash, weeds and other debris.
 2. Areas prepared shall be maintained until seeding and mulching is complete to insure a smooth area with no gullies or depressions.

Approval of the seed bed shall be obtained from the Engineer before seeding is started.

- G. Method of Seed Placement: The Contractor shall utilize a seed drill designed and equipped to handle the fluffy seed of native grass species and ensure accurate placement to a depth that will not inhibit emergence. The implement shall be capable of calibration, and the Contractor shall field demonstrate the accuracy of the field implement in placing the specified quantity of native seed.
- H. Compaction: Immediately following the completion of native seed placement, the entire area shall be compacted by means of a cultipacker implement to provide no less than 90 pounds of weight per lineal foot of implement width.
- I. Mulching: Mulching shall be done within 24 hours following the native seeding operation except in the case of wood cellulose fiber type mulch.
 - 1. Vegetative Type Mulch
 - a. After compaction of the surface, mulch shall be uniformly spread at the rate of two (2) tons per acre by means of a mechanical spreader or other approved means.
 - b. As soon as the mulch is spread it shall be anchored to the soil a minimum depth of 1.5 inches by use of a mulch crimper, set nearly straight, or a similar approved implement. Discs of the anchoring tool shall be set approximately 9-inches apart.
 - c. Anchoring shall be accomplished by not more than two passes of the implement.
- J. Maintenance and Acceptance:
 - 1. All seeded areas shall be kept thoroughly watered by the Contractor as required to achieve three healthy specified native grass plants per square foot.
 - 2. Upon completion of seeding work and prior to final payment, meet with each property owner and furnish a seeding maintenance manual(s). Include complete and detailed instructions on the recommended maintenance procedure to be followed for maintaining seeded areas. Include all pertinent growing and maintenance information and requirements for watering, fertilizing, lime applications, spraying, mowing and weed control. Provide a copy of the maintenance manual to JCW for approval prior to distribution.
 - 3. All seeded areas shall be maintained until acceptance by the JCW. Maintenance shall include repair of erosion damage, reseeding, maintenance of erosion control material, and watering.
- K. Protection and Repair: The native seeded area shall be kept free of traffic until accepted. If at any time before acceptance by the Engineer, any portion of the seeded surface becomes gulled or otherwise damaged, or the seeding has been damaged or destroyed by the Contractor's operations, the affected portion shall

be repaired to re-establish the specified condition prior to the acceptance of the work. The Contractor shall notify the property owner prior to beginning the seeding operation. The Owner shall be notified immediately of any damage to the restored areas by other parties.

3.06. CONSTRUCTION DETAILS FOR RESTORATION TREE / SHRUB PLANTINGS

- A. Timing: All native restoration planting work shall be completed within the following dates:

Spring	Frost Free (earliest April 1) to July 15
Fall	September 15 to November 15

- B. Erosion Control Materials: Native planting may require coordination with the installation rolled erosion control products such as erosion control blankets and turf reinforcement mats. In areas where rolled erosion control products shall be used, phased topsoil placement maybe necessary. Refer to SECTION 2956 - SLOPE AND STREAM BANK/BED STABILIZATION to properly coordinate native planting with the installation of rolled erosion control products.

- C. Transport and Storage: All plant material shall be fully protected from wind and sun desiccation during transport (tarps, protective boxes, caps, etc.). Upon arrival at the planting site and prior to planting, plants shall be temporarily stored in a cool, shaded (dark), and wind-protected areas. Plants shall be protected from heat buildup; sun, air, and wind desiccation; freezing; and animal predation at all times. The roots should be kept cool and moist to prevent desiccation and maintain good plant health until they are installed. All plants shall be handled so as to eliminate potential stress or injury.

- D. Placement: Hand excavate or auger a hole to the dimensions shown in the plan documents. The width of the hole should be at least three (3) times the diameter of the container. When digging in poorly drained clay soil, it is important to avoid 'glazing'. Glazing occurs when the sides and bottom of a hole become smoothed forming a barrier, through which water has difficulty passing. To break up the glaze, use a fork to work the bottom and drag the points along the sides of the completed hole. Remove plant from container and check the roots. If the roots are tightly compressed or 'potbound', use fingers or a blunt instrument (to minimize root tearing) to carefully tease the fine roots away from the tight mass and then spread the roots prior to planting. In the case of extremely woody compacted roots, it may be necessary to use a spade to open up the bottom half of the root system. The root system is then pulled apart or "butterflied" prior to planting. Loosening the root structure in this way is extremely important in the case of container plants. Failure to do so may result in the roots 'girdling' and killing the tree. Place plant into hole in an upright, straight position. Incorporate required quantity of specified fertilizer and mycorrhizal inoculant with existing topsoil backfill. Tamp as necessary to minimize settling. Ensure that plant identification tag remains on specimen. Attach a short piece of visible survey tape to the tree or shrub to facilitate future inspection of the plants.

- E. Mulch: Wood chip mulch shall surround each planting at a 3-4 foot radius to a depth of 4 inches to help retain moisture and reduce weed growth. Keep wood mulch away from tree or shrub stems to prevent stem decay and pest problems.
- F. Protection: In areas with a high probability of animal predation, protective structures such as mesh-type, ventilated, plastic tubes shall be installed on the tree or shrub planting.
- G. Watering: Newly planted trees should be watered at the time of planting. In addition, during the first growing season, they should be watered at least once a week in the absence of rain, more often during the height of the summer. Regular deep soakings are better than frequent light wettings. Moisture should reach a depth of 12 to 18 inches below the soil surface to encourage ideal root growth. Maintain watering as required to achieve required survivability.
- H. Restoration Plantings Acceptance:
 - 1. All planted areas shall be kept thoroughly watered by the Contractor as required to achieve a survivability rate of 80%.
 - 2. Upon completion of planting work and prior to final payment, meet with each property owner and furnish a planting maintenance manual(s). Include complete and detailed instructions on the recommended maintenance procedure to be followed for maintaining plantings. Include all pertinent growing and maintenance information and requirements for watering, fertilizing, spraying, and pruning. Provide a copy of the maintenance manual to JCW for approval prior to distribution.
 - 3. The Contractor shall be fully responsible for the condition of the restoration work for one calendar year after acceptance of all other work by the JCW or until written notification that his obligation to maintain the plantings is terminated and the plantings has been accepted.

END OF SECTION 2930

SECTION 2956 - SLOPE AND STREAM BANK/BED STABILIZATION

PART 1 GENERAL

1.01. WORK INCLUDED IN THIS SECTION

This Section governs the furnishing all equipment, labor and materials for installing the following slope and stream bank/bed stabilization materials to the lines, grades, sizes and thicknesses as indicated herein and shown on the Drawings:

- A. Erosion control products for soil reinforcement and slope protection
- B. Mixtures of graded rock to obtain widely graded, non-uniform blend of sand, gravel, cobble and boulders for steam bank protection, stream restoration and stream profile stabilization revetments

1.02. SPECIFICATION MODIFICATIONS

It is understood that throughout this section these Specifications may be modified by appropriate items in the Modifications to Detailed Specifications or notes on the Contract Drawings.

1.03. REVISIONS OF STANDARDS

When reference is made to a Standard Specification i.e. ASTM, ANSI, APWA, AWWA, KDOT, MCIB, the Specification referred to shall be understood to mean the latest revision of said specification as amended at the time of the Notice to Bidders, except as noted on the Drawings or in the Modifications to Detailed Specifications.

1.04. SUBMITTALS

The Contractor shall provide certifications or shop drawings on all materials provided under these specifications in accordance with the General Requirements. The Contractor shall submit the following:

- A. Graded Rock: Because of the wide gradation of the materials specified and multiple means of obtaining compliance using available materials, the Contractor shall follow the general requirements listed below and one of the following three methods of obtaining compliance with the quality assurance requirements.
 - 1. General Requirements: Common to 3 gradation compliance methods
 - a. Approval of graded rock material from a particular source or quarry shall not be construed as constituting approval of all material delivered from that source.
 - b. Submittals shall be made for any proposed materials substitutions. Any existing riprap or excavated rock present at the site that appears to meet the project specification as determined by the Contractor may be used with written approval from the Engineer.
 - c. Testing reports supplied from the source quarry shall not be accepted for material tests older than 90 days prior to the date of product delivery.

- d. Each submittal must be marked as reviewed by the contractor prior to submitting to the Engineer.
2. Gradation Compliance Method 1: For a quarry-furnished rock gradation that has been previously tested and meets the specifications
 - a. Prior to delivery of graded rock material to the work site, submit quarry certifications that stone materials meet specific gravity, soundness, abrasion and general gradation requirements including uniformity coefficient as noted on the Drawings or, if not on the Drawings, as noted herein. Testing reports including gradation shall be supplied for each class of rock specified.
 3. Gradation Compliance Method 2: For multiple quarry-furnished rock gradations that when mixed together at the quarry prior to delivery are intended to meet the specifications
 - a. Prior to delivery of graded rock materials to the work site, inspection of the quarry maybe arranged by the contractor and shall include the Contractor, Engineer and Quarry Representative.
 - b. The quarry shall supply testing results only for specific gravity, soundness and abrasion for various material proposed for mixing at the source.
 - c. The materials will then be placed in an approved area at the quarry or source and sized, sorted or mixed as necessary to obtain compliance. The Contractor shall supply all labor and equipment necessary to measure, sort and mix the materials.
 - d. A random sample of the mixed materials will then be selected at the quarry and gradation determined by pebble count method. The objective is to obtain a sample as it would be handled for normal delivery to the work site. Summary gradation curves and uniformity coefficient from this procedure shall be submitted to the Engineer for approval prior to delivery of the material to the site.
 4. Gradation Compliance Method 3: For multiple quarry-furnished rock gradations that when mixed together by the Contractor on the project site are intended to meet the specifications or when suitable “on site” materials are present to meet the specifications
 - a. Following receipt and review of quarry testing results for specific gravity, soundness, abrasion and gradation of proposed materials to be delivered and mixed on site, the contractor may provide field tests to verify gradation compliance using on site mixing methods.
 - b. The quarry will identify the various rock source(s), proportions and procedures that should be used to stockpile, mix, and grade the material to the gradation specified prior to delivery to the job site.
 - c. The test shall be done using the pebble count method in lieu of sieve/screen analysis/testing for mixed materials. Summary

gradation curves and uniformity coefficient from this procedure shall be submitted to the Engineer for approval prior to installing the rock on site.

- d. If gradation is to be obtained via construction sequencing of various materials and/or on site mixing techniques to meet the specific requirements for graded rock, the Engineer will determine compliance with the gradation requirements by pebble count and visual inspection of the installed material. For this option installed stone gradation shall have a uniformity coefficient exceeding 4.0.
- B. Erosion Control Products: Submit manufacturer product information prior to commencing with project restoration. Supply manufacturer's recommended staple pattern. Work done prior to Engineer's review of the submittals may be considered unacceptable and shall be removed at the sole cost of the Contractor.

1.05. REFERENCED DOCUMENTS

- A. This specification references standards from Standard Specification which are made a part hereof by such reference and shall be the latest edition and revision thereof. In case of conflicting requirements between this specification and these referenced documents, this specification will govern.
- B. Kansas Department of Transportation Standard Specifications for State Road and Bridge Construction
 - 1. Subsection 1114 Stone for Riprap, Wash Checks, Ditch lining and other Miscellaneous Uses
 - 2. Subsection 1115 Methods of Testing for Section 1000 Aggregates
 - 3. KTMR-21 Soundness and Modified Soundness of Aggregates by Freezing and Thawing
 - 4. KTMR-25 Resistance to Degradation of Small-Size Coarse Aggregate by Abrasion and Impact in the Los Angeles Machine
- C. American Society of Testing and Materials (ASTM)
 - 1. ASTM C88 Standard Test Method for Soundness of Aggregates by Use of Sodium Sulfate or Magnesium Sulfate
 - 2. ASTM C128 Specific Gravity of Coarse Aggregate (KT-6)
 - 3. ASTM C131 Resistance to Degradation of Small-Size Coarse Aggregate by Abrasion and Impact in the Los Angeles Machine (KTMR-25)
 - 4. ASTM C136 Sieve Analysis of Fine and Coarse Aggregate (KT-2)
 - 5. ASTM C535 Test Method for Resistance to Degradation of Large-Size Coarse Aggregate by Abrasion and Impact in the Los Angeles Machine (KTMR-21)

6. ASTM D698 Standard Test Method for Laboratory Compaction Characteristics of Soil Using Standard Effort (KT-12)
7. ASTM D6938 Standard Test Method for In-Place Density and Water Content of Soil and Soil-Aggregate by Nuclear Methods (Shallow Depth)

PART 2 PRODUCTS

2.01. GRADED ROCK

A. General

1. The Contractor shall combine multiple gradations of rock into widely graded mixtures of sand, gravel, cobbles, and boulders as shown on the Drawings.
2. All graded rock shall be founded on a filter layer of Class C Graded Rock. Geotextile fabric shall not be used as a filter.
3. All graded rock materials shall be free of organic matter, debris, and other objectionable materials and coatings. Asphalt, concrete or other material not classified as rock will not be allowed.
4. All rock shall be angular, no round stones, thin slab-type stones, or flaking rock shall be used.

B. Class A Graded Rock:

1. Class A Graded Rock shall be mixed together with Class B Graded Rock and Class C Graded Rock to form a mixture with minimum practicable percentage of voids that acts as a foundation of boulders for all revetments.
2. Class A Graded Rock shall:
 - a. Consist of dense, sound, angular rock fragments, cobble and boulders resistant to abrasion and free from cracks, seams, and other defects that unduly increase their destruction by water and frost. Shale and stone with shale seams are not acceptable.
 - b. Have most stones nearly cubicle, with less than 10% having neither breadth nor thickness of a single stone less than 1/3 its length. No stone shall have an elongation greater than 4:1.
 - c. Have a specific gravity (saturated surface dry basis) not less than 2.4, and absorption not exceeding 5% when tested in accordance with ASTM C128.
 - d. Not exceed 15% loss in weight when subjected to five cycles of a soundness test, in accordance with ASTM C88 using magnesium sulfate.

- e. Not exceed 40% abrasion after 500 revolutions when tested in accordance with ASTM C535.
- f. Be reasonably well graded within and conform to requirements as indicated on the Drawings. If gradation is not provided on the Drawings, the following material should be supplied for Class A Graded Rock:

% Passing (By Weight)	Size	Weight	Rock Spec
100-85	30"	½ T	D100
85-50	24"	¼ T	D60
60-40	15"	180#	D50
30-15	8"	40#	D15
25-5	6"	10#	D10

C. Class B Graded Rock:

- 1. Class B Graded Rock shall be mixed together with Class C Graded Rock to form a mixture with minimum practicable percentage of voids that mimics stream bed pavement materials with a wide variation of particle sizes.
- 2. Class B Graded Rock shall:
 - a. Consist of clean, sound, durable, angular particles of crushed stone or crushed gravel or natural cobble with gravel.
 - b. Not exceed 15% loss in weight of when subjected to five cycles of the soundness test, in accordance with ASTM C88 using magnesium sulfate.
 - c. Not exceed 50% abrasion after 1,000 revolutions when tested in accordance with ASTM C131.
 - d. Be tested as indicated in ASTM C136 to ensure that it meets the gradation indicated on the Drawings. Pebble count analysis shall be an acceptable alternative to sieve analysis. If gradation is not provided on the Drawings, the following material should be supplied for Class B Graded Rock (similar to APWA 2605.2 B.1 or KDOT Stone For Aggregate Ditch Lining D50=8"):

% Passing (By Weight)	Size	Rock Spec
100-85	15"	D100
85-50	12"	D60
60-40	8"	D50
30-15	6"	D15
25-5	4"	D10

D. Class C Graded Rock (Fluvial Backfill And Bedding):

1. Class C Graded Rock shall:
 - a. Consist of clean, sound, durable, angular particles of crushed stone or crushed gravel and/or sand. The material is intended to mimic in active situ streambed materials and may included up to 20% sand size particles.
 - b. Not exceed 15% loss in weight of when subjected to five cycles of the soundness test, in accordance with ASTM C88 using magnesium sulfate.
 - c. Be tested as indicated in ASTM C136 to ensure that it meets the gradation indicated on the Drawings. If gradation is not provided on the Drawings, the following material should be supplied for Class C Graded Rock (similar to KDOT Type 1 Stone for Filter Course):

% Passing (By Weight)	Size/Sieve	Rock Spec
100-85	4"	D100
95-70	2"	D85
85-50	1 1/2"	D60
65-35	1"	D50
35-15	3/8"	D15
30-5	#4	D10

- d. Some or all of Class C Graded Rock may be substituted with onsite alluvial materials with written approval from the Engineer. The contractor shall separate the desired substitute material for inspection by the Engineer a minimum of one week prior to use. The Engineer will accept or reject the substitute material in writing within two business days of material inspection.

2.02. SOIL REINFORCEMENT AND SLOPE PROTECTION PRODUCTS:

- A. The Contractor shall provide the following soil reinforcement and slope protection products as shown on the Drawings:

Material	Component	Requirement
Type I ECB Erosion Control Blanket	Organic Material:	Straw
	Mass/yd2:	0.40 lbs (minimum)
	Reinforcement Configuration:	Single Net
	Suggested Manufacturer:	North American Green S75

Material	Component	Requirement
Type II ECB Erosion Control Blanket	Organic Material:	70% Straw/ 30% Coconut Blend
	Mass/yd2:	0.50 lbs (minimum)
	Reinforcement Configuration:	Double Net (non plastic)
	Suggested Manufacturer:	North American Green SC150BN
TRM Turf Reinforced Matrix	Synthetic Material:	Nylon or equivalent monofilament
	Mass/yd2:	0.5 lb (minimum)
	Suggested Manufacturer:	Maccaferri - 7010 Series
Wire TRM Wire Reinforced Matrix	Suggested Manufacturer:	Maccaferri - MacMat R6P

- B. The use of two-component TRM or Wire TRM systems will not be acceptable.
- C. Provide staples and pins per the manufacturer's recommendation.
- D. Provide rebar J-hooks or approved heavy duty geotextile pin/fastener required for use with the Wire TRM. The length and size of J-hook rebar shall be dependent on location of material installation as follows:

Location	Bar Size	J-Hook Length
Top of Slope Anchor Trenches	#4 (0.50")	48 inches
Slopes/Stream bank	#3 (0.375")	24 inches
Toe of Slope Termination	#5 (0.625")	36 inches

PART 3 EXECUTION

3.01. GENERAL

- A. No material shall be placed until the subgrade has been cleared, stripped and dewatered or otherwise prepared in accordance with the provisions of the specifications and as specified on the Drawings.
- B. No material shall be placed on or against frozen material. Frozen material shall not be used in any installation.
- C. No material shall be placed until the subgrade has been checked and approved by the Engineer.
- D. Where the materials listed in this specification are to be placed and compacted against structures, the structures shall be supported laterally as necessary to prevent damaging or displacing the structure. Any structure so damaged as a

result of the contractor's operation shall be completely and promptly repaired or replaced.

- E. The design techniques specified for stream restoration are particularly sensitive to abrupt transitions, locations of existing trees, and final cross sections and profile. The Contractor shall anticipate that the final stream cross sections may be modified by the Engineer via field order.
- F. At locations where the installation calls to meet/match another surface (e.g., at concrete structure, adjacent grades), the riprap surface shall match the other surface in such a manner so that it prevents ponding of water at the other surface or otherwise restricts the flow of water across the other surface.
- G. Materials shall be mixed in a manner that will result in well-blended material. The Contractor shall make such adjustments in mixing procedures or in equipment as may be required or directed to obtain the true grades, to minimize segregation and degradation and to ensure a satisfactory installation of the material, meeting the requirements of the specifications and Drawings.
- H. Final placement of materials shall be in the locations indicated on the Drawings and/or specified by the Engineer. If the Contractor's width of disturbance exceeds the width of stabilization shown on the Drawings, the Contractor shall widen the stabilization to the actual width of disturbance at no additional cost to the Owner.
- I. The placed materials shall be maintained in a satisfactory condition until accepted. Damage to placed material prior to the acceptance of work or placement of the subsequent material due to settlement, washing, or damage by freezing or other weather conditions shall be repaired and grades re-established to the required elevations, slopes and compaction requirements specified.

3.02. PLACEMENT OF GRADED ROCK MATERIALS

- A. The Contractor shall visually inspect all imported material prior to allowing it to be stockpiled at the work site. Imported material that is found to be unacceptable by visual inspection will be refused by the Engineer.
- B. All rock materials not meeting the requirements of these specifications as determined by tests and/or inspection will be rejected, and any rejected material at the site shall be disposed of in an approved manner.
- C. Prior to commencing work for installing graded rock, install water control measures as required to perform work in dry conditions. Water control measures shall include, but are not limited to, diversions, sumps with pumps, or other means necessary to maintain the level of groundwater below subgrade elevation and to divert surface water away from the work area.
- D. Grade stream banks to the grade shown on the Drawings. In no case shall the restored slope exceed 1.7H:1V, except areas in transition to existing banks which shall be no greater than 1H:1V.

- E. The Contractor shall test the subgrade compaction. If the subgrade is at less than 90% of maximum density (ASTM D698) or less than 70% per ASTM D4253, then subgrade shall be scarified and compacted to meet this required compaction density. The costs for the all density tests necessary to confirm the required density will be borne by the Contractor.
- F. After verification of required compaction density of the subgrade, scarify the top 1 to 2 inches to ensure that the Class C Graded Rock will bond to the subgrade material.
- G. All Class A and Class B Graded Rock shall be installed on a bedding of Class C Graded Rock. Install Class C Graded Rock bedding to the limits and depth requirements on the Drawings. If no depth is indicated on the Drawings, Class C Graded Rock shall be uniformly spread using approved devices and machinery to a minimum 10-inch thickness and lightly compacted using compaction equipment or by slicing with a shovel or light tamping.
- H. After installing Class C Graded Rock bedding, install Class A and/or B Graded Rock to the limits, depth, grades and elevations specified or indicated on the Drawings.
 - 1. Class A Graded Rock shall be placed along the toe of the stream channel, for the foundation of in-stream weirs, or for the boundaries of energy dissipation pools. Unless noted on the Drawings, in-stream weir foundations and rock toe protection shall consist of Class A Graded Rock and be a minimum of 6' wide at the base and shall extend to the bedrock if the bedrock is within 10' of the top of bank ground elevation or 4' below the stream bottom. Position and elevation of the inflection points for in-stream weirs are as shown on the Drawings. The Contractor shall anticipate that manual placement of some individual stones will be required to achieve the desired section.
 - 2. The Contractor shall anticipate that some boulders in Class A Graded Rock will need to be individually placed in a manner to avoid displacing underlying materials or placing undue impact force on the underlying materials. Each stone shall be placed to its final position by the use of a multi-prong grapple device or suitable equipment for handling material and, if necessary, the stone shall be picked up and repositioned. Dragline buckets and skips shall not be used for placement of boulders. Moving stone by drifting or manipulation down a slope will not be permitted. Boulders shall not be dropped from a height of greater than 1 foot. It should be anticipated that re-handling of individual stones after initial placement will be required to achieve required slopes, grades, elevations and position.
 - 3. All graded rock shall be placed in a manner which will provide a reasonably well graded mass of stone with the minimum practicable percentage of voids. The larger stones shall be well distributed and the entire mass of stone shall conform to the specified gradation. All material shall be placed and distributed so that there will be no objectionable accumulations of either the larger or smaller sizes of stone. Dumping alone will not be sufficient to ensure proper interlocked placement.

- I. Mixing and interlocking: It is essential that the material between the larger stones not be loose or easily displaced by flow or by vandalism. The material shall be placed in a manner that will ensure that larger rock fragments are uniformly distributed and smaller rock fragments serve to fill the spaces between the larger rock fragments in a manner that will result in a well-keyed, densely placed revetment. The stone may be consolidated by the bucket of a backhoe or other means that will cause interlocking of the material.
 - 1. As described above, generally Class C Graded Rock should be placed in the bottom layer as a filter between on site soils and the revetment. Class A Graded Rock should then be placed as foundation rocks. Final covering and shaping of the weir and toe protection revetments should be finished with class B graded rock. Voids will be filled completely with Class C Graded Rock such that it is securely locked between the larger Class A or B stones.
 - 2. Due to segregation of the widely graded stone materials specified, the Contractor shall assume that on-site mixing of the rock materials and/or multiple laying techniques will be necessary to achieve the correct size distribution needed to achieve a non-uniform mixture of the soil, sand, gravel, cobble, and boulder materials.

- J. Finishing the revetment: The Contractor shall produce a fairly compact stream revetment in which all sizes of material are placed in their proper proportions. The finished material shall produce a reasonably solid mass within the limits shown on the Drawings. The surface shall be uniform and free from bulges, humps, or cavities with no projections above or depressions under the finished design grade more than 10% of the rock layer thickness.
 - 1. Hand placing of smaller rock will be required only to the extent necessary to secure the results specified herein which may be necessary for the finished surface to conform to the specified lines, grades, and cross sections.
 - 2. The finished rock revetments shall be free of pockets of small rocks and clusters of larger rocks and produce a reasonably well-graded mass of rocks with the minimum practicable percentage of voids.
 - 3. The finished grade of the toe revetments and in-stream weirs shall be within 0.3 foot (plus/minus) of the grade(s) indicated on the Drawings.
 - 4. Should the surface for any reason become rough, corrugated, or uneven in texture prior to the completion of the project, such unsatisfactory portion shall be reworked or replaced as directed by the Contractor as necessary to achieve the requirements of the specification.

3.03. PLACEMENT OF SOIL REINFORCEMENT PRODUCTS

- A. The Contractor shall assume a 20% scrap factor (overlap and burial loss) for soil reinforcement products. Material shall be trenched at the top of each bank and be installed to match the final graded contour of the soil surface. The Contractor

shall include the cost of all scrap and trench-secured quantities in their bid. Such quantities are considered incidental and non-payable for the project.

- B. Prior to commencing work for installing soil reinforcement products, the subgrade shall be prepared. The prepared surface should be free from tree roots, clay balls, 1-inch and larger diameter stones, trash, weeds and other debris.
- C. The installed product shall maintain contact with the underlying soils to prevent undermining and tenting from germinating plants. No ruts, rills or other surface deformities shall exist at the time of installation. Contact between the subgrade and material shall exceed 90% of the surface area of the installed material.
- D. The Contractor shall take measures as necessary to temporarily prevent concentrated runoff from draining onto the restored slopes to prevent rill erosion.
- E. The Contractor shall provide survey stakes as necessary to ensure the slope is restored to the lines and grades shown on the Drawings.
- F. The Contractor shall test the subgrade compaction. If the subgrade is at less than 90% of maximum density (ASTM D698) or less than 70% per ASTM D4253, then subgrade shall be scarified and compacted to meet this required compaction density. The costs for the density tests will be borne by the contractor. If the density tests fail, the contractor shall be responsible for the cost of subsequent retesting which must be performed until the failed test area has been retested to meet the specified requirements.
- G. Installation of Type 1 and Type II Erosion Control Blanket (ECB).
 - 1. Install topsoil, fertilizer and prepare seed bed per SECTION 2930 - NATIVE SEEDING AND RESTORATION PLANTINGS. Plant the native seed prior to placing ECB.
 - 2. Install ECB in locations shown on the Drawings ensuring to trench and staple ECB's at the top, toe and edges of slope. Compact anchor trench and place geotextile pins as required to secure blanket.
 - 3. Finished product should be planar with the slope surface and free from depressions or bumps greater than 2".
- H. Installation of Turf Reinforced Matrix (TRM).
 - 1. Install topsoil and fertilizer per SECTION 2930 - NATIVE SEEDING AND RESTORATION PLANTINGS. Do not seed prior to placing the TRM.
 - 2. Install TRM in locations shown on the Drawings ensuring to trench and staple at the top, toe and edges of the slope. Place onto compacted topsoil.
 - 3. Fill the installed TRM with a minimum of 1" of topsoil. Sow native seed by broadcasting seed onto soil-filled TRM.
 - 4. Cover TRM with Type 1 ECB.

5. Compact anchor trenches and place geotextile pins to secure both ECB and TRM.
 6. Finished product shall be planar with the slope surface and free from depressions or bumps greater than 2".
- I. Installation of Wire Reinforced Matrix (WTRM).
1. Install topsoil and fertilizer per SECTION 2930 - NATIVE SEEDING AND RESTORATION PLANTINGS. Do not seed prior to placing the Wire TRM.
 2. Compact the subgrade prior to installing Wire TRM. Place Wire TRM onto compacted topsoil and install in locations shown on the Drawings ensuring to trench and staple at the top, toe and edges of the slope with heavy duty geotextile fastener.
 3. Wire TRM may need to be cut to bend the material for the anchor trench. 4 heavy duty geotextile pins (J-Hooks) should be used per square yard of material or 1 every 3 feet in the trench.
 4. Fill the installed Wire TRM with a minimum of 2" of topsoil. Sow native seed by broadcasting seed onto soil-filled Wire TRM.
 5. Cover Wire TRM with Type 1 ECB.
 6. Compact anchor trenches and place geotextile pins to secure both ECB and Wire TRM.
 7. Provide additional pinning and stapling as necessary to maintain contact with the subgrade. Finished product shall be planar with the slope surface and free from depressions or bumps greater than 2".
- J. Protection and Repair: If at any time before acceptance by the Engineer, any portion of the restored surface becomes gulled or otherwise damaged, or the seeding has been damaged or destroyed by the Contractor's operations, the affected portion shall be repaired to re-establish the specified condition prior to the acceptance of the work.

3.04. INSPECTION

- A. Prior to installation inspection
1. Inspect for unsuitable and objectionable materials that are visually recognizable in stock piles.
 2. Inspect size and gradation to ensure that material visually appears to be suitable material.
 3. Visually inspect subgrade prior to placement of rock.
 4. Check for soil reinforcement products and pins on site that meet the specifications.

B. During installation inspection

1. Inspect for Class C Graded Rock as bedding material.
2. Ensure rock placement to the minimum depths indicated on the Drawings. Ensure rock toes are built at or below the depths indicated on the Drawings.
3. Check that top of rock revetments are built to the line and grades shown on the Drawings. Placing rock on top of the existing ground or streambed without excavating will generally not meet the lines and grades shown. Placing rock above the elevations or heights above streambed shown on the Drawings will not be accepted.
4. Check that subgrade is relatively smooth and compacted with topsoil prior to placement of soil reinforcement products.
5. Check that soil reinforcement products are properly anchored and pinned per the Drawings and manufacturer's recommendations.
6. Check that installation is proceeding to the applicable requirements for placement, compaction, smoothness and grade tolerance specified herein.

C. Post installation inspection

1. Check that the revetment neither causes an expanded flow width than adjacent stream or backwater in the channel.
2. Overtly large stones on the on the surface of the final revetment is will not be accepted. Class A rock shall not be identifiable on the surface of a finished revetment.
3. Ensure anchor trenches for soil reinforcement products are compacted and seeded.

END OF SECTION 2956

SECTION 3000 - CAST-IN-PLACE CONCRETE

PART 1 GENERAL

1.01. WORK INCLUDED IN THIS SECTION

This Section governs the construction of all Portland cement cast-in-place concrete required by the Drawings or specified herein and includes, but is not necessarily limited to: all cement, aggregates, admixtures, reinforcing, tie bars, dowels, inserts, supports, spacers, form materials, form coatings, curing materials; and all mix design, mixing, transporting, forming, placing and bending of reinforcement, preparation for concrete placement, placement of concrete, consolidation, finishing, curing, and other items or operations required to provide sound and finished concrete work.

All construction of cast-in-place concrete for the repair of curbs, sidewalks, driveways, etc. shall conform to the governing authority's requirements including requirements for sampling and testing.

1.02. SPECIFICATION MODIFICATIONS

It is understood that throughout this section these Specifications may be modified by appropriate items in the Modifications to Detailed Specifications or notes on the Contract Drawings.

1.03. REVISIONS OF STANDARDS

When reference is made to a Standard Specification i.e. ASTM, ANSI, AWWA, MCIB, the Specification referred to shall be understood to mean the latest revision of said specification as amended at the time of the Notice to Bidders, except as noted on the Drawings or in the Modifications to Detailed Specifications.

1.04. SUBMITTALS

- A. The Contractor shall provide certifications or shop drawings on all materials provided under these specifications in accordance with the General Requirements.
- B. Unless otherwise approved by the Engineer, shop drawings shall be submitted for the following items of material and equipment:
 - 1. Reinforcing Steel (placing drawings and mill tests).
 - 2. Joint materials and sealants.
 - 3. Metal Accessory items.
 - 4. Concrete Aggregates (See Paragraph 1.06)
 - 5. Concrete Mix Design (See Paragraph 2.01)
 - 6. Concrete Cylinder Tests (See Paragraph 1.06).

- C. The Contractor shall furnish a manufacturer's certification, in triplicate, showing typical test results representative of the expansion joint materials and certifying that the materials supplied conform to the requirements specified.
- D. The Engineer's approval of such drawings shall be obtained prior to fabrication and concrete placement. The Contractor shall be solely responsible for the adequacy and safety of formwork design and reinforcing steel placement lists.

1.05. APPLICABLE STANDARDS

The latest editions, supplements and revisions of the following shall apply where applicable to all concrete work and where referenced herein.

- A. American Society for Testing Materials (ASTM)
 - 1. A185 Standard Specification for Steel Welded Wire Fabric, Plain, for Concrete Reinforcement
 - 2. A615 Standard Specification for Deformed and Plain Billet-Steel Bars for Concrete Reinforcement
 - 3. C31 Standard Practice of Making and Curing Concrete Test Specimens in the Field
 - 4. C33 Standard Specification for Concrete Aggregates
 - 5. C39 Standard Test Method for Compressive Strength of Cylindrical Concrete Specimens
 - 6. C40 Standard Test Method for Organic Impurities in Fine Aggregates for Concrete
 - 7. C88 Standard Test Method for Soundness of Aggregates by Use of Sodium Sulfate or Magnesium Sulfate
 - 8. C117 Standard Test Method for Material Finer Than 75- μ m (No. 200) Sieve in Mineral Aggregates by Washing
 - 9. C123 Standard Test Method for Lightweight Particles in Aggregate
 - 10. C136 Standard Test Method for Sieve Analysis of Fine and Coarse Aggregates
 - 11. C142 Standard Test Method for Clay Lumps and Friable Particles in Aggregates
 - 12. C143 Standard Test Method for Slump of Hydraulic Cement Concrete
 - 13. C150 Standard Specification for Portland Cement
 - 14. C172 Standard Practice for Sampling Freshly Mixed Concrete
 - 15. C231 Standard Test Method for Air Content of Freshly Mixed Concrete by the Pressure Method

16. C260 Standard Specification for Air-Entraining Admixtures for Concrete
17. C309 Standard Specification for Liquid Membrane-Forming Compounds for Curing Concrete
18. C494 Standard Specification for Chemical Admixtures for Concrete
19. C618 Standard Specification for Coal Fly Ash and Raw or Calcined Natural Pozzolan for Use in Concrete
20. D75 Standard Practice for Sampling Aggregates

B. American Concrete Institute (ACI)

1. 301 Specifications for Structural Concrete for Buildings
2. 304 Guide for Measuring, Mixing, Transporting, and Placing Concrete
3. 305 Hot Weather Concreting
4. 306 Cold Weather Concreting
5. 318 Building Code Requirements for Reinforcing Concrete
6. 347 Guide to Formwork for Concrete
7. 350 Environmental Engineering Concrete Structures

C. American Welding Society Standard Code for Welding in Building Construction

1.06. CONCRETE SAMPLING AND TESTING

A. Testing Laboratory: A recognized testing laboratory selected by the Contractor but subject to approval by the Engineer and JCW, shall be employed by the Contractor to test all materials, prepare design concrete mixes, and to test all concrete to be incorporated in the project. Both the Engineer and the testing laboratory shall have access to all places where concrete materials are stored, proportioned, mixed, and placed. Testing by the testing laboratory shall be performed in accordance with the following:

1. Coarse and fine aggregate shall be sampled and tested as follows:

Sampling	ASTM D75
Gradation	ASTM C136 & C117
Impurities	ASTM C40 (Sand), C123, C142
Soundness	ASTM C88
2. The determination of slump of concrete shall conform to ASTM C143. Slump tests shall be made by laboratory personnel for each pour and on an average of one test per 25 cubic yards of concrete throughout the project. The interval at which slump tests are performed shall also be governed by municipal regulations when those regulations require more frequent testing.

3. **Test Cylinders:** Concrete test cylinders shall be cast, cured, stored, delivered, and tested in accordance with ASTM C172, C31 and C39. Air content shall be determined in accordance with ASTM C231. When ambient temperature is below 50°F or above 70°F, test reports shall also show temperature of concrete at time of placement. A minimum of 4 job cylinders shall be made for each separate concrete pour, or as directed by the Engineer. Cylinders shall be made on an average of 4 per each 50 cubic yards of concrete. The interval at which concrete cylinders are taken shall also be governed by municipal regulations when those regulations require more frequent testing. The Contractor shall ship the cylinders to the laboratory. One cylinder shall be tested on the 7th day and a second cylinder shall be laboratory cured and tested on the 28th day. The third cylinder shall be laboratory cured and held in reserve to verify any questionable cylinder breaks. The fourth shall be used to verify strength at the time the forms are removed.

4. **Test Reports:** The testing laboratory shall furnish five (5) copies of test reports for concrete test cylinders to be distributed as follows:

1	Copy	---	Owner
1	Copy	---	JCW
1	Copy	---	Contractor
1	Copy	---	Engineer
1	Copy	---	Engineer's Resident Project Representative (RPR)
1	Copy	---	Concrete Supplier

5. Unsatisfactory tests of concrete cylinders or excessive slump shall make the concrete concerned subject to rejection, with consequent removal and replacement by the Contractor at no expense to the Owner. The concrete mix shall be redesigned immediately should concrete cylinder tests prove to be unsatisfactory.

- B. **Compliance:** The Contractor shall be responsible for the compliance of all materials and mixing with the requirements of these Technical Specifications. Laboratory certificates shall be furnished to the Engineer's RPR and shall be prepared by a commercial laboratory or by the material manufacturer's laboratory, certifying that each material has been tested and conforms to the requirements of these Technical Specifications.

- C. **Concrete may be accepted on the basis of occasional conventional field sampling and testing for characteristics such as slump and air, where specified, and occasional test beams or test cylinders, with only intermittent or random plant inspection as deemed necessary for control by the Engineer and JCW. Under this system, arrangements will be made for the producer to state on the delivery ticket accompanying each load of concrete the class of concrete being furnished; the weight of cement, aggregate, and water used in the batch; and the time of batching. Only tested aggregate and cement or supplier-certified cement may be used. Concrete based on the above-mentioned procedures may be accepted for use on the following items:**
 1. Sidewalks (not to exceed 500 square yards per day)

PART 2 PRODUCTS

2.01. CONCRETE MATERIALS

All materials shall conform to the standard specifications of the American Society for Testing Materials (latest revision thereof) applying to that particular material and as specified hereafter.

- A. Class A Concrete: Class A concrete used for aerial crossing piers, wet well walls, manhole walls, bases, inverts, flat slabs, road crossings, and any other application not otherwise defined shall have a 28-day strength of 4000 psi, unless otherwise specified.
- B. Class B Concrete: Class B concrete standard concrete used for encasement and embedment, thrust blocks, pipe anchors, and pipe collars shall have a 28-day strength of 3000 psi, unless otherwise specified.
- C. Flowable Fill: Portland cement and sand grout used for impervious ditch checks shall have a 28-day strength of 500 psi, unless otherwise specified.
- D. The concrete mix design shall meet the following requirements:

Concrete Type	A	B	Flowable Fill
Minimum Compressive Strength (psi)	4000	3000	500
Maximum Aggregate Size (inches)	3/4	3/4	1/4
Minimum Cement (lbs.)	611	517	235
Minimum Sack Mix (per c.y.)	6	5 1/2	2 1/2
Maximum Water / Cement Ratio	0.45	0.59	0.928
Maximum Slump (inches)	4	4	8
Air Entrainment (%)	6 ± 1	6 ± 1	8 ± 1

2.02. PORTLAND CEMENT

- A. Type A Concrete: Portland cement for Type A concrete (exposed to confined sewer gases) shall be either 1) Type III or Type IV per ASTM C150 and shall not contain tricalcium aluminate in excess of 5 percent or 2) Type II per ASTM C150 with the addition of Class F pozzolan. With the exception of the Class F pozzolan, no fly ash shall be allowed.
- B. Type B Concrete and Flowable Fill: Portland cement for Type B concrete and flowable fill shall be Type IA, or IIA, air entraining cement or may be Type I or II normal Portland cement if an approved air entraining agent is added to the mix. The approved air entraining agent shall be added in an amount sufficient to entrain from 5.0% to 7.0% free air. No fly ash shall be allowed.
- C. Normal Portland cement shall conform to ASTM C150 and air entraining concrete shall conform to ASTM C260. Cement may be bagged or bulk if concrete is furnished by a ready mixed concrete plant, but bagged only if job mixed. The cement shall be used from only one mill throughout the entire project.

2.03. FINE AGGREGATE

Fine aggregate shall be clean processed natural sand conforming to ASTM C33. The fineness modulus shall be between 2.50 and 3.00 and shall have the following gradation:

Sieve Size No.	Percentage Passing	Percentage Retained
4	95 - 100	0 - 5
8	80 - 90	10 - 20
16	60 - 75	25 - 40
30	35 - 50	50 - 65
50	15 - 30	70 - 85
100	3 - 7	93 - 97

2.04. COARSE AGGREGATE

Coarse aggregate shall be clean processed crushed stone conforming to ASTM C33. Crushed stone shall have the following gradation:

Sieve Size No.	Percent Passing	Percentage Retained
1-inch	100	0
3/4-inch	90 - 100	0 - 10
1/2-inch	25 - 60	40 - 75
3/8-inch	20 - 55	45 - 80
No. 4	0 - 10	90 - 100
No. 8	0 - 5	95 - 100

Flint shall not exceed 4 percent.

2.05. WATER

Potable water shall be used.

2.06. AIR ENTRAINING AGENT

Air entraining agent shall be C 260. Protex "AES", Grace "Darex AEA" or Sika Chemical "Sika AER 104" or approved equal.

2.07. OTHER ADMIXTURES

Other admixtures shall not be used unless shown on the Drawings or approved by the Engineer.

2.08. REINFORCING STEEL

- A. General: All bars shall be new billet steel, conforming to ASTM A615, Grade 60. Submit certificate of ladle analysis, as required by the Engineer, attesting the proper steel has been used. Where plans call for welded steel, the Contractor shall verify the ladle analysis then do all welding in accordance with AWS standards, using proper rods and procedure for that particular steel. Rebar that must be welded shall have weld reinforcing to provide 125 percent splice per ACI 318. Six (6) pull tests of sample bars of each bar size, spliced for the steel analysis used, shall be made. Pull tests shall be for 100% net cross section, with

all reinforcing removed for the test. Submit results to the Engineer per shop drawing requirements prior to any welding on the project.

- B. Deformed Bars: All bars shall be of the deformed type with bonding capabilities equivalent to at least 125 percent of plain bars conforming to ASTM A996.
- C. Wire Mesh: All wire mesh shall be steel welded wire mesh conforming to ASTM A185. Use 6-inch by 6-inch by 8-gauge wire mesh where size is not indicated on the Drawings.
- D. Certified Mill Test Reports: The Contractor shall furnish certified mill test reports for all bars and shall submit to the Engineer duplicate copies of bar drawings and schedules for preliminary checking and five (5) copies for final approval.
- E. Bent Bars: All bent bars shall be accurately cold bent to conform to the approved drawings. Bending details shall conform to the standards of the Concrete Reinforcing Steel Institute. All bars shall be tagged and bundled. Metal marking tags shall be used.

2.09. METAL ACCESSORIES

Spacers, chairs, ties and other devices necessary for properly assembling, placing, spacing, and supporting all reinforcing in place, shall be provided.

2.10. FORMS

- A. General:
 - 1. The Contractor shall be responsible for the design of all falsework framing and formwork. The falsework and forming shall be designed to support all loads placed upon it without appreciable settlement or deformation.
 - 2. Forms shall be mortar tight and sufficiently rigid to prevent distortion due to the pressure of the concrete and other loads incident to the construction operation including vibration. Forms shall be constructed and maintained so as to prevent the opening of joints due to shrinkage of the lumber. They shall be designed to permit easy removal without injury to the concrete.
 - 3. Form lumber shall be #2 or better with minimum thickness of 3/4-inch and containing no holes or loose knots. Lumber forms shall include form liners of plywood or other approved material in interior or visible surfaces of all structures.
 - 4. Aluminum forms shall not be used unless approved in writing by the Engineer.
- B. Forms for Concrete Flatwork (pavement, steps, sidewalk, drainage flumes, etc.) shall be of suitable material to provide a smooth surface finish (1/4" maximum surface irregularity). Flexible forms shall be used for curves of radius less than 100 feet and back edges of sidewalk or curbing in such curved areas, when completed, shall be even without any abrupt angles at changes in horizontal curvature.

- C. Bullnose: Provide 1-inch (approx.) radius bullnose on corners of exposed beams and columns and elsewhere or as shown on the Drawings. Vinylex or Greenstreak corner formers set in forms or 3/4 inch by 3/4-inch chamfer strips of nonabsorbent material shall be used.
- D. Prohibited: Built-up, battered, bent, twisted, broken or dirty forms shall not be used.
- E. Form Ties: Form bolts, rods, or ties shall be made of steel. They shall be of the type that permits the major part of the tie to remain permanently in the structure. They shall be held in place by devices attached to the walls capable of developing the strength of the ties. The ties shall be removed on all surfaces. The ties shall be removed to a depth of at least ½-inch below the concrete surface. The cavities shall be filled with a non-shrink grout, and the surface left sound, smooth, even, and uniform in color.

2.11. EXPANSION JOINT FILLER MATERIAL

Expansion joint filler material shall be placed as specified or as shown on the Drawings. Joint filler material shall be compatible with joint sealant used and shall be installed as recommended by the sealant manufacturer. Joint filler material shall be an expanded closed-cell polyethylene.

2.12. JOINT SEALANT

All joint sealant shall be a one-part polyurethane based rubber sealant, which complies with ASTM C1193, applied in accordance with the manufacturer's recommendations.

2.13. WATER STOPS

Place continuous 6-inch waterstop in all construction joints of concrete structures. Joints shall be constructed with PVC waterstop equivalent to those manufactured by Vinylex Corporation or Greenstreak. Fabricate field joints in waterstop in accordance with manufacturer's instructions.

2.14. NON-SHRINK GROUT

Non-shrink grout shall develop compressive strength not less than three thousand (3,000) pounds per square inch within twenty-four (24) hours per ASTM C109. Suggested Non-Shrink Grout products are: Grace "Supreme", L&M "Crystex", Master Builders "Masterflow 713 Grout" or "Set Grout", Sauereisen Cements "F 100 Level Fill Grout", UPCO "Upcon Super Flow", or Five Star Products "Five Star Grout". Alternatives will be required to comply with ASTM C827, ASTM C109, and ASTM C191.

PART 3 EXECUTION

3.01. STORAGE OF MATERIALS

Concrete materials and reinforcing steel shall be stored in a manner that prevents deterioration, intrusion of foreign matter, or decreased bond. Any material that has deteriorated or has been damaged shall not be used for concrete.

3.02. PROPORTIONING AND MIXING CONCRETE

- A. General: All concrete shall be classified as required in these Specifications and on the Drawings. The testing laboratory shall submit results of the 7-day and 28-day testing laboratory tests on the concrete design mixes to the Engineer and obtain approval thereof prior to the placement of the concrete on the project. Mix designs shall be as shown below or in the General Notes on the Drawings.
- B. Admixtures: Admixtures other than that listed in PART 2 above may be used in concrete only with prior approval by the Engineer. The admixture shall be shown capable of maintaining essentially the same composition and performance throughout the work. Admixtures containing chloride ions shall not be used. Water reducing admixtures, retarding admixtures, accelerating admixtures, and workability agents, if approved, shall conform to ASTM C494.

3.03. READY MIX CONCRETE

Ready mix concrete shall be used for all concrete work. Two-speed mixer trucks will be required. The concrete must be in place within 90 minutes after water is added to the mix and before concrete begins its initial set. Once concrete begins its initial set, it will be immediately rejected.

3.04. FORMING

- A. General: Forms shall be cleaned and oiled before use and shall conform to the shape, lines, and dimensions of members called for on the Drawings and shall be rigid and watertight. They shall be properly braced or tied together to maintain their position and shape when concrete is tamped or vibrated. Set edge forms and screed strips for concrete flatwork slabs accurately to produce the designed elevations and contours. Construct forms as necessary to support screeds as approved by the Engineer.
- B. Cleanouts shall be provided as required in structure forms to remove sawdust and debris. All contact surfaces shall be sprayed with a form release agent that will not cause injury or strain to exposed concrete surfaces.
- C. Approval: The Engineer's RPR must approve all forms before any concrete is placed. Such approval shall in no way relieve the Contractor of any responsibility for the structural adequacy of form system.

3.05. SUBGRADE PREPARATION

Sub-grade shall be prepared, shaped, and compacted in accordance with requirements set forth by the Engineer.

3.06. PLACING REINFORCING STEEL

- A. General: All reinforcement shall be free from scale, rust, or coatings that will reduce the bond to the concrete. Bars shall be accurately bent and placed as indicated on the Drawings, and securely supported and tied with #16 annealed iron tie wire at all intersections to prevent movement during the placement of concrete.

- B. Connections and Splices: Lap and tie the reinforcing steel together at splices. Splices shall be staggered. All bending, placing and splicing of reinforcing shall be done in accordance with all applicable requirements of the ACI Code and as shown on the Drawings.
- C. Placement: All reinforcing steel shall be placed for minimum concrete covering as follows:
 - 1. Cast against earth 3"
 - 2. All other locations 2"Consult the Drawings for any exception to the above.
- D. Approval by the Engineer's RPR is required at the completion of placing reinforcing steel prior to the placing of any concrete.

3.07. PLACING CONCRETE

- A. General: Concrete shall be deposited with a minimum of rehandling to avoid segregation. No concrete that has partially hardened or been contaminated by foreign material shall be deposited on the Work, nor shall retempered concrete be used. Prior to placing concrete, all water shall be removed from excavations; no concrete shall be placed under water. Sub-grade for slabs less than 12 inches thick shall be dampened. All debris shall be removed from the forms.
- B. Concrete shall be placed continuously in horizontal lifts not exceeding 12 inches in thickness. Placing locations shall be not more than 10 feet apart. Pumping concrete through tremies, hoses, or canvas "elephant trucks" will be required when the concrete has to be dropped farther than 5 feet. Surface water shall be drained off and mixing water shall be reduced as required in the top layers of deep pours. Refer to ACI 304 for placement guidelines.
- C. All concrete shall be thoroughly compacted by spading or vibrating to eliminate voids. At the Contractor's option, concrete curb, where called for on the Drawings, may be placed by use of a curb machine subject to approval by the Engineer.
- D. The working face of the concrete shall be kept plastic and "alive." High frequency vibrators shall be used at all times, supplemented as required with hand tamping, slicing, etc. Avoid vibrator contact against finished face forms or reinforcing steel adjacent to partially set concrete. Avoid over vibration. Tool the top edges of all finally exposed walls and beams with sidewalk edging tool. Concrete shall be cast-in-place in not more than 90 minutes from initial mixing at the plant. Concrete shall be protected against rain or immersion under water for at least 12 hours.

3.08. JOINTS

Control Joints shall be sawed or tooled joints as specified or shown on the Drawings within 12 hours of placing.

- A. Joints in Formed Surfaces: Construction or control joints shall be made only at points shown or noted on the Drawings except where otherwise approved by the Engineer. Refer to Drawings for typical control and construction joint details. Construction joints shall be formed straight and true with finished edges and shall conform to details set forth on the Drawings.

3.09. REMOVING FORMS

Remove forms only after concrete has safe and sufficient strength and only with approval of the Resident Project Representative.

3.10. CONCRETE FINISH

A. Formed Surfaces:

1. Immediately after the removal of forms, the Engineer will examine the exposed concrete. Any concrete not conforming to the lines and grades shown on the Drawings or that shows poor joints, voids, stone pockets, honeycomb, and otherwise defective areas, shall be considered as not conforming with these specifications and shall be replaced by the Contractor at no additional expense to the Owner, except in cases where the Engineer may approve patching the defective parts of the structure. Permission to patch any defective parts of the structure shall not waive the Engineer's right to require the replacement of defective parts if the patching does not, in their opinion, satisfactorily restore the quality and appearance of these defective parts.
2. Specific concrete finishes required will be as follows:
 - a. Outside and inside of all structure surfaces - ties shall be broken and tie holes grouted with honeycombing removed; and
 - b. Structural surfaces exposed to view - rubbed to a smooth finish with a Carborundum brick until form prints are removed and the surface has a smooth, even finish free of voids and honeycomb.

B. Concrete Roadway Pavement:

1. The concrete shall be brought to the proper section by means of a mechanical finishing machine, a vibrating screed, or by an approved type of strike-off board. If a strike-off board is used, it shall be constructed of a material that will not warp, shrink, or sag and shall weigh not less than 10 pounds per linear foot. The strike-off board shall be used as a tamping template, if other equipment is not provided for this purpose, with an up and down motion while being propelled forward. Any of the above devices shall be adjusted to the exact crown of the pavement.
2. After the concrete has been struck off to the proper crown and thickness, a scraper, not less than 6 feet long, shall be drawn across the pavement. The scraper shall be used with its length parallel to the centerline of the pavement and shall be operated in a transverse motion, planing off high spots and filling in depressions. Spacing shall overlap each area by one-half the length of the scraper.

3. The surface shall be checked with a straight edge not less than 10 feet in length mounted on a long handle and any low spots filled in and high spots removed. All disturbed areas shall be refloated. The finished pavement shall not vary more than 3/16 inch from a 10-foot straight edge placed parallel to the centerline.
4. After the water sheen has disappeared, the surface shall be belted with a rubber or fabric belt, approximately 6 inches in width, placed transversely across the pavement and dragged forward with a sawing motion. The final finish shall be made by brooming transversely with an approved burlap drag. All exposed edges of the concrete at joints and back of curb shall be finished with an edging tool of 1/4" radius.

C. Concrete Sidewalk, Paved Ditch and Driveway Pavements:

1. Concrete placed for sidewalk pavement shall be floated with a wood float in such manner that will thoroughly compact it and provide a smooth even surface. Final finishing shall be with a light brushing with a coarse hair brush (not a broom). Steps on grade shall be finished in the same manner.
2. All exposed edges of the concrete at expansion joints and edges of sidewalk shall be finished with an edging tool of 1/4" radius or as otherwise indicated on the Drawings.

D. Concrete Curb and Gutter Sections: All exposed edges of the concrete at joints and back of curb shall be finished with an edging tool of 1/4" radius or as otherwise indicated on the Drawings. When the concrete in curb sections has attained its initial set, a steel trowel shall be used to impart the last shaping finish, and any minor imperfections remedied with a mason's trowel. Final finishing shall be with a moistened brush, by belting, or with a wooden float.

3.11. GROUTING

Non-shrink grout shall be in the plastic state with a trowelable mix and show no expansion after set as tested in accordance with ASTM C827. The placement time shall not be less than forty-five (45) minutes based on initial set per ASTM C191.

3.12. ENVIRONMENTAL CONSIDERATIONS

A. Cold Weather Requirements - Provisions for cold weather concreting shall conform to ACI 306. No concrete shall be placed on iced or frozen sub-grade or when temperature is below 25°F. Concreting shall not be continued when the air temperature is below 45°F unless the following conditions are attained:

1. Mixing water shall be heated to a maximum of 150°F
2. Aggregates shall be heated until free of all ice and frost
3. The concrete temperature after mixing shall be between 50° and 70°F if the air temperature is 20° to 45°F

4. After the concrete is placed, it shall be covered, protected and heated so as to maintain a minimum air temperature of 70°F for the first 24 hours, and 50°F for the next 6 days
 5. Moist conditions shall be maintained during the heating period
 6. All covering, heating equipment, etc., shall be on hand and approved by the Resident Project Representative before any concrete is placed
 7. Admixtures shall be used only with the approval of the Engineer
- B. Hot Weather Requirements: Provisions for hot weather concreting shall conform to ACI 305. No exposed concrete shall be placed in air temperatures above 100°F. Cover, protect, and cool work as required to maintain the temperature of the concrete below 100°F. The concrete temperature, after mixing, shall be not greater than 85°F.

3.13. CURING CONCRETE

Curing shall be maintained continuously for seven (7) days after placing the concrete. Concrete temperature shall be maintained between 50°F and 100°F. Moisture shall be retained in the concrete by the following means:

- A. Walls and Structures - Cover with tarps and leave forms on a minimum of three (3) days, or cover with continuously wet burlap for three (3) days.
- B. Slabs - Immediately after placement, concrete shall be protected from premature drying, extremes in temperatures, rapid temperature change, mechanical injury, and injury from rain and flowing water. Concrete shall be maintained continuously wet for the entire curing period. If water or curing material used stains or discolors concrete surfaces that are to be permanently exposed, the concrete surfaces shall be cleaned. When wooden forms are left in place during curing, they shall be kept wet at all times. If the forms are removed before the end of the curing period, curing shall be carried out as on unformed surfaces, using suitable materials. Horizontal surfaces shall be cured by continuous fogging, or by covering with polyethylene sheets and saturated burlap. If burlap is used, allow to thoroughly dry in place at the end of curing process before removing so as not to allow concrete surface to dry too quickly.

3.14. DEFECTIVE WORK

- A. Concrete that is not in compliance with strength or slump limitations, not formed as detailed, not true to lines and elevations indicated, not properly reinforced as detailed and concrete that has been frozen or has excessive voids, honey-combing or any embedded debris, will not be considered as fully conforming to the intent and provisions of this specification. It shall be deemed defective and shall be removed and replaced when and as directed by the Engineer, at no additional cost to the Owner.
- B. All concrete materials specified shall be from the same manufacturer and source during this Project in order to insure uniformity of color, shade, and texture.

END OF SECTION 3000

SECTION 6650 - PLASTIC LINER FOR PROTECTION OF CONCRETE

PART 1 GENERAL

1.01. WORK INCLUDED IN THIS SECTION

This Section governs the installation of plastic liners for concrete interceptor sewers, precast manholes, and cast-in-place structures. Only plastic liners manufactured with integral locking ribs spaced at approximately 2-1/2 inches on center over entire liner is acceptable. Liners relying on mechanically fastened batten strips, as primary means of anchorage are unacceptable.

1.02. SPECIFICATION MODIFICATIONS

It is understood that throughout this section these Specifications may be modified by appropriate items in the Modifications to Detailed Specifications or notes on the Contract Drawings.

1.03. REVISIONS OF STANDARDS

When reference is made to a Standard Specification i.e. ASTM, ANSI, AWWA, MCIB, the Specification referred to shall be understood to mean the latest revision of said specification as amended at the time of the Notice to Bidders, except as noted on the Drawings or in the Modifications to Detailed Specifications.

1.04. SUBMITTALS

The Contractor shall provide certifications or shop drawings on all materials provided under these specifications in accordance with the General Requirements. The Contractor shall submit the following:

- A. Prior to submittal of shop drawings, manufacturer shall approve proposed panel layout and proposed details. Contractor shall then submit shop drawings showing proposed panel layout to cover area to be lined. Show on shop drawings proposed details for installation of liner at seams, terminations, corners, openings, pipe penetrations, etc., and type of factory and field welds and attachments.
- B. Submit catalog of the manufacturer of plastic liner, including complete data indicating the physical properties and chemical resistance properties as required in this specification.
- C. Provide sufficient details to permit placement of liner without use of design Drawings. Reproduction of design Drawings for use as shop drawings will not be allowed. Do not begin fabrication of liner until after shop drawings and submitted materials have been reviewed and accepted by the Engineer.

1.05. REFERENCE STANDARDS

- A. ASTM D412 - Standard Test Methods for Vulcanized Rubber and Thermoplastic Rubber and Thermoplastic Elastomers-Tension

- B. ASTM D2240 - Standard Test Method for Rubber Property—Durometer Hardness

1.06. INSTALLER QUALIFICATIONS

- A. Applicators

- 1. Application of plastic liner to forms and other surfaces, liner finishing, repair, and testing is considered highly specialized work and shall be performed only by firms and individuals recommended and approved by lining manufacturer. Personnel performing such work shall be trained in methods of installation and demonstrate their ability to JCW.

- B. Welders

- 1. Each welder shall pass qualification welding test before doing welding. Requalification may be required at time deemed necessary by JCW. Provide at least 24 hours notice to JCW to schedule qualification welding test.
 - 2. Make test welds in presence of JCW. Test welds shall consist of following:
 - a. Begin with two pieces of liner, at least 15 inches long and 9 inches wide. Hold pieces in vertical position, lapped 1-1/2 inches.
 - b. Position weld strip over edge of lap and weld to both pieces of liner. Extend each end of weld strip at least 2 inches beyond liner to provide tabs.
 - 3. The weld specimen will be tested as follows:
 - a. Subject each weld strip tab, tested separately, to 10-pound pull normal to face of liner with liner secured firmly in place. Weld is acceptable when there is no separation between weld strip and liner.
 - b. Cut three test specimens from welded sample and tested in tension across welds. Tensile strength measured across welded joints shall be at least 2000 psi when tested in accordance with ASTM D412. When none of these specimens fails when tested as indicated above, weld will be considered satisfactory.
 - c. If one specimen fails to pass tension test, retest will be permitted. Retest shall consist of testing three additional specimens cut from original welded sample. When three retest specimens pass test, weld will be considered satisfactory.
 - 4. A disqualified welder may submit new weld sample when welder has had sufficient off-the-job training or experience to warrant re-examination.

PART 2 MATERIALS

2.01. MANUFACTURERS

Plastic liner shall be T-Lock as manufactured by Ameron Protective Linings Division; or approved equal.

2.02. MATERIALS

A. Manufacturing

1. Manufacture plastic liner sheet, joint, corner and weld strips from high molecular weight thermoplastic polymer compounded to make permanently flexible material suitable for use as protective liner in concrete pipe or other concrete structures. Polyvinyl chloride resin shall constitute not less than 99 percent by weight of resin used in formulation. Copolymer resins will not be permitted.
2. During manufacture or prior to final acceptance of Work, JCW may sample specimens taken from sheets, strips, or welded joints for testing.
3. Changes in formulation will be permitted only after prior notice is given to JCW and manufacturer demonstrates that new plastic liner will meet or exceed requirements for chemical resistance and physical properties.

B. Properties

1. Plastic liner sheets including locking extensions, joints, corners, and welding strips shall be free of cracks, cleavages or other defects adversely affecting protective characteristics of material.
2. Except at shop welds, plastic liner sheets, joint, corner, and weld strips shall have the following properties when tested at 77°F ± 5°F.

PROPERTY	ASTM TEST METHOD	CHEMICAL RESISTANCE TEST	
		INITIAL	AFTER CHEMICAL EXPOSURE (Note 1)
Tensile strength, min.	D 412, Die B	2200 psi	2100 psi
Elongation at break, min.	D 412, Die B	200%	200%
Shore durometer, Type D	D 2240, Within 1 sec.	50-60	+5 (Note 2)
Weight change	D 2240, 10 sec. (Note 3)	35-50	+5 (Note 2)
		-----	+1.5 % (Note 2)

Notes:

1. For 112 days in chemical solutions
2. With respect to initial test results
3. Specimen shall be 1-inch by 3-inch sample sheet thickness, taken from sheet or strip prior to final acceptance of work.

2.03. MATERIAL TESTS

- A. Material Properties: Test samples taken from sheets, joints or weld strips to determine material properties. Determine PVC tensile strength and elongation in accordance with ASTM D412 using Die B. Determine indentation hardness in accordance with ASTM D2240 using Type D durometer, except that single thickness of material will be used. Determination of change of weight and indentation hardness is shall be made of 1-inch by 3-inch specimens. Thickness of specimens shall be thickness of sheet or strip.
- B. Measurement of Initial Physical Properties: Determine initial values for tensile strength, weight, elongation and indentation hardness prior to chemical resistance tests.
- C. Chemical Resistance Tests

- 1. Determine physical properties of specimens after exposure to chemical solutions. Condition test specimens to constant weight at 110 degrees F before and after submersion in the following solutions for period of 112 days at 77° F plus or minus 5° F.

Chemical Solution Concentration

Sulfuric acid	20%*
Sodium hydroxide	5%
Ammonium hydroxide	5%*
Nitric acid	1%*
Ferric chloride	1 %
Soap	0.1 %
Detergent (linear alkyl benzyl sulfonate or LAS)	0.1%
Bacteriological BOD	not less than 700 ppm

* Volumetric percentages of concentrated C.P. grade reagents.

- 2. At 28-day intervals, remove specimens from each chemical solution and test. When specimen fails to meet 112-day property requirements specified in paragraph 2.02B before completion of 112-day exposure, material will be rejected.
- D. Pull Test for Locking Extensions: Liner locking extensions embedded in concrete shall withstand test pull of at least 100 pounds per linear inch, applied perpendicularly to concrete surface for period of 1 minute, without rupture of locking extensions or withdrawal from embedment. Perform this test at temperature between 70° F and 80° F, inclusive.
- E. Shop-Welded Joints: Shop-welded joints used to fuse individual sections of liner together, shall meet minimum requirements of liner for thickness, corrosion resistance and impermeability. Welds shall show no cracks or separations and be tested for tensile strength. Tensile strength, measured across welded joint in accordance with ASTM D412 using Die B, shall be at least 2000 psi. Test temperature is shall be 77° F ± 5° F and use measured minimum width and thickness of reduced test specimen section.
- F. Spark Test: Shop and field test liners for holidays or flaws using an approved spark tester set to provide minimum of 20,000 volts (Tinker and Razor Model AP-

W with power pack, or approved equal). Satisfactorily repair sheets having holes in shop prior to shipment from manufacturer's plant. Repairs shall be made by welders qualified in accordance with these specifications.

2.04. MATERIAL DETAILS AND DIMENSIONS

A. Approval of Details: Liner sheet, strip, and other accessory pieces shall conform to requirements of these Specifications.

B. Thickness of Material: Minimum thickness of PVC sheet and strip shall be as follows:

Material	Thickness in Inches
Sheet, integral locking extensions	0.065
Sheet, plain	0.094
Joint strip	0.094
Weld strip	0.125

C. Material Sizes: Use pipe-size sheets for sheets of PVC liner to provide coverage required by Drawings. Structural sheets shall be standard 48-inches by 96-inches, with special size noted on shop drawings. Lengths specified shall include tolerance at ratio of plus or minus 1/4-inch for each 100 inches, or 0.25 percent. Joint strips shall be 4 inches plus or minus 0.25 inch in width and have each edge beveled prior to application. Weld strips shall be 1 inch plus or minus 0.125 inch in width. Weld strips shall have edges beveled at time of manufacture.

D. Locking Extensions

1. No polygrip-type holding or locking extension will be permitted.
2. PVC liner to be embedded in concrete shall have integral locking extensions. Liner may not be bonded to concrete surfaces with adhesives except as specifically acceptable to JCW.
3. PVC locking extensions shall be the same material as the liner, shall be integrally molded or extruded with sheets, and shall have an approved cross section with minimum height of 0.375 inch and minimum web thickness of 0.085 inch. They shall be approximately 2.5 inches apart and be such that when extensions are embedded in concrete, liner will be held permanently in place.
4. PVC locking extensions shall be parallel and continuous except where interrupted for joint flaps, weep channels, strap channels and for other purposes shown on Drawings or permitted by JCW.
5. The liner sheet edge which will be lower terminal edge in structure is not to extend beyond base of final locking extension more than 0.375 inch.

E. Provisions for Strap Channels: Unless alternate methods are acceptable to JCW, liner required to be secured to inner form with straps shall have strap channels at not more than 20 inches on center perpendicular to locking extensions. Strap channels shall be a maximum of 1-inch wide and formed by removing locking extensions so that maximum of 3/16-inch remains. Channels shall not be

provided in final two locking extensions adjacent to terminal edge of liner coverage.

- F. Flaps: When transverse flaps are specified or required, fabricate by removing locking extensions so that no more than 1/32 inch of base of locking extensions remains on sheet.
- G. Adhesive Products: Adhesive products and application procedures used in installation of liner shall be according to manufacturer's recommendations. Adhesive products intended for use inside cast-in-place structures shall be non-flammable.
- H. Cleaners: Cleaners used in installation of liner shall be reviewed by JCW prior to use. Cleaners shall be nonflammable and water soluble or water dispersible and not be detrimental to plastic liner.
- I. Caulking Products: Caulking products and application procedures used in installation of liner and appurtenances shall be as recommended by manufacturer.
- J. Mechanical Anchors: When approved for use with plain sheet liner, provide anchors and washers of Type 316 stainless steel, and as recommended by liner manufacturer.

PART 3 EXECUTION

3.01. NOTIFICATION

For liners on cast-in-place structures, notify the Engineer and JCW at least 24 hours before reinforcing steel placement so that lining may be inspected and errors corrected.

3.02. PLACING LINER

- A. Location: Install liner at locations indicated by the Drawings.
 - 1. Reinforced Concrete Pipe: Install liner around the entire circumference of the inside of the pipe and on all exposed surfaces inside of manholes and structures.
 - 2. Precast Concrete Manholes: Install liner to cover all exposed concrete surfaces from the bottom of the manhole ring vertically to and including the bench and trough.
 - 3. Cast-In-Place Concrete Structures: Install liner through the cast-in-place concrete structure to cover all exposed concrete surfaces including the bench and trough. Liner shall be applied and secured to forms and inspected by the Engineer and JCW prior to placement of reinforcing steel.

B. Positioning Liner

1. Position PVC liner installed in pipe so that locking extensions are parallel to longitudinal axis of pipe.
2. Position PVC liner installed in cast-in-place structures so that locking extensions are parallel to direction of concrete placement, which is normally vertical for walls.
3. Closely fit liner to inner forms. Where possible, curved and warped surfaces shall be lined with full sheets of liner with cuts in or removal of the locking extensions. If cut sheets must be used, a minimum number of separate pieces shall be used.
4. If required on the Drawings, the Contractor shall use patterns or marking of sheet layouts directly on forms where complicated warped surfaces are involved.
5. At transverse joints between sheets of liner used in cast-in-place structures and pipe and manhole joints, space between ends of locking extensions, measured longitudinally, shall not exceed 4 inches. Where sheets are cut and joined for purpose of fitting irregular surfaces, this space shall not exceed 2 inches.

C. Securing Liner in Place

1. Liner shall be held snugly in place against inner forms. For pipes and similar circular sections, use light steel banding straps or other approved means. Prefabricated pipe-size tubular sheets which do not require strap channels may also be used.
2. When used, place banding straps in strap channels, as specified under provision for strap channels, at spacing not to exceed 20 inches.
3. Any method of banding, other than in strap channels, shall be reviewed by the Engineer and JCW prior to use.
4. On vertical surfaces where form ties or form stabilizing rods pass through liner, make provisions to maintain liner in close contact with forms during concrete placement. These provisions shall be reviewed by the Engineer and JCW.
5. Prevent concrete from flowing around edges of sheets at joints by sealing joint or seam with waterproof tape recommended by manufacturer.
6. Forms in contact with plastic liner need not be oiled.

- D. Weep Channels: Weep channels will only be allowed with JCW approval. When used, weep channels shall not be less than 2 inches nor greater than 4 inches in width.

E. Liner Returns

1. Install liner return where shown on approved shop drawings and wherever surfaces lined with plastic liner joins surfaces, which are not so lined.
2. Unless otherwise indicated by Drawings or approved shop drawings showing liner installation methods, make returns as follows:
 - a. Return liner at least 6 inches at surfaces of contact between concrete structure and items not concrete (including access frames, gate guides and pipe penetrations). If curvature of the manhole wall requires a longer pipe penetration through the wall-to-pipe gasket, increase the length of return liner to ensure no unlined exposed concrete surfaces inside of the manhole.
 - b. Follow the same procedure at joints where type of protective lining is changed, or new work is built to join existing unlined concrete.
3. Provide locking extensions on returns to lock returns to concrete of plastic-lined, cast-in-place structures.
4. Seal each liner return to adjacent construction with which it is in contact by means of an adhesive system recommended by manufacturer and acceptable to JCW. When joint space is too wide or joint surfaces too rough to permit use of compound, fill joint space with 2 inches of densely caulked cement mortar, lead wool, or other caulking material and finished with minimum of 1-inch depth of an approved corrosion resistant sealant material.

3.03. CONCRETING OPERATIONS

A. Concrete Placement

1. Carefully vibrate concrete placed against liner shall be so as to avoid damage to liner and to produce dense concrete securely anchoring locking extensions into concrete. Use external vibrators in addition to internal vibrators, particularly along lower terminal edge of liner.
2. Stiffeners, when used along locking extensions of liner installed in forms for pipe, shall be withdrawn completely during placement of concrete in forms. Re-vibrate concrete to consolidate concrete in void spaces caused by withdrawal of stiffeners.

B. Removing Forms

1. In removing forms, take care to protect liner from damage. Do not use sharp instruments to pry forms from lined surfaces. When forms are removed, pull nails that remain in liner plate without tearing liner and clearly mark resulting holes. Mark form tie holes before ties are broken off. Mark areas of abrasion of liner.

2. Following completion of form removal, clean liner in pipe and structures for inspection.
3. Remove banding straps used in securing liner to forms of cast-in-place structures within limits of unlined invert.

3.04. FIELD JOINTING OF LINER

A. Installation Requirements

1. No field joint shall be made in liner until 7 days have elapsed after the lined pipe, manhole, or structure has been backfilled and has been tested in accordance with the specifications herein. Where ground water is encountered, joint shall not be made until pumping of ground water has been discontinued for at least 7 days and no visible leakage is evident at joint. Liner at joints shall be free of mortar and other foreign material and be clean and dry before joints are made.
2. Hot joint compound shall not be brought in contact with liner.
3. No coating shall be applied over joint, corner or welding strip, except where nonskid coating is applied to liner surfaces.

B. Field Joints in Pipe Installation

1. Field joints in lining at pipe joints and precast manhole joints shall be one of the following types:
 - a. Type P-1 (JCW approval required): Make joint with separate 4-inch joint strip and two welding strips. Center 4-inch joint strip over joint, heat-sealed to lining, then welded along each edge to adjacent liner sheets with 1-inch weld strip. 4-inch joint strip shall lap over each sheet minimum of 2 inch.
 - b. Type P-2
 - i. Make joint with joint flap with locking extensions removed as described in paragraph 2.04 above, and extending approximately 4 inches beyond pipe end. Joint flap shall overlap lining in adjacent pipe section minimum of 2 inch and be heat-sealed in place prior to welding. Complete field joint by welding flap to lining of adjacent pipe using 1-inch weld strip.
 - ii. Take care to protect flap from damage. Avoid excessive tension and distortion in bending back flap to expose pipe joint during laying. At temperatures below 50° F heating of liner may be required to avoid damage.
2. Joints between lined pipe and lined structures shall be either Type C-1 joint or Type C-2 joint as described below.

- C. Field Joints in Concrete Structures: Field joints in liner on concrete structures shall be one of following types:
1. Type C-1. Make joint with separate 4-inch joint strip and two welding strips. Center 4-inch joint strip over joint, heat-sealed to liner, then welded along each edge to adjacent sheets with 1-inch wide weld strip. Width of space between adjacent sheets is not to exceed 2 inches. 4-inch joint strip shall lap over each sheet minimum of 2 inch. It may be used at transverse or longitudinal joint.
 2. Type C-2. Make joint by lapping sheets not less than 2 inch. One 1-inch weld strip is required. Upstream sheet shall overlap one downstream. Heat-seal lap into place prior to welding on 1-inch weld strip.
 3. Type C-3. Make joint by applying 2-inch wide waterproof tape or 1-inch wide welding strip on back of maximum 1/4-inch gap butt joint or by some other method approved by JCW to prevent wet concrete from getting under sheet. After forms have been stripped, apply 1-inch weld strip over face to sheet.
- D. Installation of Welding Strips
1. All welding of joints shall be in strict conformance with specifications and instructions of lining manufacturer.
 2. Welding shall fuse both sheets and weld strip together to provide continuous joint equal in corrosion resistance and impermeability to liner plate.
 3. Hot-air welding tools shall provide effluent air to sheets to be joined at temperature between 500° F and 600° F. Hold welding tools approximately 2 inches from and moved back and forth over junction of two materials to be joined. Move welding tool slowly enough as weld progresses to cause small bead of molten material to be visible along both edges and in front of weld strip.
 4. Maintain adequate ventilation in confined spaces during welding operations.
 5. After repairs have been made, defective welds will be re-inspected and re-tested.
- E. Application of Liner to Concrete Surfaces with Adhesives: Application of liner plate to concrete surfaces by means of adhesive is allowed only where shown on Drawings for existing structures, or where specifically acceptable to JCW and called out on approved shop drawings, and shall be accomplished by following steps:
1. Etch concrete surface by abrasive blasting to develop slightly granular surface.
 2. After abrasive blasting, thoroughly clean concrete surface of dust.

3. Apply primer, adhesive and liner in strict accordance with manufacturer's recommendations, as approved by JCW.
 4. Place mechanical anchors at 12-inch centers each way after adherence of liner to concrete surface has been achieved. Place anchors after adhesive system has cured for minimum of 24 hours. Seal penetration of liner by anchor in accordance with manufacturer's recommendations.
- F. Nonskid Surfaces: Horizontal surfaces at the bottom of structures or manholes, such as the bench, and other surfaces of liner, shown on Drawings to be nonskid, shall be treated as follows prior to installation:
1. Liner shall be cleaned, dried, and spread with an adhesive coating recommended by manufacturer of liner plate.
 2. Liberally sprinkle surface with clean, dry, well graded sand, which will pass No. 30 sieve but be retained on No. 70 sieve.
 3. After sanded surface has thoroughly dried, brush away excess sand and spray seal coat of adhesive coating over sand in sufficient quantity to coat and bond sand to liner plate.
 4. Allow coated sand surface to dry thoroughly before handling.
- G. Protection and Repair of Liner
1. Take necessary measures and precautions to prevent damage to liner from equipment and materials used in or taken through Work. Repair damage to installed liner plate in accordance with requirements for repair of liner and with JCW approval.
 2. Patch nail and tie holes and cut, torn and seriously abraded areas in liner plate. Patches made entirely with welding strip shall be fused to liner over entire patch. Use of this method is limited to patches, which can be made with single welding strip. Use of parallel, overlapping or adjoining welding strips will not be permitted. Larger patches may consist of smooth liner over damaged area, with edges covered with welding strips fused to patch and to liner adjoining damaged area. Limit size of single patch of latter type only as to its width, which shall not exceed 4 inches.
 3. Whenever liner is not properly anchored to concrete, or whenever patches larger than those permitted above are necessary, accomplish repair of liner and restoration of anchorage by injecting epoxy grout behind liner plate by method approved by JCW. Use of adhesives will not be allowed to repair improperly anchored liner plate.
- H. Field Tests
1. Upon completion of installation, clean surface of liner to permit visual inspection and spark testing. Contractor shall perform spark test in the presence of Engineer and/or JCW, using spark-type detector complying

with requirements for Spark Test. Contractor shall properly repair and retest areas of liner failing to meet field test.

2. During inspection and spark testing, Contractor shall provide adequate ventilation, ladders for access, barricades or other traffic control devices, and is responsible for opening and closing entrances and exits.
3. Spark testing of liner by Contractor shall be done with detector complying with these Specifications.

END OF SECTION 6650